

**MULTI-LOOP MODULE TYPE
TEMPERATURE CONTROLLER
<Control Module>**

TYPE: PUMA/B

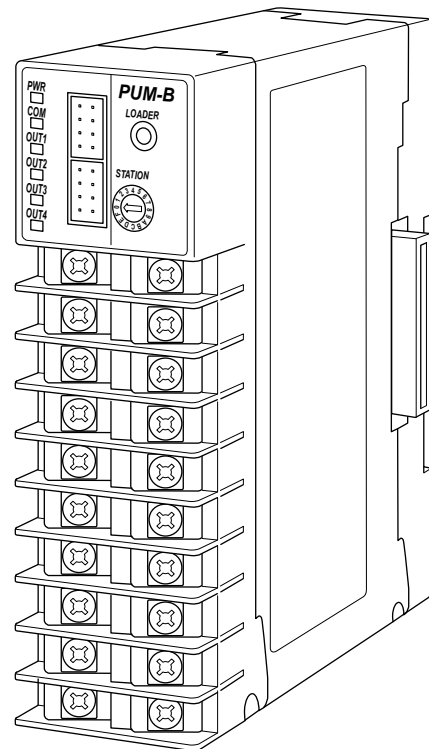
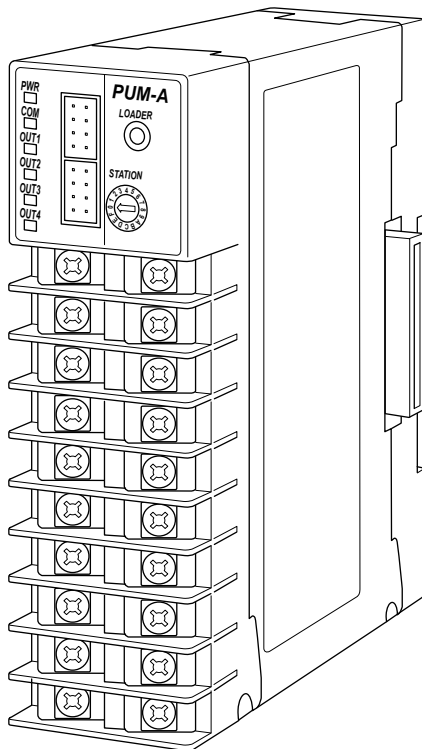

Please Read First (Safety Warnings)

Please read this section thoroughly before using and observe the mentioned safety warnings fully.

Safety warnings are categorized as “Warning” or “Caution”.

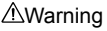
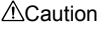
 Warning	Improper use of the equipment may result in death or serious injuries.
 Caution	Improper use of the equipment may cause injury to the user or property damage.

Warning

Installation and Wiring

- This equipment is intended to be used under the following conditions.

Ambient temperature	-10 to 50 degree C
Ambient humidity	90% RH or below (with no condensation)
Vibration	10 to 70Hz less than 9.8m/s ² (1G)
Warm-up time	30 min. or more
Installation category	IEC1010-1: class II
Pollution level	IEC1010-1: degree 2

- Between the temperature sensor and the location where the voltage reaches or generates the values described below, secure clearance space and creepage distance as shown in the table below.



If such space cannot be secured, the EN61010 safety compliance may become invalid.

Voltage used or generated by any assemblies	Clearance Space [mm]	Creepage Space [mm]
Up to 50 Vrms or Vdc	0.2	1.2
Up to 100 Vrms or Vdc	0.2	1.4
Up to 150 Vrms or Vdc	0.5	1.6
Up to 300 Vrms or Vdc	1.5	3.0
Above 300 Vrms or Vdc	Please consult our distributor	

- For the above, if voltage exceeds 50Vdc (called danger voltage), basic insulation is required between the earth and all terminals of the equipment.

Note that the insulation class for this equipment is as follows. Before installing, please confirm that the insulation class for equipment meets usage requirements.

Power	PV1 Input
Loader communication port	PV2 Input
RS-485 communication port	PV3 Input
CT Input (CT1A, B - CT4A,B)	PV4 Input
OUT1 (relay contact output)	OUT1 (SSR drive, current)
OUT2 (relay contact output)	OUT2 (SSR drive, current)
OUT3 (relay contact output)	OUT3 (SSR drive, current)
OUT4 (relay contact output)	OUT4 (SSR drive, current)

 Basic insulation (1500Vac)
 Functional insulation (1000Vac)
 Functional insulation (500Vac)

- In cases where damage or problems with this equipment may lead to serious accidents, install appropriate external protective circuits.
- To prevent damage and failure of the equipment, provide the rated power voltage.
- To prevent electric shock and equipment failure, do not turn the power ON until all wiring is complete.
- Before turning the power ON, confirm that clearance space has been secured to prevent shock or fire.
- Do not touch the terminal while the machine is ON. Doing so risks shock or equipment errors.
- Never disassemble, convert, modify or repair this equipment. Doing so risks abnormal operation, shock or fire.

Maintenance

- When installing or removing the equipment, turn the power OFF. Otherwise, shock, operational errors or failures may be caused.
- Periodic maintenance is recommended for continuous and safe use of this equipment.
- Some parts installed on this equipment have a limited life and/or may deteriorate with age.
- The warranty period for this unit (including accessories) is one year, if the product is used properly.

Caution

Cautions when Installing

Please avoid installing in the following locations.

- Locations in which the ambient temperature falls outside the range of 0 to 50 degrees C when equipment is in use.
- Locations in which the ambient humidity falls outside the range of 45 to 85% RH when equipment is in use.
- Locations with rapid temperature changes, leading to dew condensation.
- Locations with corrosive gases (especially sulfide gas, ammonia, etc.) or flammable gases.
- Locations with vibration or shock directly.

- Locations in contact with water, oil, chemicals, steam or hot water.
(If the equipment gets wet, there is a risk of electric shock or fire, so have it inspected by Fuji distributor.)
- Locations with high concentrations of atmospheric dust, salt or iron particles.
- Locations with large inductive interference, resulting in static electricity, magnetic fields or noise.
- Locations in direct sunlight.
- Locations that build up heat from radiant heat sources, etc.

Cautions when Mounting to Cabinets / DIN Rails

- In case of mounting the temperature controllers to DIN rails, remember to push up the locking tabs to fasten the controllers onto DIN rail.
- To connect controllers, first release all locking tabs. Then, connect controllers and push up all locking tabs. Make sure that all locking tabs are fastened.
- Never fail to turn the power OFF, before detaching the terminal block or removing the main unit from the base part.
- In order to aid heat dissipation, do not block the top and the bottom of the equipment.
- When mounting / dismantling controllers to / from DIN rails, 30mm of clearance above and under the controllers should be provided.

Cautions for Wiring

- For thermocouple input, use the designated compensation lead. For resistance bulb input, use wires with small lead wire resistance and without any resistance difference among three wires.
- Input signal wire and output signal wire should be separated from each other. And both should be shielded.
- If the output operation frequency is high, selecting a SSR/SSC drive output type is recommended.

[Proportionate cycles]

Relay output:	30 sec. or more
SSR/SSC drive output:	1 sec. or more

- When inductive loads such as magnetic opening/closing equipment, etc. as relay output equipment are connected, use of "Z-trap," manufactured by Fuji Electric Device Technology Co., Ltd., is recommended in order to protect the contacts against opening/closing surges and to ensure long-term use.

Model names: ENE241D-07A
(For 100V power voltage)
ENE471D-07A
(For 200V power voltage)

Attachment position:

Please connect between the relay control output contacts.

(Example)

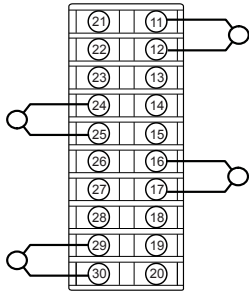

Z-trap connecting diagram

- To comply with CE marking (EMC), we recommend to attach ferrite core to communication cable and power cable.
- For wiring to the terminal block, apply crimp type terminals size M3.
Use terminal screws in this product only.
Screw size: M3×7 (with square washer)
Screw tightening torque: 0.78N·m (8kgf·cm)
- To avoid the influence of inductive noise, input signal wires should be separated from electric power lines or load lines.

Error Operation

- The alarm function does not work properly when an error occurs unless the settings are made correctly. Always verify its setting before operation.
- In case of error input, PWR LED will flash. When replacing the sensor, make sure to turn the power OFF.

Others

- Please do not wipe the equipment with organic solvents such as alcohol or benzene, etc. If wiping is necessary, use a neutral cleaning agent.
- Do not use mobile phones near this equipment (within 50cm). Otherwise a malfunction may result.
- Malfunctions may occur if the equipment is used near a radio, TV, or wireless device.
- This equipment requires approx. 20 seconds before it starts to output.
- Before installing and wiring, take necessary measures for electrostatic discharge (ESD).
- The power supply for this product is 24V DC. Please use the power source of appropriate volume depending on the number of units you connect.

Recommended power supply :

Cosel Electronics Co., Ltd. PBA Series

Omron Corporation S8VM Series

Contents

Please Read First (Safety Warnings)	3	Multi-channel, Master/Slave System.....	3-5
△Warning	3	System Configuration Using Enhanced	
Installation and Wiring	3	Communication Module	3-6
Maintenance	3	Setting on RS-485 Host Communication	
△Caution	3	Equipment	3-7
Cautions when Installing	3	Trial Run	3-7
Cautions when Mounting to Cabinets/DIN Rails	4	3.2 Dimensions	3-8
Cautions for Wiring	4	Dimensions	3-8
Error Operation	4	3.3 Mounting Controllers	3-9
Others.....	5	How to Remove Front Terminal Block / Base	
1 Overview	1-1	Part from the Main Unit	3-9
1.1 Overview	1-3	Mounting to DIN Rails	3-11
1.2 Model Code	1-4	Order of Controllers	3-13
Control Module (4 channels)	1-4	3.4 Attaching Accessories (Optional)	3-14
Control Module (2 channels)	1-4	Attaching Side Connecting Terminal	
Accessories	1-5	Covers	3-14
1.3 Part Names and Functions	1-6	Attaching End Plates	3-14
External View	1-6	3.5 Mounting with Screws	3-15
Front Terminal Block	1-7	3.6 Terminal Block Diagram	3-16
Base Part	1-9	Wiring	3-16
2 System Configuration Example.....	2-1	Wiring for Power Supply / RS-485.....	3-17
2.1 System Configuration Example	2-3	Wiring for Heater Break Detection CT	3-18
Stand Alone	2-3	4 System Setting	4-1
Multi-channel, Stand Alone System	2-4	4.1 Operating Method	4-3
Multi-channel, Master/Slave System.....	2-5	Operating Method	4-3
System Configuration Using Analog		SV Value Setting	4-4
Input/Output Module Controllers	2-6	MV Value Setting	4-5
System Configuration Using Event		Running Auto-tuning	4-6
Input/Output Module Controllers	2-7	Auto/Manual Switch	4-8
System Configuration Using Enhanced		RUN/Standby Switch	4-9
Communication Module	2-9	Remote/Local Switch	4-10
3 Installation	3-1	Digital Output Latch Release	4-11
3.1 Installation Procedure	3-3	4.2 Input Setting	4-13
Stand Alone System	3-3	Input Setting	4-13
Multi-channel, Stand Alone System	3-4	PV Input Basic Setting.....	4-15
		PV Input Filter Setting	4-18
		PV Input Shift Setting	4-19

PV Display Zero & Span Adjustment Setting	4-20	SV Alarm	4-71
Cold Junction Compensation Setting	4-21	MV Alarm	4-72
Remote SV Input Source Setting	4-22	Interchannel Deviation Alarm	4-73
Remote SV Zero and Span Adjustment	4-23	Loop Break Alarm	4-75
4.3 Output Setting	4-25	HB (Heater Break) Alarm	4-77
Output Setting	4-25	Load Short-circuit Alarm	4-80
Output Proportional Cycle Setting	4-26	4.6 Communication Setting	4-83
Current Output Range Setting	4-27	Communication Setting	4-83
Output Source Setting	4-28	RS-485 Communication Speed Setting and	
Output Scaling Base and Span Setting	4-31	RS-485 Parity Setting	4-83
Output Shutdown Setting	4-32	RS-485 Communication Permission Setting	
4.4 Control Setting	4-33	4-84
Control Setting	4-33	Enhanced Communication Module (PUMC)	
Control Algorithm Select	4-34	Connection Permission	4-84
Proportional Band (P), Integration Time (I),		Master/Slave Setting in Connected Modules	
Derivative Time (D) Setting	4-37	4-85
Anti-reset Windup Setting	4-39	RS-485 Response Interval Time Setting	4-86
ON/OFF Control Hysteresis Setting	4-40	4.7 Optional Functions Setting	4-87
ON/OFF Hysteresis Setting	4-41	Optional Functions Setting	4-87
Direct/Reverse Action Setting	4-42	Digital Input Function Setting	4-88
Cooling Proportional Band Coefficient Setting		Linkage Operation Setting	4-92
.....	4-43	Input/Output Monitor Setting	4-96
Dead Band Setting	4-44	LED Display Setting	4-103
Output Convergence Value Setting	4-45	User Address Specification Communication	
SV Lower and Upper Limits Settings	4-46	4-106
SV Offset	4-47	Reset Main Unit	4-107
Ramp SV Settings	4-48	5 Communication	5-1
Control Output Limiter Type Setting	4-49	5.1 Communication Functions	5-3
Standby MV Setting	4-51	Connecting to a Programmable Controller	5-4
Soft Start Setting	4-52	Connecting to a Personal Computer	5-4
Operation Setting When Input Error Occured		5.2 Communication Specifications	5-5
.....	4-53	RS-485	5-5
Start up Mode Setting	4-54	Loader Interface	5-6
4.5 Event Output Setting	4-55	5.3 Connection	5-7
Event Output	4-55	Assignment of Communication Terminals	5-7
DO Event Types	4-57	Connection with RS-485	5-8
ALM Set Value1 / ALM Set Value2	4-62	Connection with Loader Interface	5-9
Operation Before and After Events		5.4 Setting Communication Parameters	5-10
Output Setting	4-64	Setup Items for RS-485 (PUM side)	5-10
DO Option Functions	4-68	Setup Items on Loader Interface	
Digital Output Latch Release	4-70	(PUM side).....	5-11

5.5 Modbus RTU Communication Protocol	5-12
Message Composition	5-14
Calculating Error Check Code (CRC-16)	5-17
Transmission Control Steps	5-18
5.6 Command and Transmission Frame Details	5-20
Reading Data	5-20
Writing Data	5-25
5.7 Address Map and Data Format	5-29
Operation Parameters	5-29
Control (PID) Parameters	5-30
Setup Parameters	5-31
System Parameters	5-32
Alarm Parameter	5-36
Communication Parameters	5-37
Configuration Parameters	5-40
Monitor Parameters	5-40
Order of Register Numbers	5-42
5.8 Sample Program	5-51

6 Troubleshooting **6-1**

6.1 Troubleshooting Procedures	6-3
Troubles that May Occur when the Loader	
Software is Connected	6-3
Troubles during Operation	6-4
Troubles with RS-485 Communication	6-7

Index

1

Overview

1.1	Overview	1-3
1.2	Model Code	1-4
1.3	Part Names and Functions	1-6

1.1 Overview

PUMA/B is a control module, which monitors and controls temperature.

PUMA:	Model with 4 control channels
PUMB:	Model with 2 control channels

- PUMA/B functions as the core of temperature control system made up of module type temperature controller PUM series.
- The type of input signal can be selected from thermocouple/resistance bulb and voltage/current.
- Temperature control is done by four types of control actions; 2 position control, PID control, Fuzzy PID control, and PID 2 control. PUMA/B is equipped with 2 points of CT terminals per channel in order to monitor heater break or short-circuit and can detect three phase heater break.
- Space and labor saving wiring ; with only one unit directly connected to power supply and RS-485, all connected controllers are also connected to them internally via side connectors.

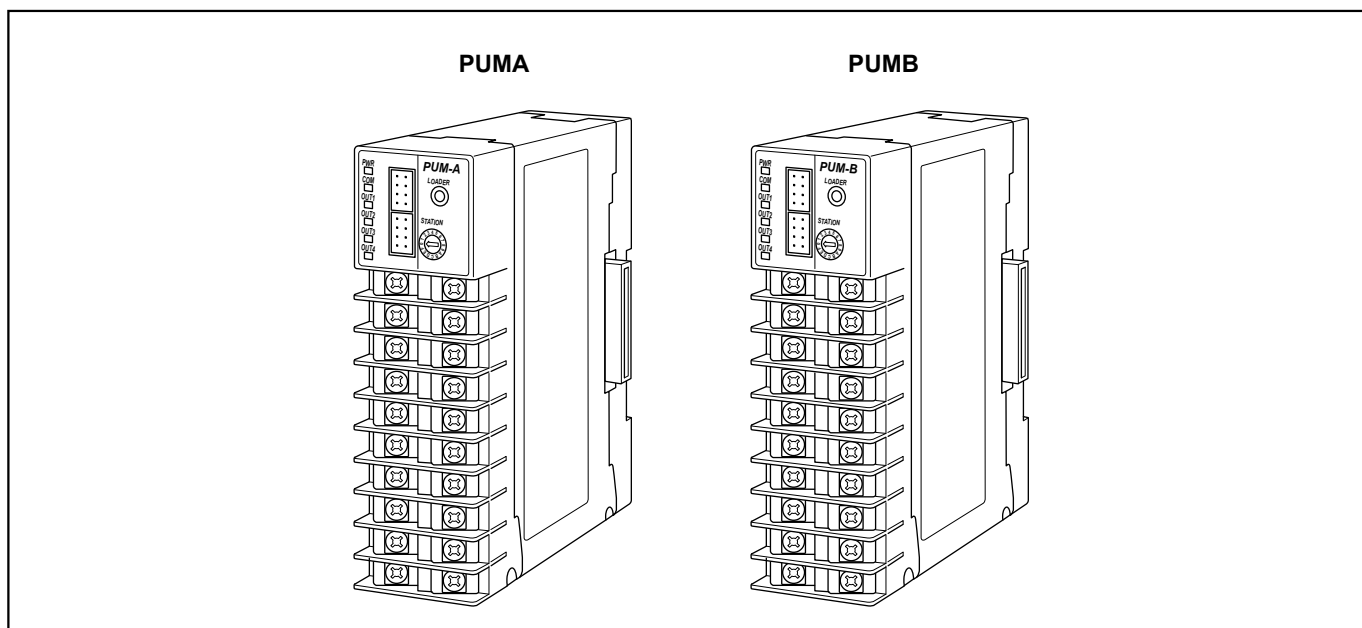

Hereinafter, PUMA/B will be referred to as “this equipment” or “control module”.

Confirming accessories

Before using the product, please confirm that all of following accessories are included.

Description	Quantity
Temperature Controller Control Module	1 unit
Instruction manual (Installation)	1 copy
I/V unit (250 ohm resistance)	1 unit per voltage/current input

1.2 Model Code

Control Module (4 channels)

1	2	3	4	5	6	7	8	9	10	11	12	13	Description
P	U	M						0			0	0	Module type
			A										4ch control module
				T									Input type
				A									Thermocouple / resistance bulb (all channels)
				C									Voltage / current (all channels)
													Thermocouple / resistance bulb (ch 1,2), voltage / current (ch3,4)
													OUT1,2 output type
					A								Relay output
					C								SSR drive output
					E								Current output
													OUT3,4 output type
					A								Relay output
					C								SSR drive output
					E								Current output
													Instruction manual
								A					Japanese
								B					English
													Option 1
									Y				Not fitted
									C				CT input (8 points)

Control Module (2 channels)

1	2	3	4	5	6	7	8	9	10	11	12	13	Description
P	U	M						0			0	0	Module type
			B										2ch control module
				T									Input type
				A									Thermocouple / resistance bulb (all channels)
													Voltage / current (all channels)
													OUT1, 2 output type
					A								Relay output
					C								SSR drive output
					E								Current output
													OUT3, 4 output type
					Y								Not fitted
					A								Relay output
					C								SSR drive output
					E								Current output
													Instruction manual
								A					Japanese
								B					English
													Option 1
									Y				Not fitted
									C				CT input (4 points)

Accessories

1	2	3	4	5	6	7	8	Description
P	U	M	Z	*				
A	0	1						RS-485 terminating resistance
A	0	2						DIN rail mounting end plate
A	0	3						Side connecting terminal cover (right & left 1 set)
A	0	4						Front face screw terminal cover
L	0	1						Loader connecting cable (RS-232C)
C	0	1						CT input terminal cable (for 4 points) (l=1m)
C	0	3						CT input terminal cable (for 4 points) (l=3m)
C	0	5						CT input terminal cable (for 4 points) (l=5m)
C	T	1						CT for 1 to 30A (CTL-6-S-H)
C	T	2						CT for 2 to 50A (CTL-12-S36-8)

1.3 Part Names and Functions

External View

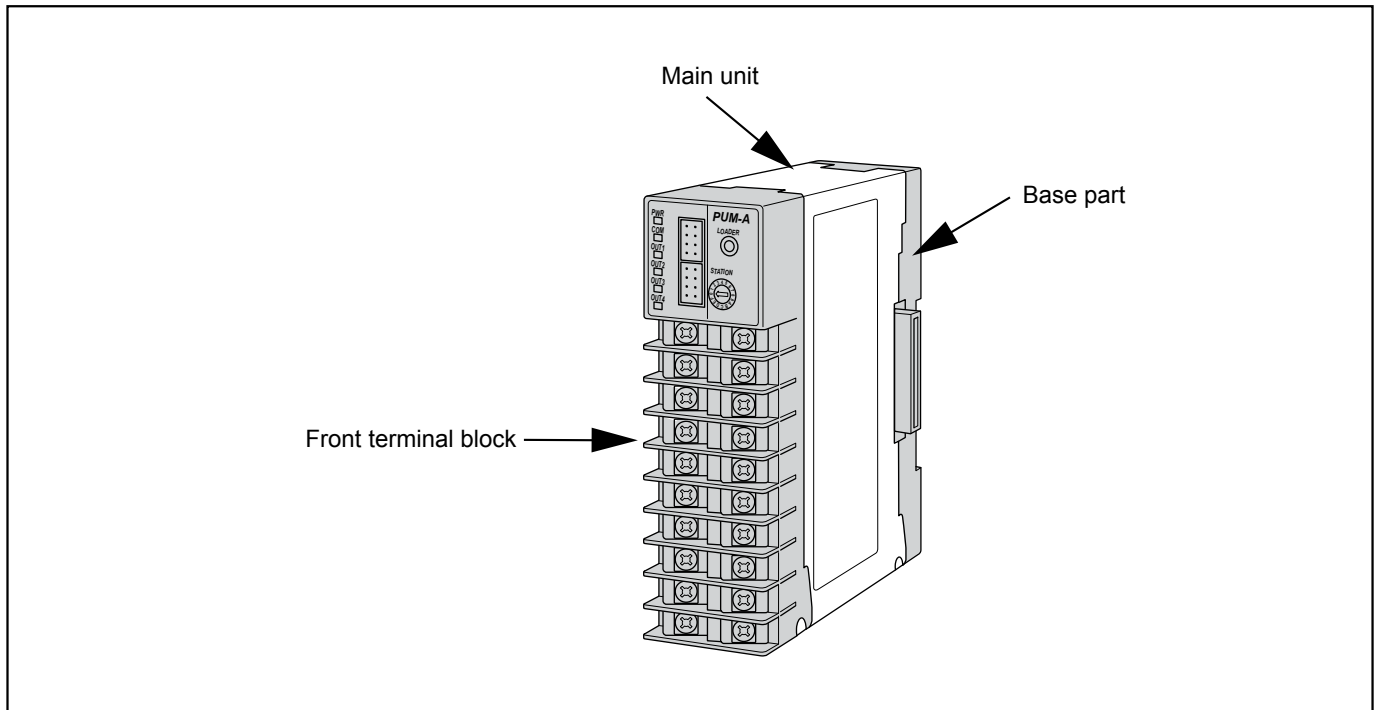

Front terminal block

The front terminal block is equipped with loader communication port, station No. configuration switch, and LED indicator lamps.

- Equipped with CT connector
- Removable from the main body without tools in seconds.

Main unit

The main unit of the controller

The main unit can be removed from the base part without tools in seconds.

Base part

The base part incorporates power terminal, RS-485 terminal and lateral connection connectors with a DIN-rail mounting structure.

Front Terminal Block

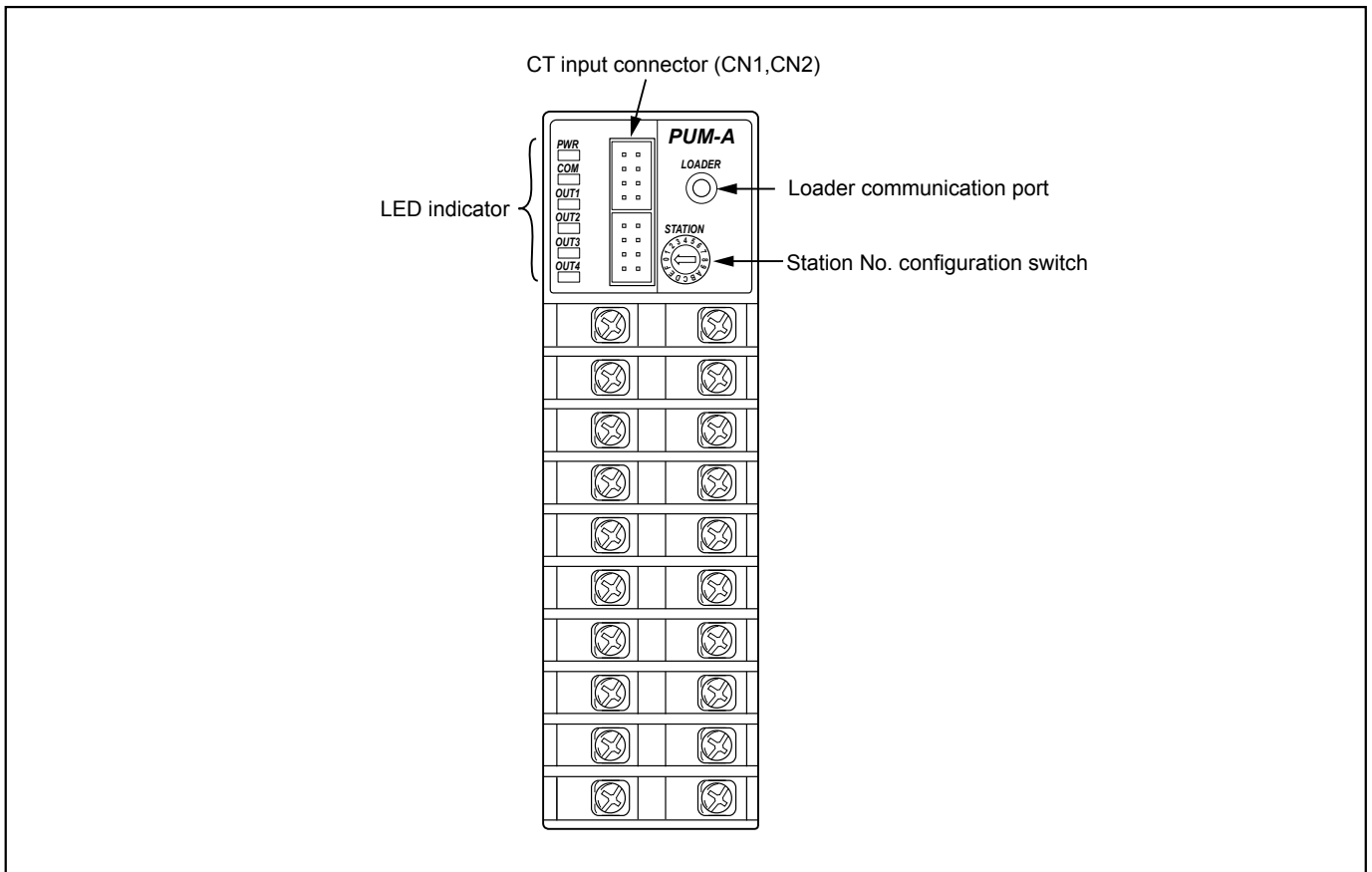

LED indicator

LED lamps indicate the following operational conditions.

LED	LED Status	Color	Operational condition
PWR	Illuminated	green	Normal operation (Slave station of internal communication)
	Blinking	green	Normal operation (Master station of internal communication)
	Illuminated	red	System fault (A/D converter error, internal communication error)
	Blinking	red	Input error
COM	Illuminated	green	RS-485 receiving
	Illuminated	orange	RS-485 transmitting
OUT1 to OUT4	Illuminated	green	Corresponding channel outputting
	Illuminated	red	Corresponding channel input error

*Actions to be displayed for COM and OUT1 to 4 can be allocated by programming.

CT input connector

CT input connector can be connected to a CT for current detection using an optional CT input terminal cable. CT input cable is required for both CN1 and CN2 separately. CN1 is used for channel 1 and 2, and CN2 for channel 3 and 4. Each channel has 2 points ([A] and [B]) of CT input terminals. Please note that CN2 is not available for 2 channel model type (PUMB).

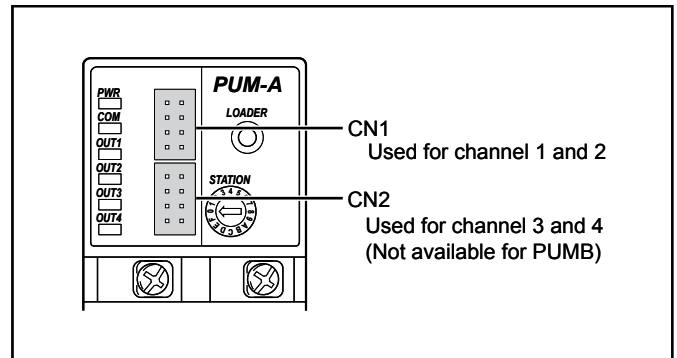

Loader communication port

Loader communication port is an interface to connect PUM with a PC with parameter loader software installed using an optional loader connecting cable.

Station No. configuration switch

Station No. configuration switch sets the station number of each controller. Apply a fine tip flat-head screwdriver to turn the Station No. configuration switch. Each of connected controllers must have a different Station number from other controllers. Duplicate station numbers may cause malfunction of the equipment.

SW setting	Station No.
0	1
1	2
2	3
3	4
4	5
5	6
6	7
7	8
8	9
9	10
A	11
B	12
C	13
D	14
E	15
F	16

Base Part

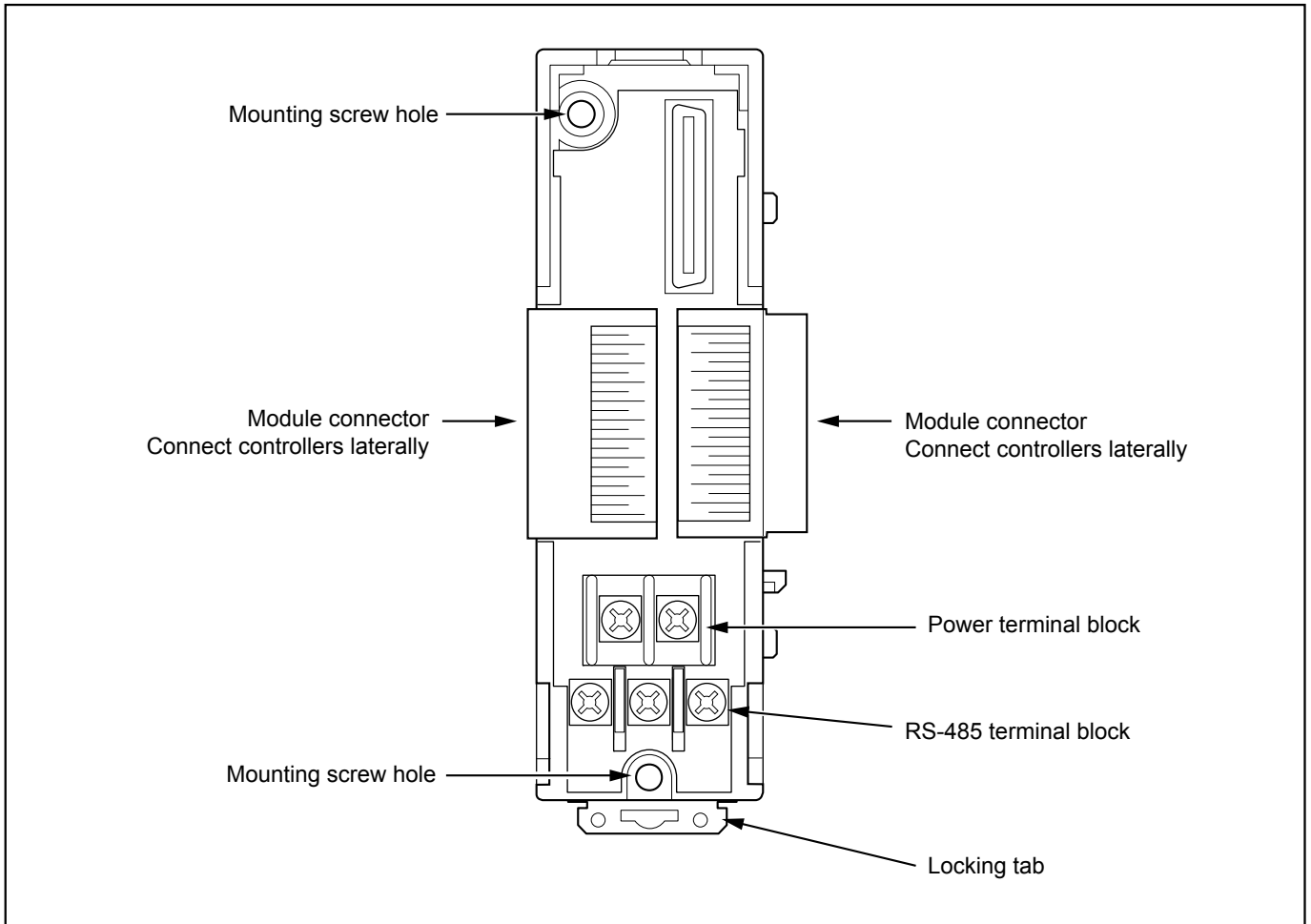

Module connector

Module connectors connect controllers laterally.

Power terminal block

Power terminal block connects power supply to PUMA/B.

If any one of connected controllers is directly connected with power supply, power will be provided to all of controllers via side connectors.

RS-485 terminal block

RS-485 terminal block connects an RS-485 communication cable to perform serial communication with PLC, operation display, and PC, etc.

If any one of connected controllers is directly connected with RS-485, all of controllers will be also connected via side connectors.

Locking tab

Locking tab fastens a controller onto DIN rail when mounting controllers to a DIN rail. Locking tabs also fasten controllers onto each other.

2

System Configuration Example

2.1 System Configuration Example ... 2-3

2.1 System Configuration Example

The followings are examples of a temperature controller system of multi-loop module type temperature controller PUM series.

Stand Alone

- This is the minimum configuration consisting of one control module controller only.
- Temperature control is performed at maximum 4 channels.
- Heater break and short circuit can be monitored using CT terminal.
- Configuration and operation can be done via PUM parameter loader software connected with loader communication port. Configuration and operation are performed using PC, PLC, and Operation display connected by RS-485 communication.

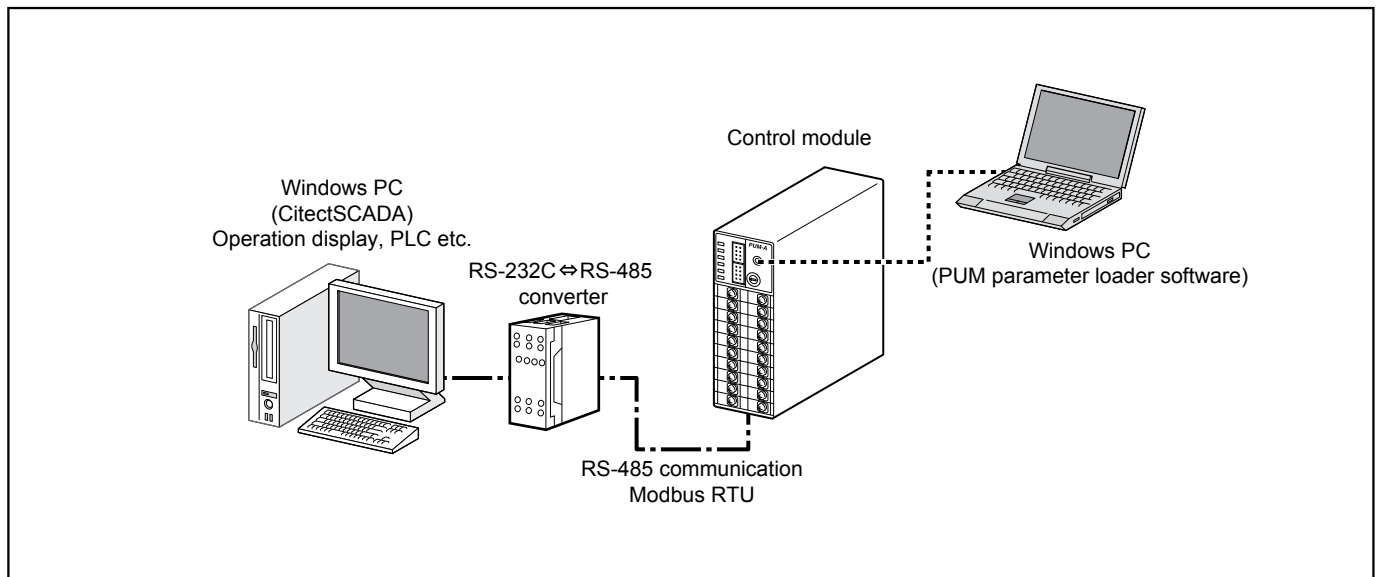

Basic setting items

In case of this example, the following settings are required.

- RS-485 communication setting

▶▶ 4-83

Multi-channel, Stand Alone System

- When more channels are required for temperature control, maximum 64 channels are available by connecting up to 16 units of control module.
- RS-485 and power supply can be shared among all connected controllers if one of connected controllers is directly connected to them, which saves time, labor and space for wiring.
- To configure controllers via loader communication port, connect all controllers one by one with a loader connecting cable and configure each controller separately.

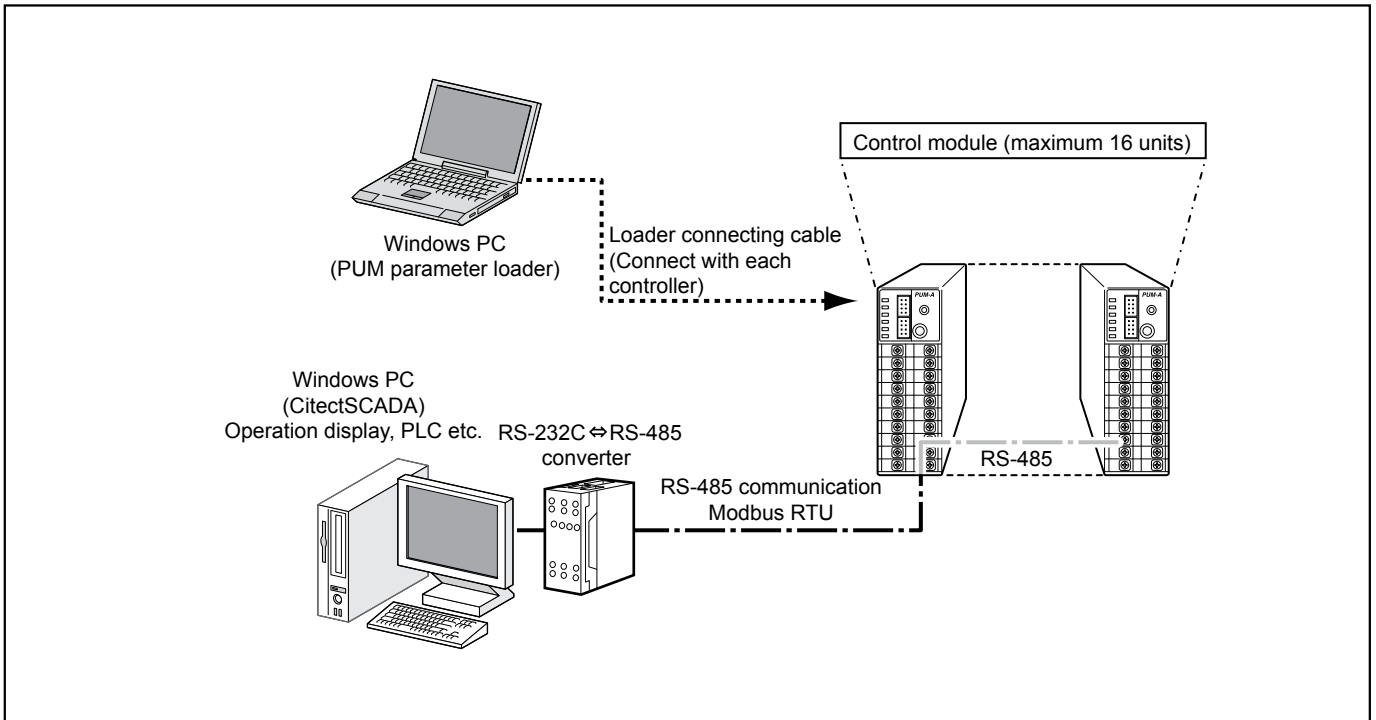

Basic setting items

In case of this example, the following settings are required.

- Station number setting
- RS-485 communication setting

Point

- Station number of control module controller (1 to 16)

In order to perform communication correctly, setting station number is required. Set the leftmost controller to "1". Number the rest of controllers consecutively as "2", "3", "16". Make sure that there is no duplicate station number in the same system.

Multi-channel, Master/Slave System

- Maximum 64 channels are available by connecting up to 16 units of control module.
- RS-485 and power supply can be shared among all connected controllers if the leftmost master controller is directly connected to them, which saves time, labor and space for wiring.
- Distribution, linkage operation, and Remote SV functions can be used by setting each controller as master or slave.
- In this configuration, all connected controllers can be configured by connecting the leftmost master controller with a loader connecting cable.

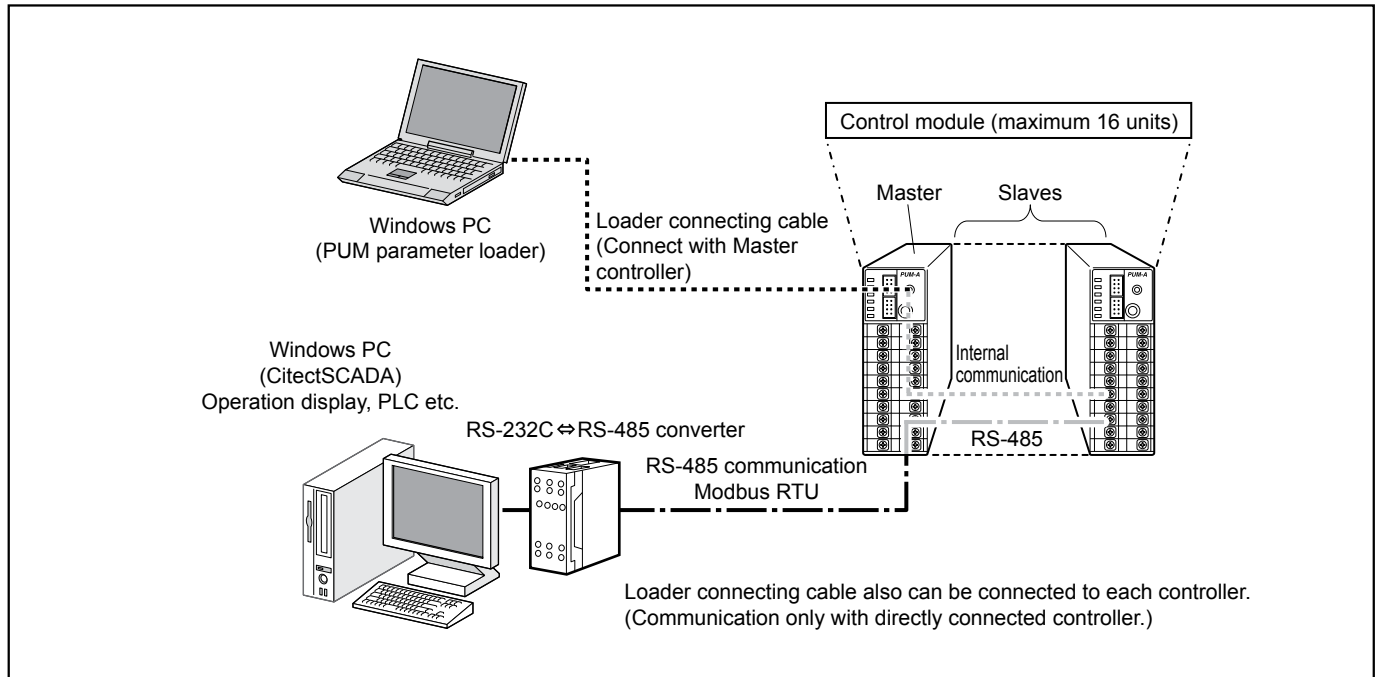

Basic setting items

In case of this example, the following settings are required.

- Station number setting
- Master/slave setting
- RS-485 communication setting

Point

- Master/slave setting
Set the leftmost unit of connected controllers as "Master" and the rest of them as "Slave". Each controller needs to be set as "Master" or "Slave" via a loader communication port only one. When connecting parameter loader software via loader communication port, it is only necessary to connect it with the master controller and all of slave controllers can be also configured. (If a slave controller is directly connected, the setting for other controllers cannot be done.)
PWR indicator lamp shows whether the unit is "Master" or "Slave".

PWR indicator	Action
Master controller	Green lamp will blink at startup and during operation.
Slave controller	Green lamp will be illuminated at startup and during operation.

System Configuration Using Analog Input/Output Module Controllers

- By adding analog input/output module to the system, re-transmission output and remote SV functions can be used as extended input/output of control module. They can be also used as analog input/output from the host equipment.
- Total maximum 16 units (64 channels) of control module and analog input/output module controllers can be connected.

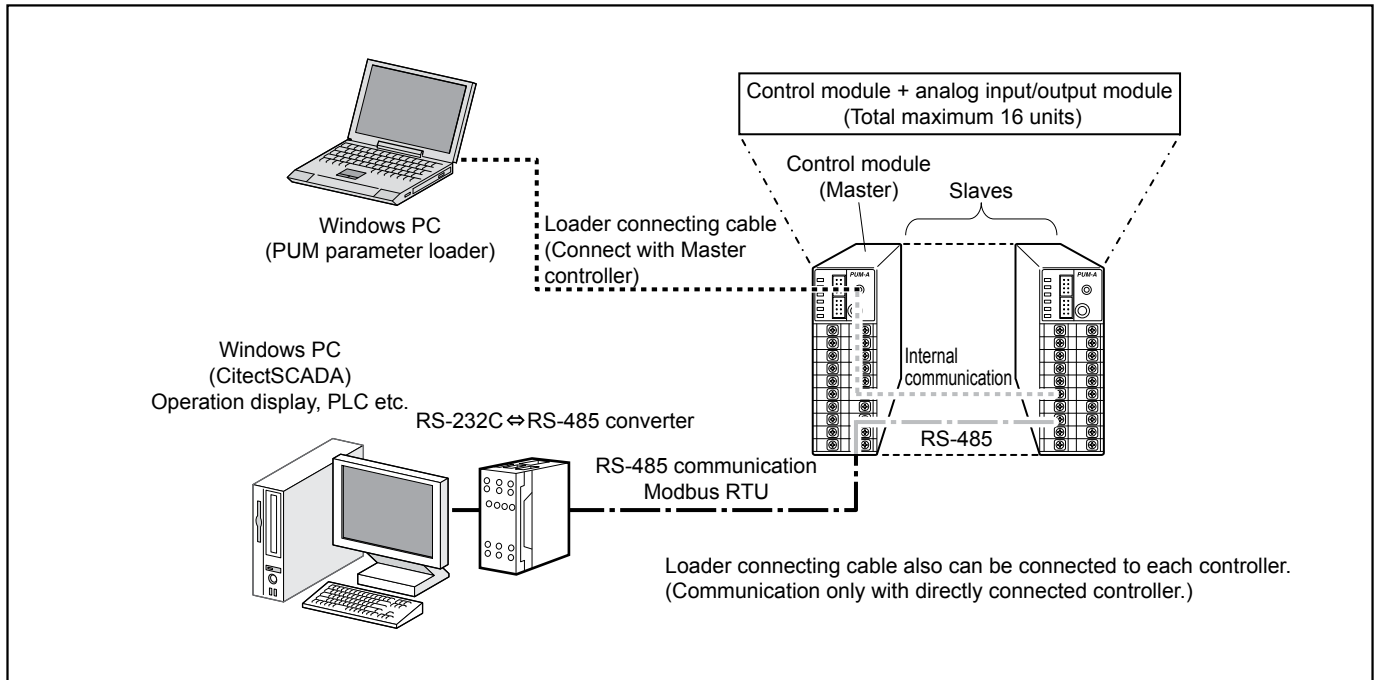

Basic setting items

In case of this example, the following settings are required.

- Station number setting
- Master/slave setting
- RS-485 communication setting
- Output source setting
- Remote SV

System Configuration Using Event Input/Output Module Controllers

The following functions are added if event input/output module are included in the system.

- Control modules are operated by digital input.
- Event output such as alarm and distributed output are possible.

Point

- As for digital input (DI) function, setting source module is designated on the control module.
- As for digital output (DO) function, source module is designated on the event input/output module.

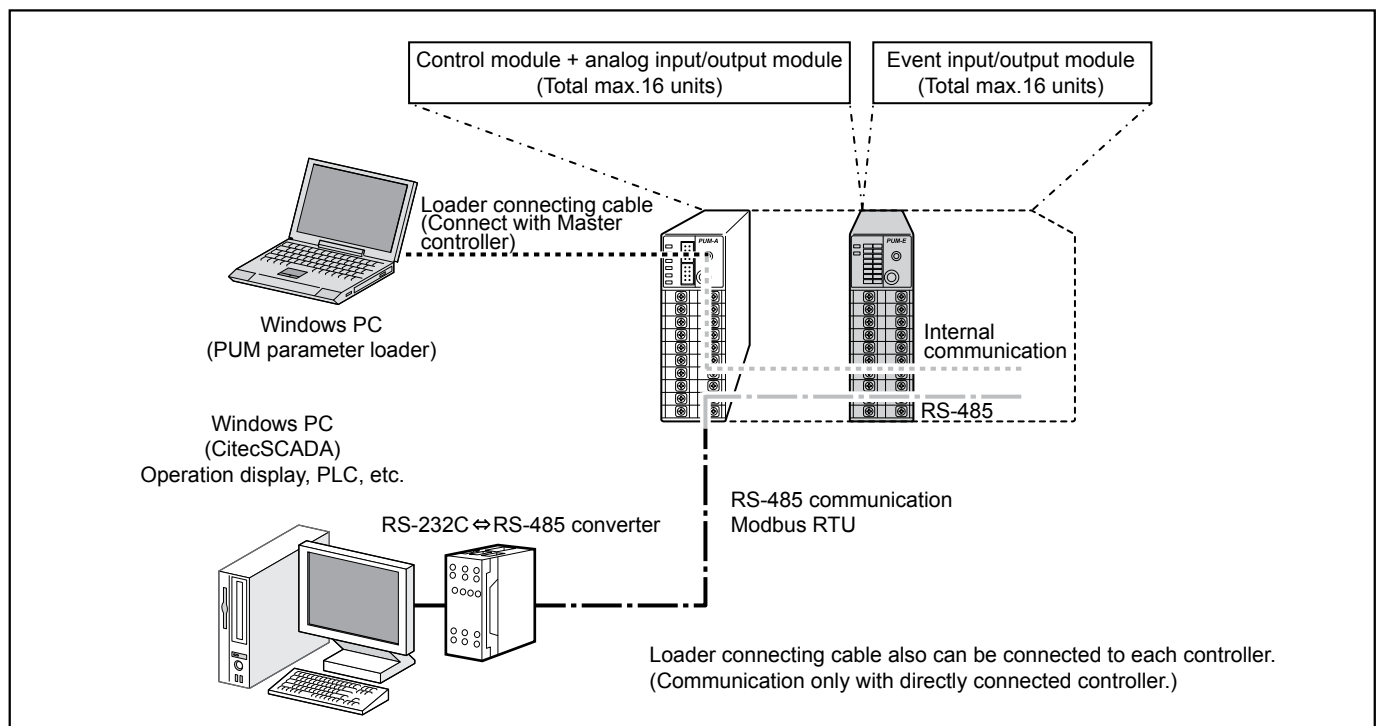

Note

- Station number of event input/output module controller (17 to 32)
The station number of event input/output module must start with "17". Number the rest of controllers consecutively as "17", "18", "32". Make sure that there is no duplicate station number in the same system.

Basic setting items

In case of this example, the following settings are required.

- Station number setting [▶▶ 1-8](#)
- Master/slave setting [▶▶ 4-85](#)
- RS-485 communication setting [▶▶ 4-83](#)
- DI input function [▶▶ 4-88](#)
- Event output setting [▶▶ 4-55](#)
- Output source setting [▶▶ Event input/output user's manual](#)

System Configuration Using Enhanced Communication Module

- By adding enhanced communication module to the system, communication with PLC of various manufactures is possible.

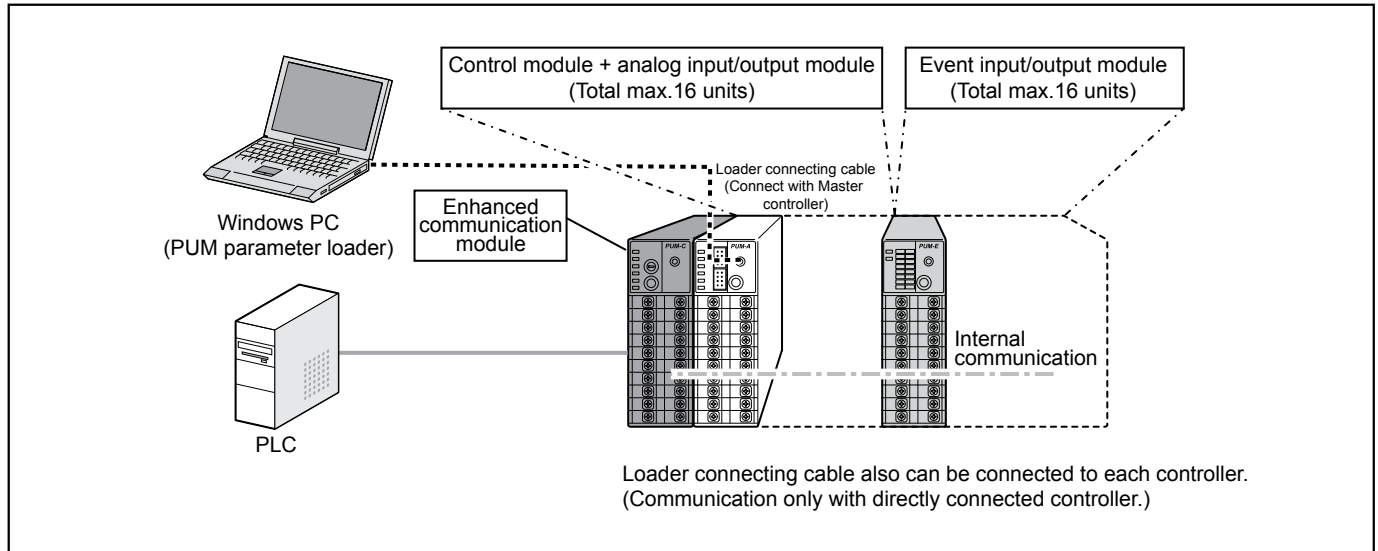

Basic setting items

In the case of communication via CC-Link, the following settings are required.

- Station number setting
- Master/slave setting
- CC Link Station number setting
- CC-Link communication setting

Note

Only connectable modules to an enhanced communication module (CC-Link) are a control module and an event I/O module.

In the case of programless communications, the following settings are required.

- Station number setting
- Master/slave setting
- Programless communication setting

Point

To use enhanced communication module, change the setting of "Enhanced communication module (PUMC) communication permission" to "1:PUMC connected (RS-485 Disable)" on all of connected control module, analog input/output module, and event input/output module.

3

Installation

3.1	Installation Procedure	3-3
3.2	Dimensions	3-8
3.3	Mounting Controllers	3-9
3.4	Attaching Accessories (Optional)	3-14
3.5	Mounting with Screws	3-15
3.6	Terminal Block Diagram	3-16

3.1 Installation Procedure

The procedures from installation to startup via PUM parameter loader software are shown below by each configuration system. Then, the procedures of communication setting of host equipment and trial run are shown.

Stand Alone System

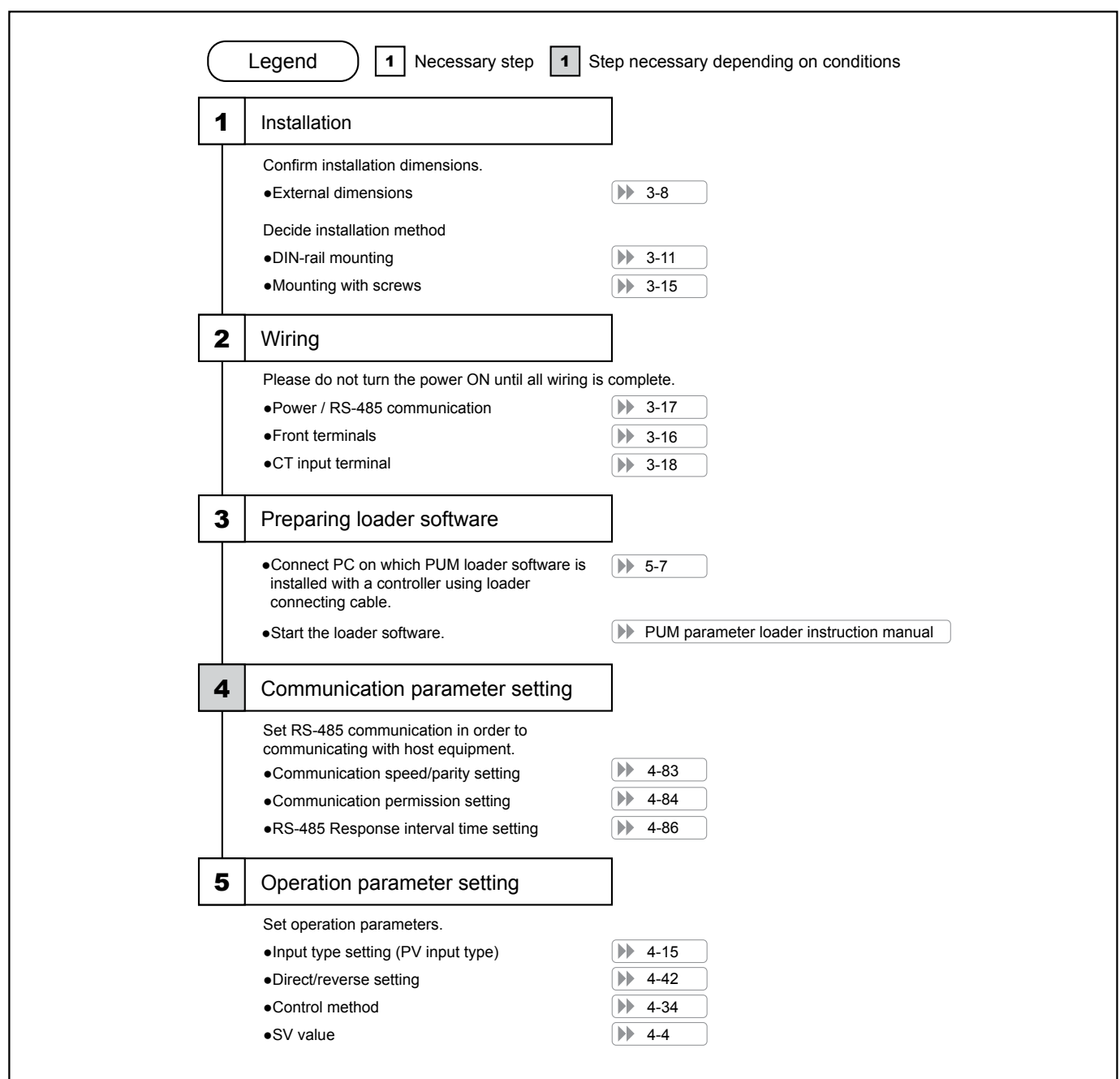

Multi-channel, Stand Alone System

- Station number setting is added.
- To configure parameter, connect each controller with PUM parameter loader software.

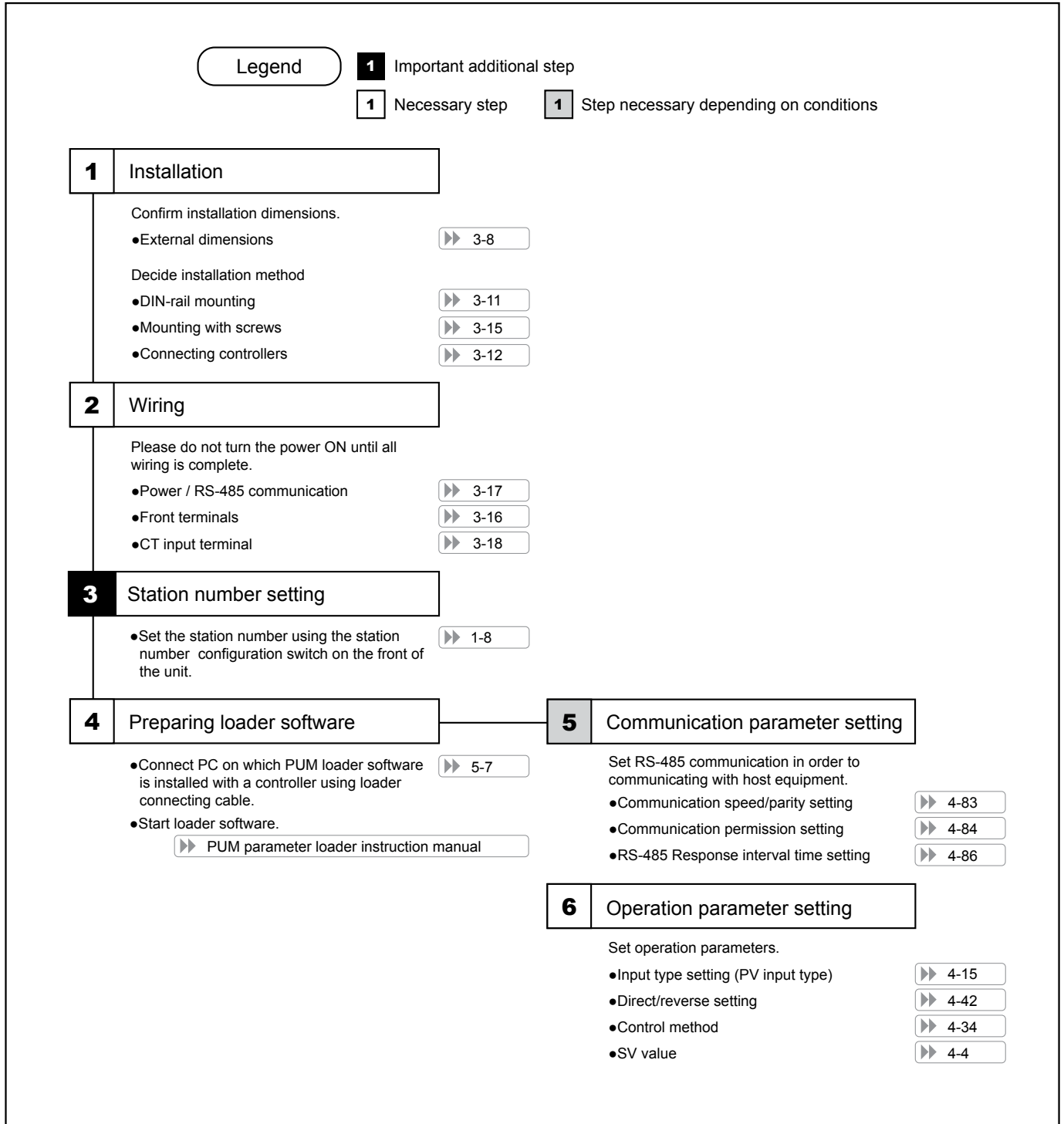

Multi-channel, Master/Slave System

- Station number setting and master/slave setting are added.
- Connect the master controller with PUM parameter loader to configure all controllers at the same time.
- When adding analog input/output module or event input/output module, follow the procedure shown below.

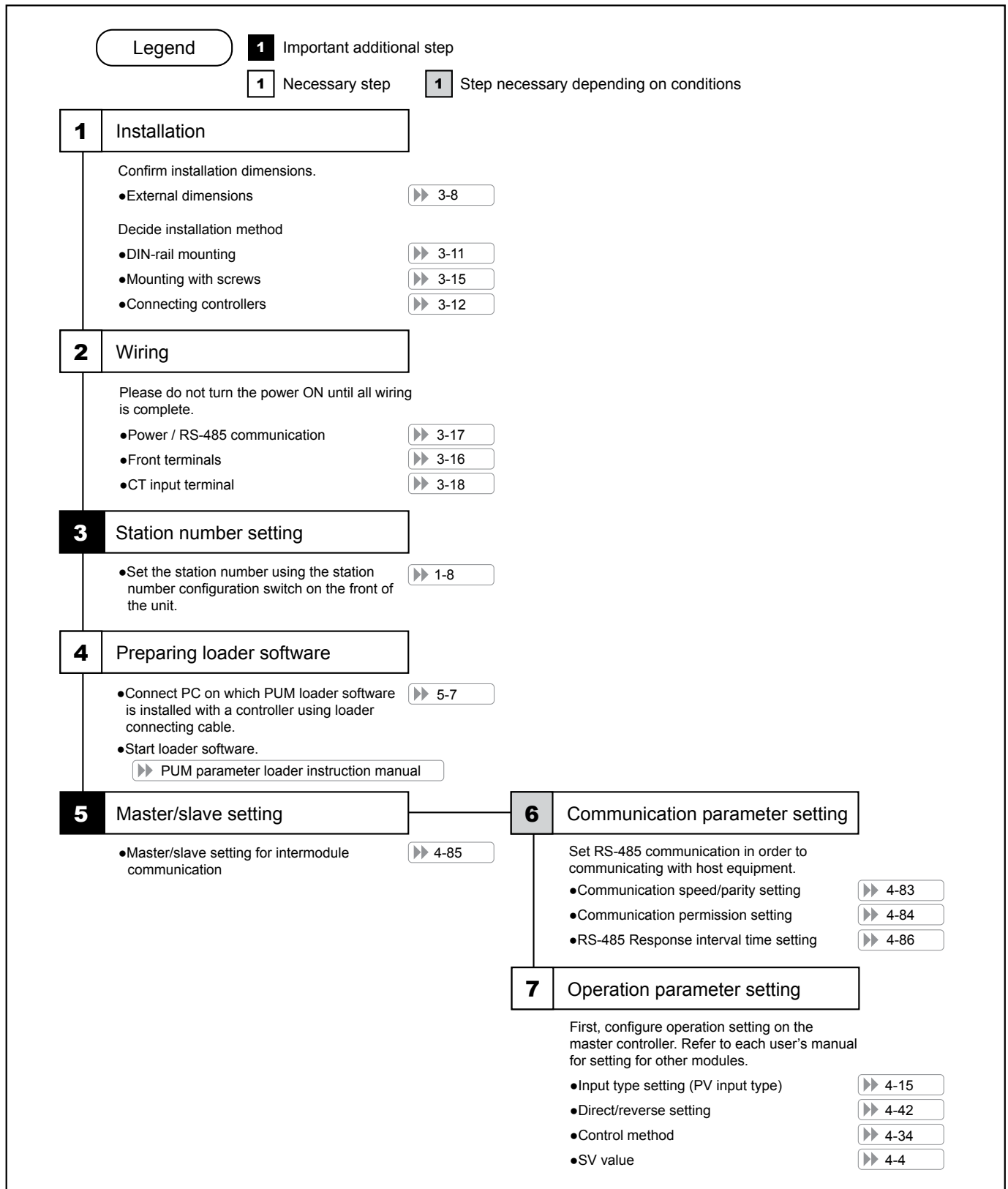

System Configuration Using Enhanced Communication Module

- Station number setting and master/slave setting are added.
- “Enhanced communication module (PUMC) connection permission” parameter setting on all of the control/event/analog module in the system is required to set to “1: PUMC connected (RS-485 Disable)”.
- Connect the master controller with PUM parameter loader to configure all controllers at the same time.
- When setting parameters of the enhanced communication module, connect the parameter loader for PUM directly to the loader communication port of the enhanced communication module.

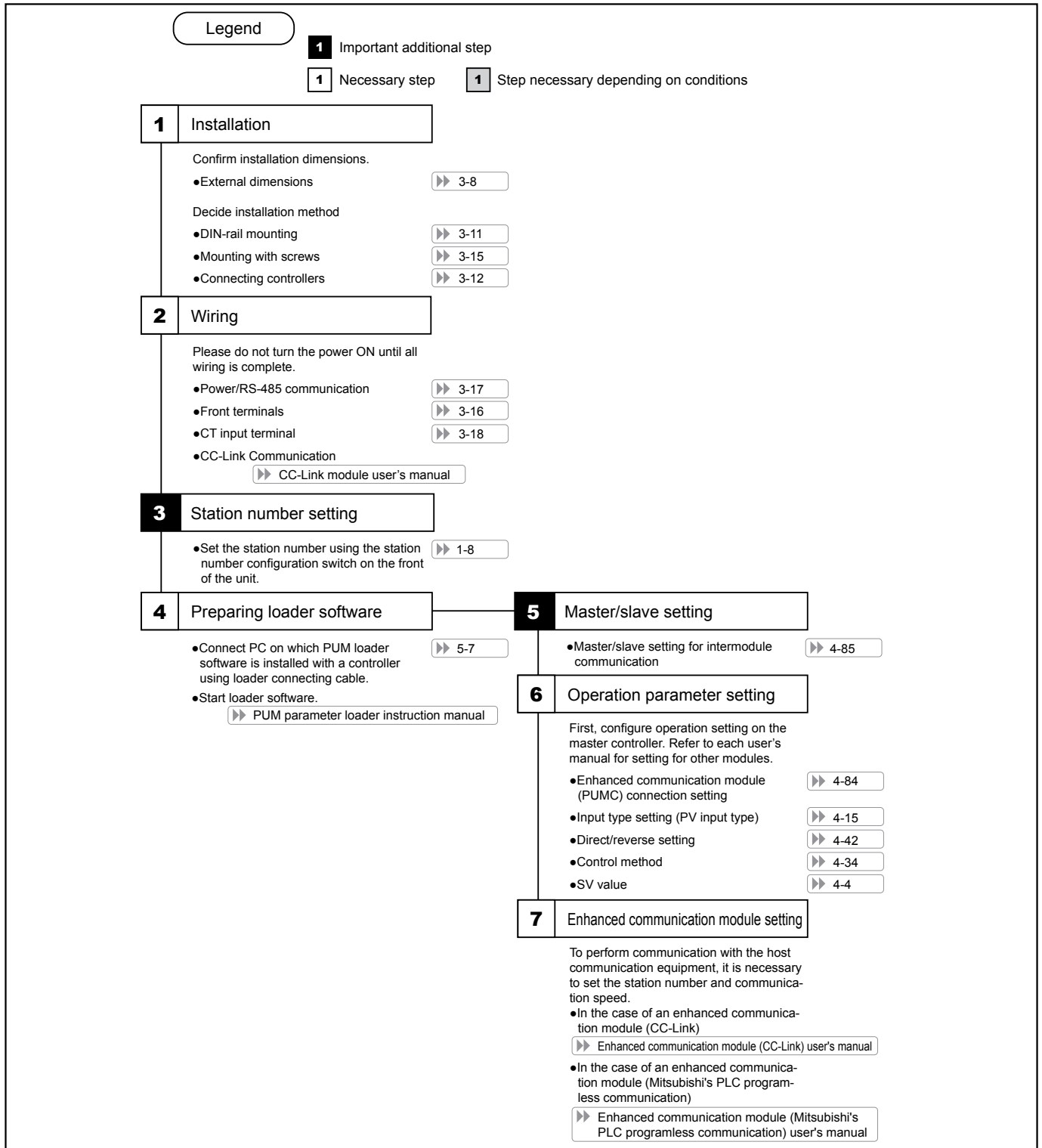

Setting on RS-485 Host Communication Equipment

- The settings on the host communication equipment and PUM must be the same to perform communication correctly.
- Do not turn the power of any controllers ON until all the wiring is complete.

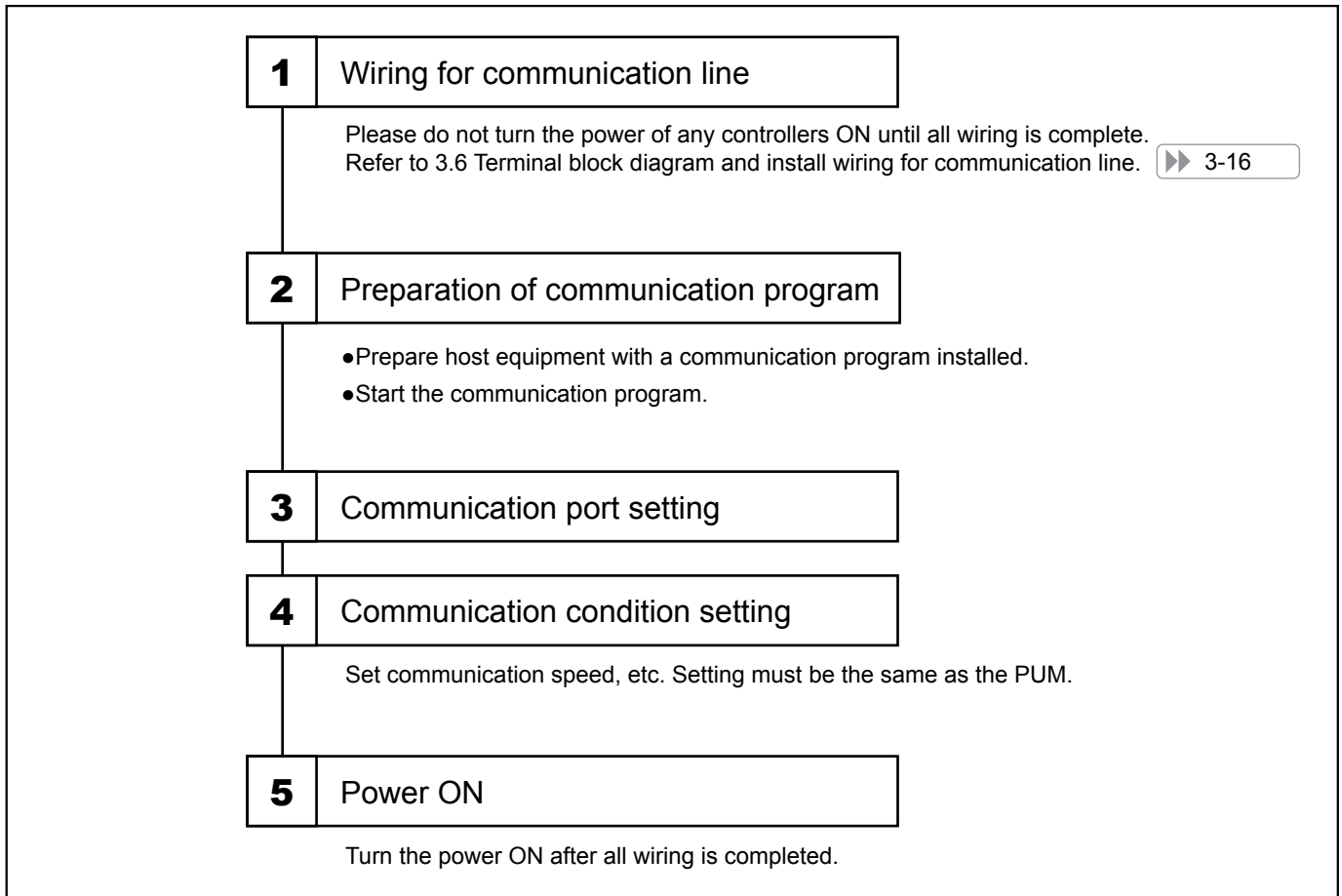

Trial Run

- Perform a trial run after installation and settings are complete.

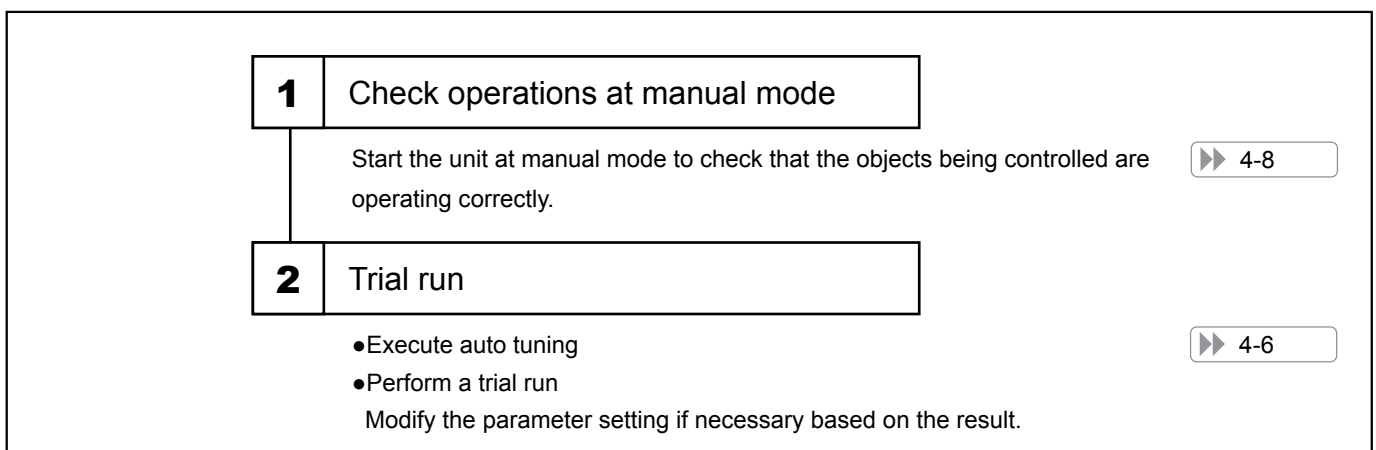

3.2 Dimensions

Dimensions

Refer to the dimensions shown below and provide enough clearance space when installation controllers.

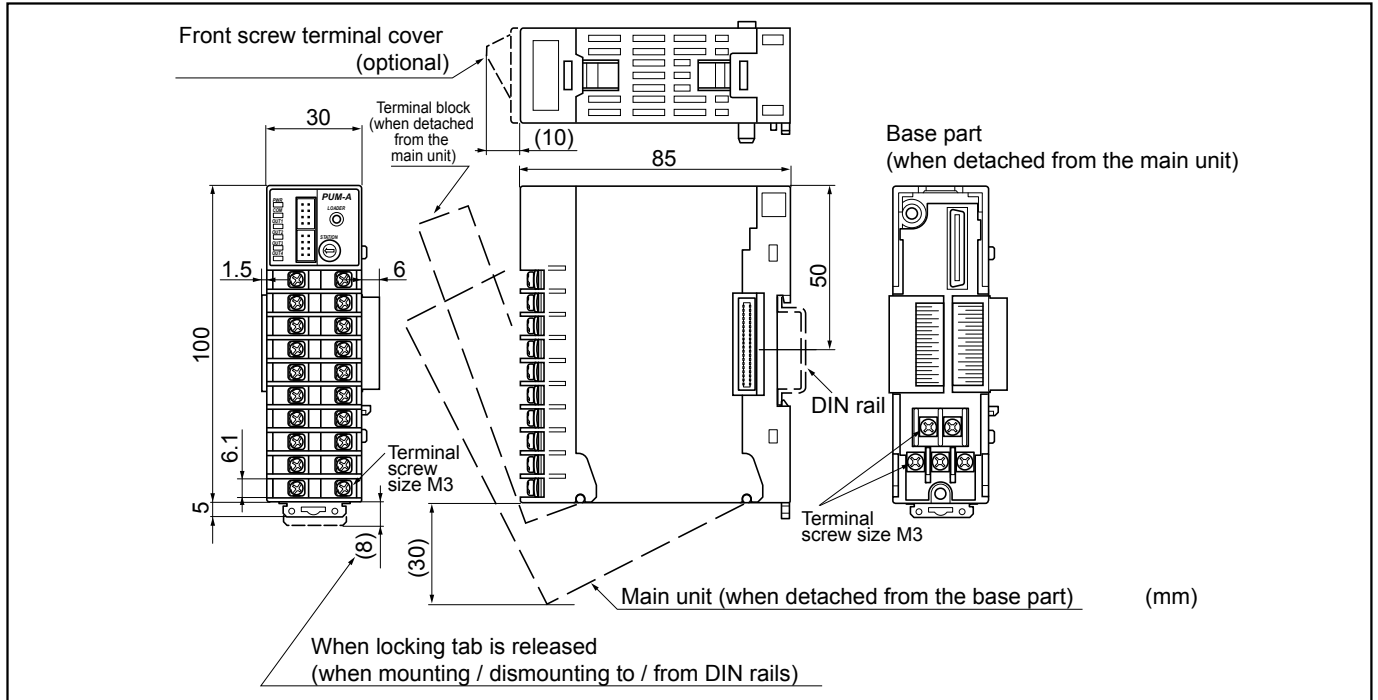

Cautions when mounting

In order to aid heat dissipation, 30mm of clearance (50mm recommended) above and under the controllers should be provided.

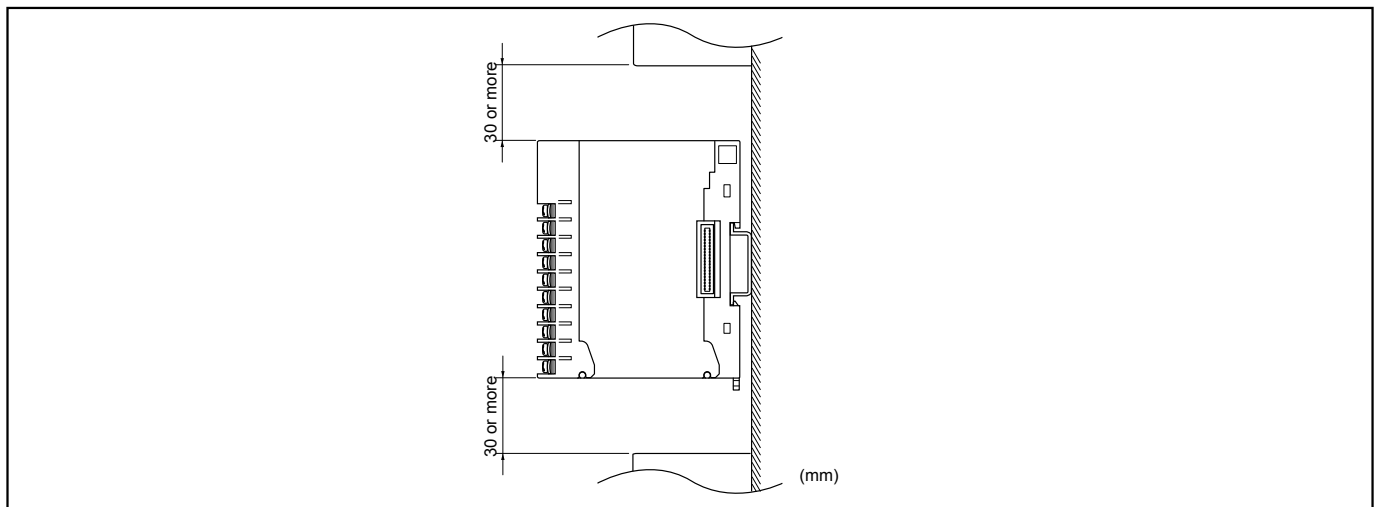

Point

When mounting / dismantling controllers to / from DIN rails, 30mm of clearance above and under the controllers should be provided.

3.3 Mounting Controllers

How to Remove Front Terminal Block / Base Part from the Main Unit

Front terminal block and base part of this equipment are removable from the main unit without tools in seconds, which enables easy mounting and maintenance.

How to remove front terminal block

1. Press the lock lever on the top of the main unit.
2. Pull down the front terminal block.
3. Detach the cutout on the lower end of the front terminal block from the projection on the main unit.

Point

- When attaching the front terminal block to the main unit, take the reverse procedure to removing the front terminal block from the main unit.
- Make sure that the lock lever of the main unit is fitted into the front terminal block.

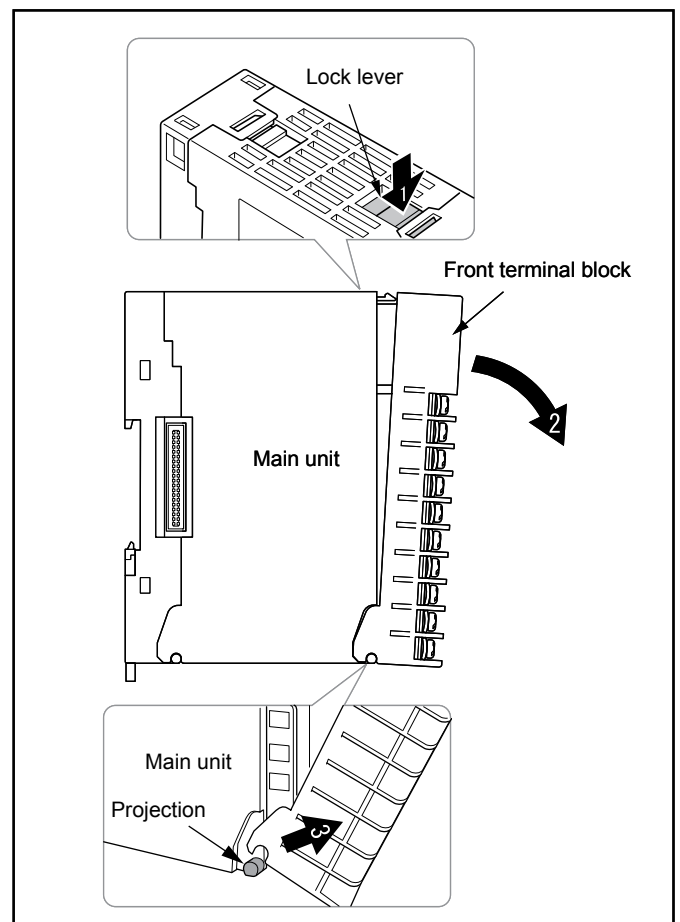

How to remove base part

1. Press the lock lever on the top of the main unit.
2. Pull down the upper part of main unit.
3. Detach the cutout on the lower end of back of main unit from the projection on the base part.

Point

- When attaching the base part to the main unit, take the reverse procedure to removing the base part from the main unit.
- Make sure that the lock lever of the main unit is fitted into the base part.

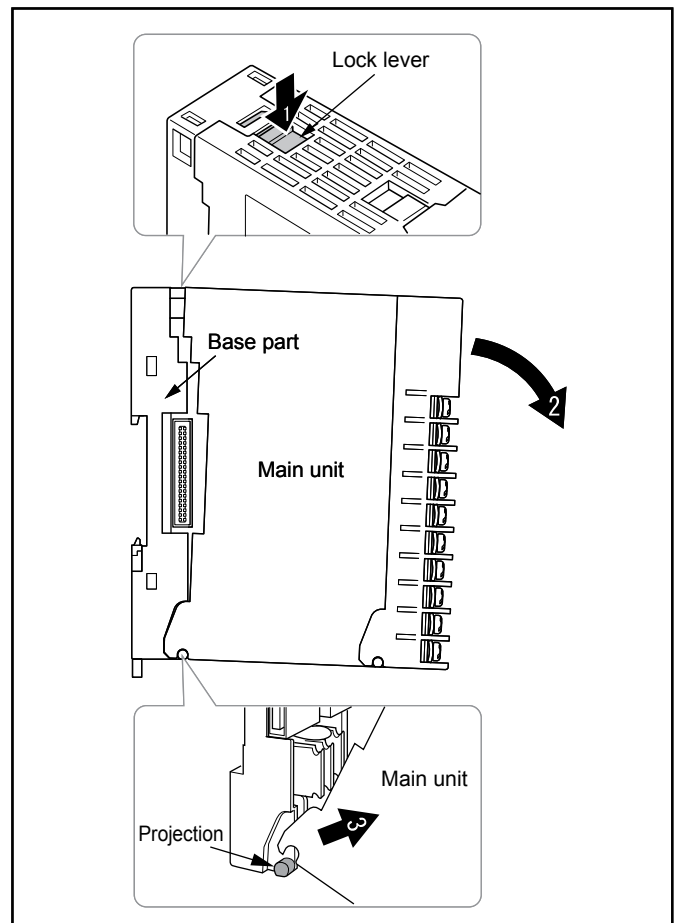

Mounting to DIN Rails

Mount controllers

1. Pull down the locking tab of the base part.
Hook the back of the controller onto the upper part of DIN rail.
2. Push the controller in the direction of arrow 2.

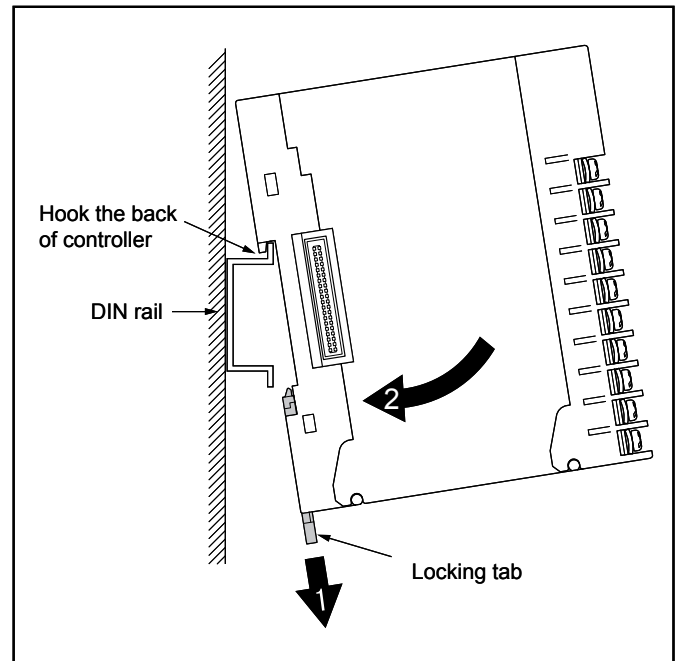

3. Push up the locking tab to fasten the controller onto DIN rail.

Point

- When connecting controllers after mounting to DIN rail, push up the locking tab after doing so.

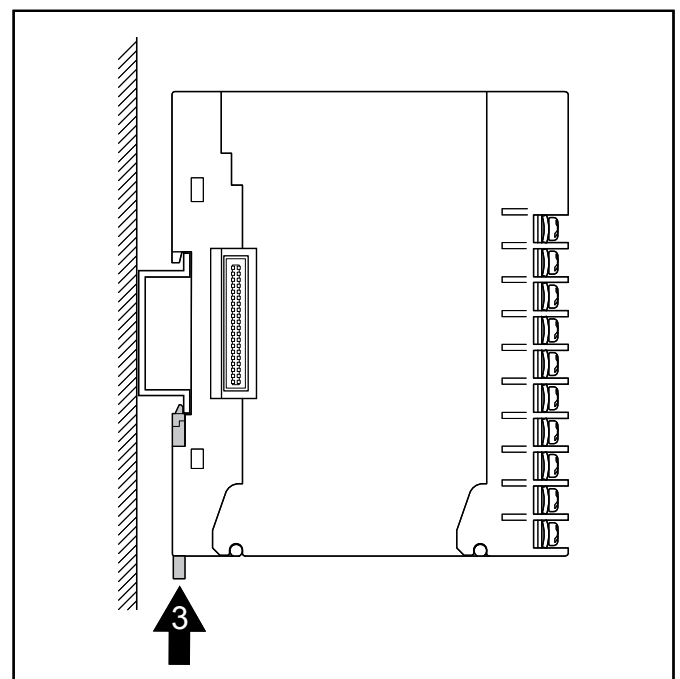

Connecting controllers

- 1. Check that locking tabs are pulled down (released).
- 2. Connect controllers with each other using side connectors.

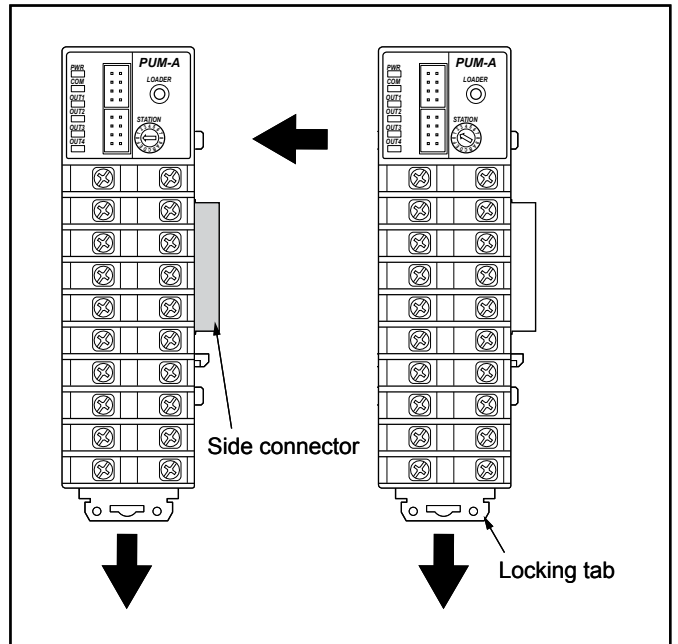

- 3. After mounting connected controllers onto DIN rail, make sure to push up all locking tabs. Controllers are fastened to DIN rail and to each other.
- 4. All connected controllers are connected to power supply and RS-485 via side connectors if one of controllers is directly connected to them.

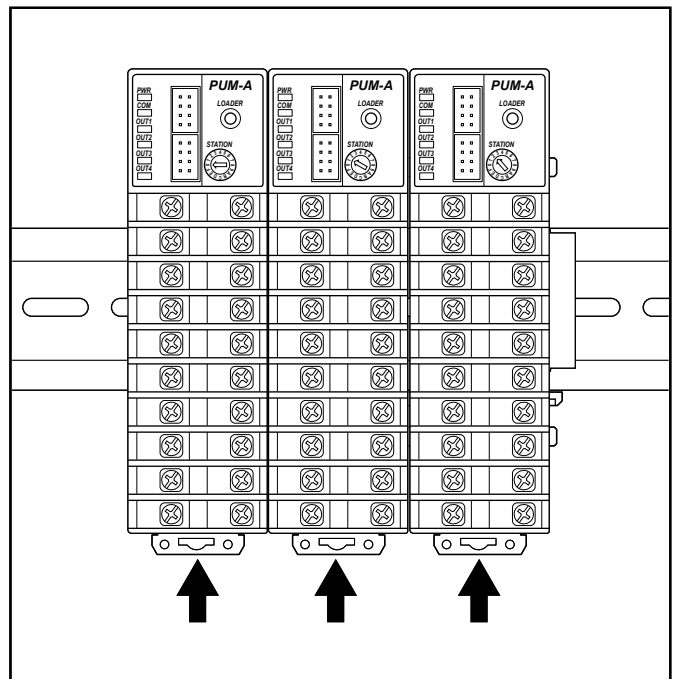

Order of Controllers

PUM series module type temperature controllers should be connected in the order shown below.

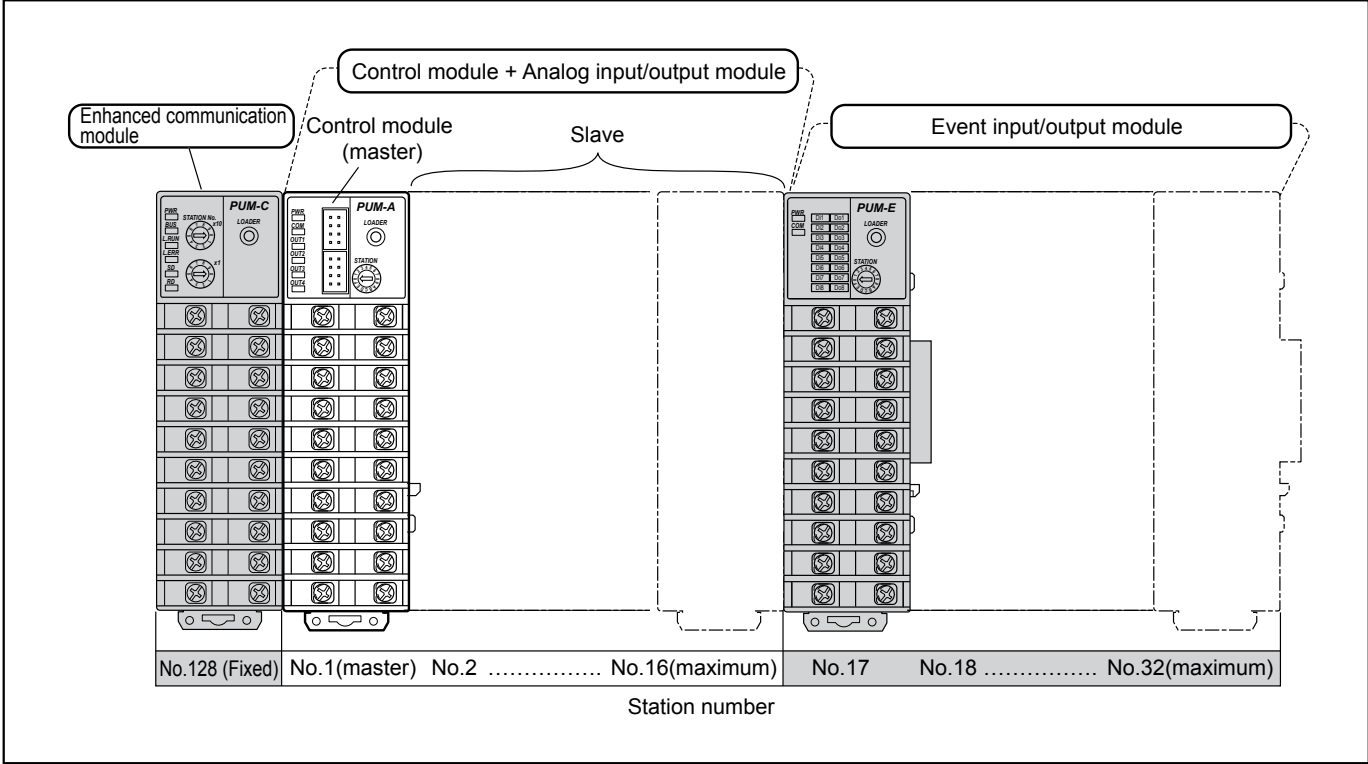

Point

Basically connect controllers from left to right in the order of station number.

- Assign station numbers 1 to 16 to control module and analog input/output module. Maximum 16 units in total can be connected. Make sure that there is no duplicate station number in the same system.
- When setting slave or master, set the control module controller of station No.1 as the master controller. The master controller should be on the extreme left if an enhanced communication module is not used.
- Assign station numbers 17 to 32 to event input/output module. Maximum 16 units can be connected. Make sure that there is no duplicate station number in the same system.

When using an enhanced communication module, always remember to place it on the extreme left.

- An enhanced communication module should be on the left of the master control module controller, which places it at the far left end of connected controllers.

3.4 Attaching Accessories (Optional)

Attaching Side Connecting Terminal Covers

Side connectors on the both ends of connected controllers are exposed. To prevent accidents and to protect them, we recommend to attach side connecting terminal covers (PUMZ*A03) to the ends of the rightmost and leftmost controllers.

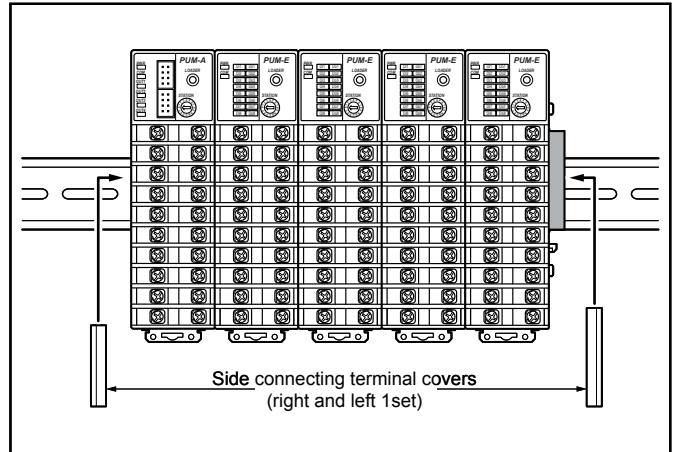

Attaching End Plates

In order to secure controllers onto DIN rail more tightly, end plates (PUMZ*A02) are also available.

Note

- When attaching end plates, make sure to attach side connecting terminal covers first.

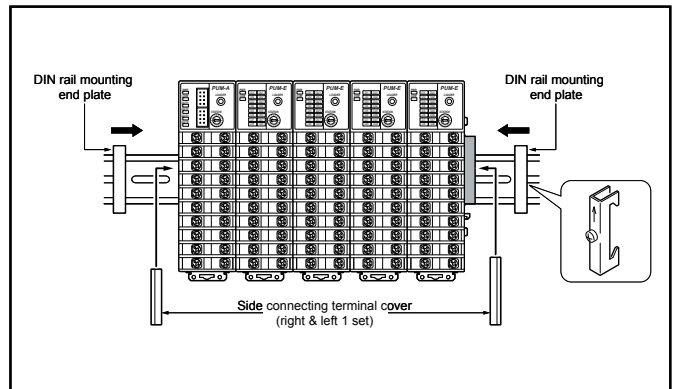

3.5 Mounting with Screws

When mounting controllers with screws inside a cabinet, check the screw hole size of the base part and the mounting position beforehand.

Point

- Mounting screws are not included in the product. Prepare two M3 screws per unit.
 1. Refer to the right figure for the mounting screw hole size and the pitch to decide the mounting position.

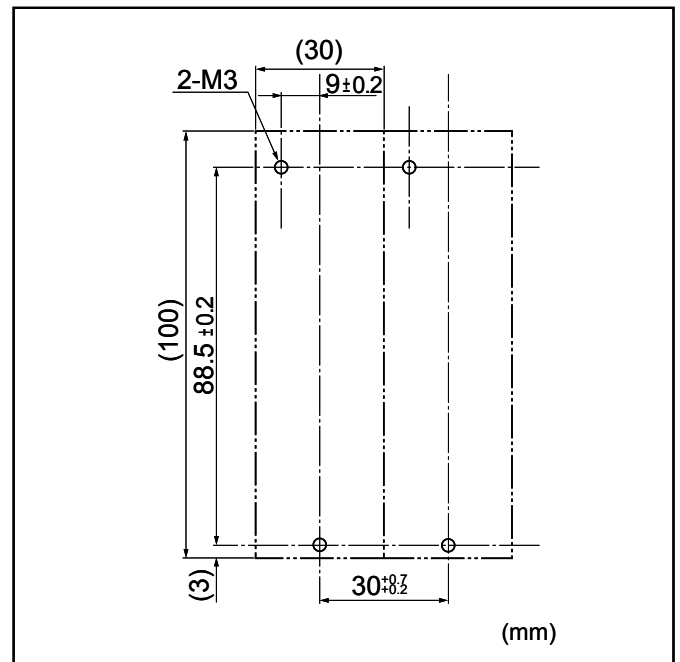

2. Remove the main units from the base parts.

(3.3 Mounting controllers) [▶▶ 3-9](#)

3. Connect base parts. Push up to fasten all the locking tabs.
4. Fixate the base parts onto the mounting position inside the cabinet with screws.
5. Attach the main units to the base parts.

3.6 Terminal Block Diagram

Wiring

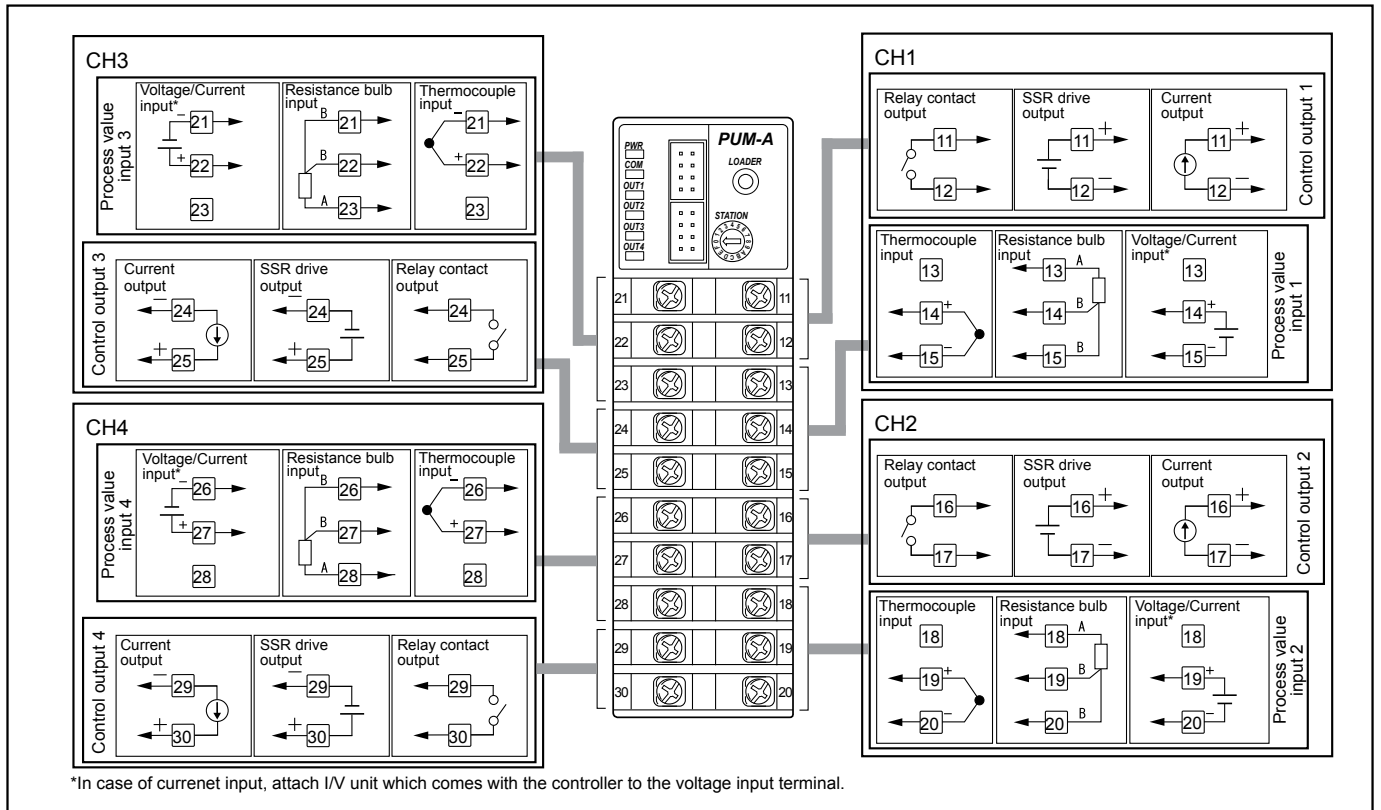

Point

- Input terminal of CH3 and CH4 cannot be used on PUMB. However, output terminal of CH3 and CH4 can be used depending on the model code.
- Note that the insulation class for this equipment is as follows. Before installing, please confirm that the insulation class for the equipment meets usage requirements.

Power	PV1
Loader communication port	PV2
RS-485 communication port	PV3
CT Input (CT1A, B - CT4A,B)	PV4
OUT1 (relay contact output)	OUT1(SSR drive, current)
OUT2 (relay contact output)	OUT2(SSR drive, current)
OUT3 (relay contact output)	OUT3(SSR drive, current)
OUT4 (relay contact output)	OUT4(SSR drive, current)

Basic insulation (1500VAC)
 Functional insulation (1000VAC)
 Functional insulation (500VAC)

Wiring for Power Supply / RS-485

Terminal layout

Power terminal and RS-485 terminal are on the base part of each controller.

The terminal layout of all controllers is the same.

Power supply and RS-485 are connected to connected controllers via side connectors if one of controllers is directly connected to them.

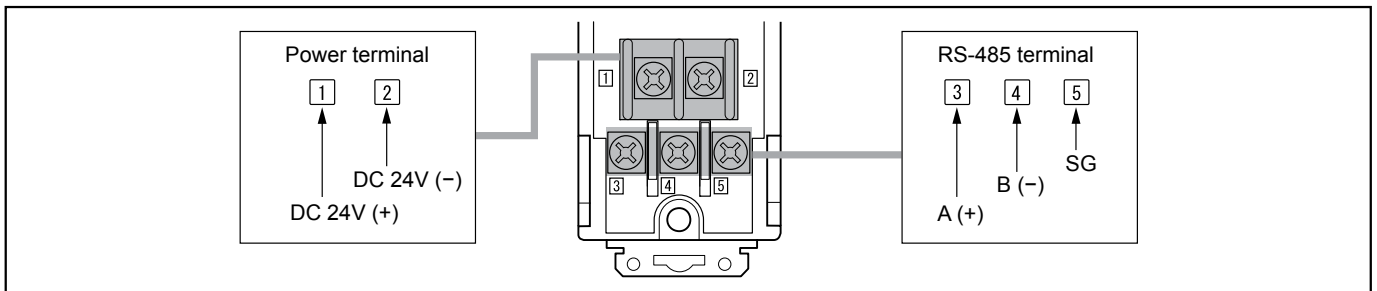

Note

- For wiring to the terminal block, apply crimp type terminals size M3.
Make sure to use screws included in this product only.

Screw size	: M3 x 7 (with square washer)
Screw tightening torque	: 0.78N•m (8kgf•cm)
- Apply power cable with allowable current capacity larger than the total consumption current of all connected controllers.
- For wiring to RS-485, a cable equivalent to KPEV-SB 0.5sq should be used.
- For wiring to power terminal, do not apply more than two cables to one terminal.
(Power cable should be connected to power terminal directly from the power unit.)
- Please prepare power cables and crimp terminals of the size indicated below.

Power cable

Cable type	Size
Thermocouple (Compensation lead wire)	1.25mm ² or less
Power supply	1.25mm ² or less

Crimp terminal

Cable size	Screw tightening torque
0.25 to 1.25mm ²	0.8 N•m

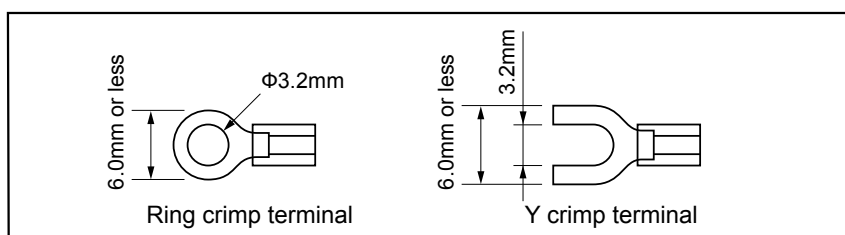

Connection of RS-485 terminating resistance

RS-485 terminating resistance should be connected to the controller at the opposite end from the controller to which RS-485 communication line is connected.

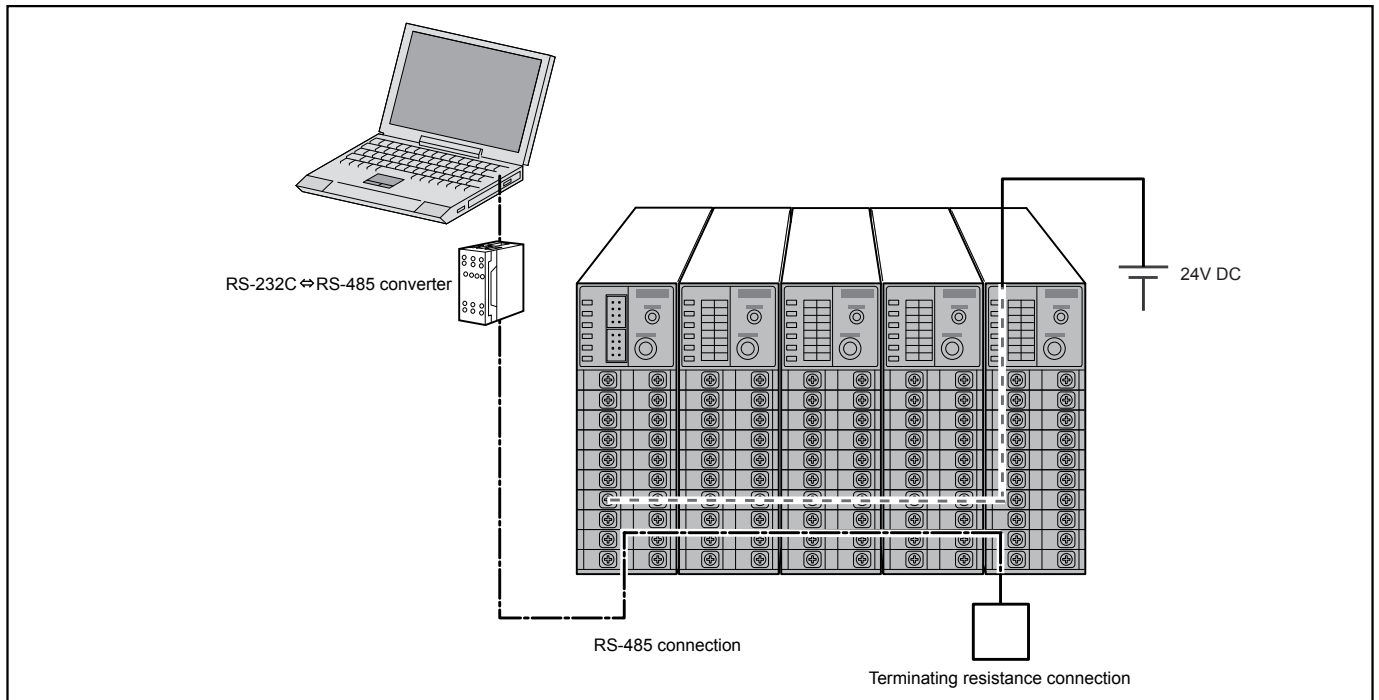

Wiring for Heater Break Detection CT

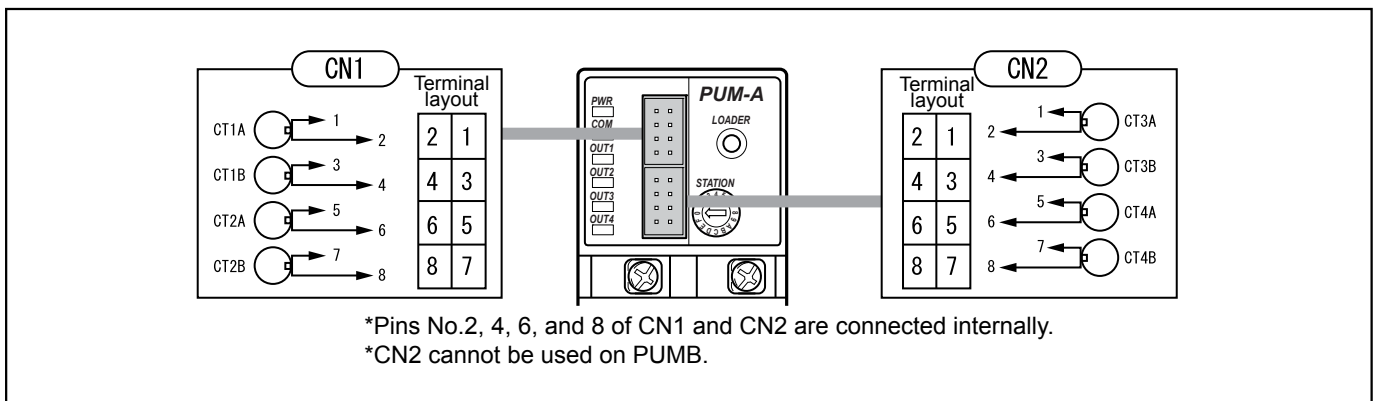

Note

- The shape of CT input terminal is unique. Special connecting cable for CT input terminal is required.

Prepare 1 set per 4 points of input, which means 1 set each is required for CN1 and CN2.

Connecting cable for CT input terminal (for 4 points of input)

- : PUMZ*C01 (L=1m)
- : PUMZ*C03 (L=3m)
- : PUMZ*C05 (L=5m)

4

System Setting

4.1	Operating Method	4-3
4.2	Input Setting	4-13
4.3	Output Setting	4-25
4.4	Control Setting	4-33
4.5	Event Output Setting	4-55
4.6	Communication Setting	4-83
4.7	Optional functions Setting	4-87

4.1 Operating Method

Operating Method

Following settings can be performed during operation.

Basic operation

- SV value setting [▶▶ 4-4](#)
- MV value setting [▶▶ 4-5](#)
- Running Auto-tuning [▶▶ 4-6](#)

Operation mode switching

- Auto/manual switch [▶▶ 4-8](#)
- Run/Standby switch [▶▶ 4-9](#)
- Remote/Local switch [▶▶ 4-10](#)
- Digital output latch release [▶▶ 4-11](#)

Control output values during operation

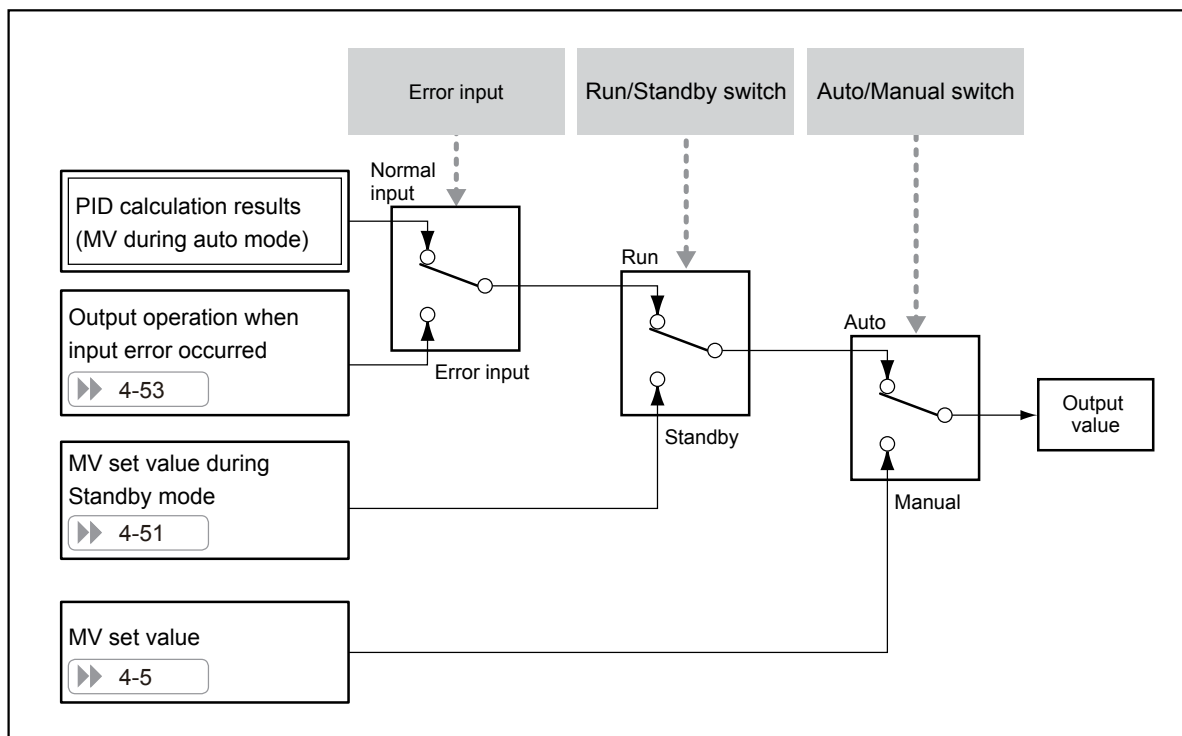

SV Value Setting

This is setting for the SV value which is used during Local operation. [▶▶ 4-10](#)

The parameter to set SV value has the local SV value and the communication SV value.

If a SV value is often changed, use a communication SV value.

(Because a local SV value is limited in number of rewriting the internal memory of the main unit)

Each channel (Ch1 to Ch4) has parameters shown below.

Parameter	Range	Unit	Factory default	Attribute	Modbus register number (relative address)
Local SV value	SV limit (lower) to SV limit (upper)	%FS	0	R/W	Ch1: 40001 (0000h) 41001 (03E8h)
					Ch2: 40002 (0001h) 42001 (07D0h)
					Ch3: 40003 (0002h) 43001 (0BB8h)
					Ch4: 40004 (0003h) 44001 (0FA0h)
Communication SV value	SV limit (lower) to SV limit (upper)	%FS	0	R/W	Ch1: 40023 (0016h) 41100 (044Bh)
					Ch2: 40024 (0017h) 42100 (0833h)
					Ch3: 40025 (0018h) 43100 (0C1Bh)
					Ch4: 40026 (0019h) 44100 (1003h)

A local SV value is limited in the “SV upper/lower limit” [▶▶ 4-46](#), it can be offset by the “SV set value shift setting”

[▶▶ 4-47](#)

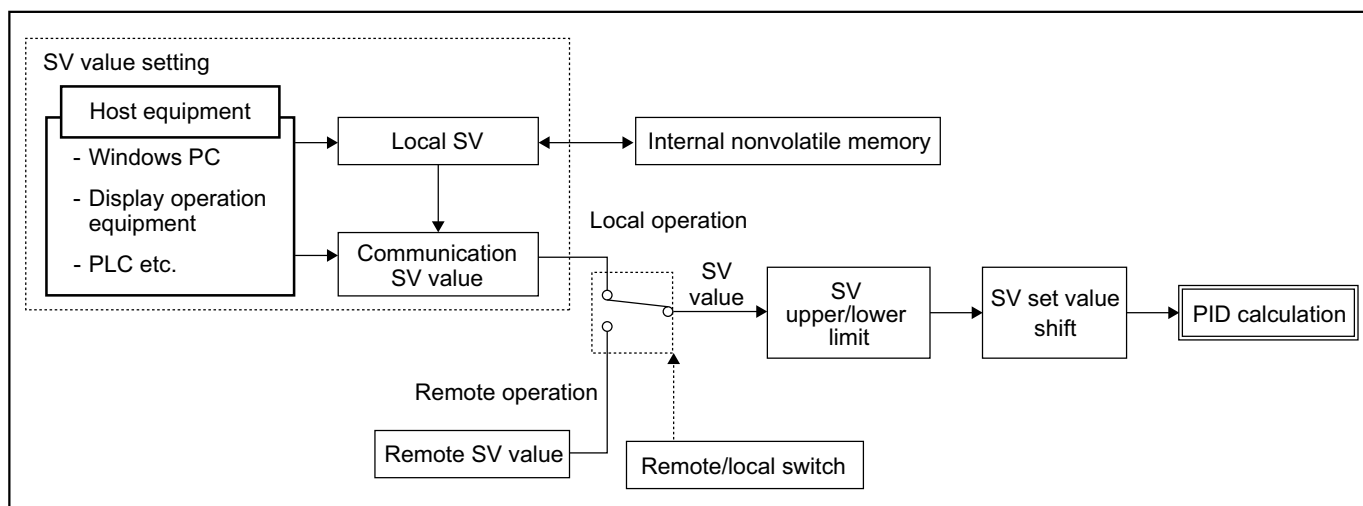

- **Local SV value:** The SV value that values are stored in an internal nonvolatile memory.
When the power on, starts operation at the SV value that is same as the value before turning the power off.
- **Communication SV value:** The SV value that the values are not stored.
When the power on, starts operation at the same value as the local SV value.
If the local SV value is changed, the communication SV value is also changed to the same value.

Examples of use

- when the SV value is changed during operation
- In the case although the SV value is changed sometimes during operation, want to fix the certain SV value at startup.

Note

- Do not change the SV value during remote operation. [▶▶ 4-10](#)
- When change the SV value, or the change from the remote operation to the local operation, the SV value is stored.
- When using an enhanced communication module (Mitsubishi's PLC programless communication, CC-Link communication, and RS-485 high-speed communication), use a communication SV value. A local SV value is not possible to register.

MV Value Setting

Sets the control output value.

Each channel (Ch1 to Ch4) has parameters shown below.

Parameter	Range	Unit	Factory default	Attribute	Modbus register number (relative address)
MV value	-3.0 to 103.0	%	0	R/W	Ch1: 40005 (0004h) 41002 (03E9h)
					Ch2: 40006 (0005h) 42002 (07D1h)
					Ch3: 40007 (0006h) 43002 (0BB9h)
					Ch4: 40008 (0007h) 44002 (0FA1h)

During Auto mode operation, the current PID calculation results are written in the relevant register. It is possible to write MV value in a register manually, however, the written values will not be reflected. [▶▶ 4-8](#)

During Manual mode operation, the current MV value can be set. [▶▶ 4-8](#)

Running Auto-tuning

Running Auto-tuning automatically sets the optimal PID parameters.

Before running Auto-tuning, the following parameter setting is required.

- PV input type, PV input scale lower and upper, Decimal place setting ▶▶ 4-15
- Output proportion cycle (Relay output or SSR drive output is selected) ▶▶ 4-26
- Current output range ▶▶ 4-27

Point

Followings are PID parameters.

- Proportional band [P] ▶▶ 4-37
- Integration time [I] ▶▶ 4-37
- Derivative time [D] ▶▶ 4-37
- Anti-reset windup [ARW] ▶▶ 4-39

Note

Do not run Auto-tuning in facilities such as pressure or flow controls where rapid response is required.

ON/OFF (2 position) control is used during Auto-tuning, which may cause large changes in PV depending on circumstances.

If you are running a process that cannot tolerate large changes in PV, refrain from using auto-tuning.

Each channel (Ch1 to Ch4) has parameters shown below.

Parameter	Range	Unit	Factory default	Attribute	Modbus register number (relative address)
Auto-tuning RUN command	0: Stop/End 1: Normal type 2: Low PV type	None	0	R/W	Ch1: 41005 (03ECh)
					Ch2: 42005 (07D4h)
					Ch3: 43005 (0BBCh)
					Ch4: 44005 (0FA4h)

Set value of Auto-tuning RUN command

Refer to the table below and decide the set value.

Set value	Operation mode	Function
0	Stop/End	Stop or end Auto-tuning
1	Normal type	Auto-tuning with SV as the baseline. Normally select this type.
2	Low PV type	Requests PID and ON/OFF operation at a baseline of SV-10%. Use this setting if you are trying to prevent overshoot.

- Auto tuning action when set value is "1".

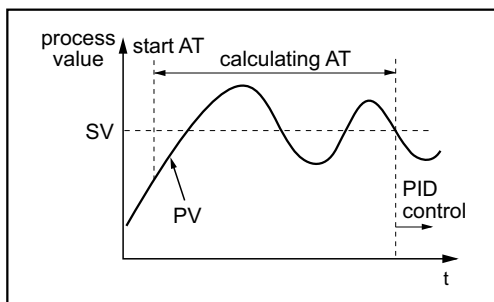

- Auto-tuning action when set value is "2".

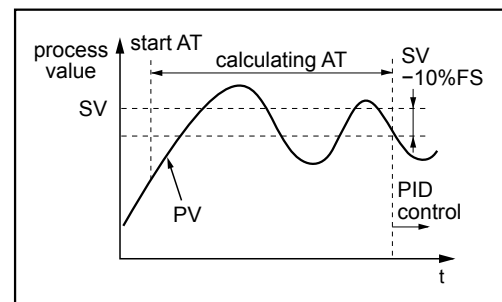

Instructions on running Auto-tuning

Auto-tuning will not be performed in manual mode [▶▶ 4-8](#) or standby mode [▶▶ 4-9](#)

The PID parameters after Auto-tuning has finished normally will be saved even if power is cut off.

Note

PID parameters will not be changed if the power is cut OFF during Auto-tuning.

In such a case, run Auto-tuning again if necessary.

If Auto-tuning has not finished after four or more hours have passed, check the followings;

- Input/output connections [▶▶ 3-16](#)
- Direct/Reverse action setting [▶▶ 4-42](#)
- PV input basic setting [▶▶ 4-15](#)

In the following cases, Auto-tuning must be restarted.

- Large change in SV [▶▶ 4-4](#)
- Change in PV input type, PV input scale lower and upper [▶▶ 4-15](#)
- Large change in the condition of controlled target

Auto/Manual Switch

The setting of whether control output should be calculation results or the manually set value is performed. [▶▶ 4-5](#)

Each channel (Ch1 to Ch4) has parameters shown below.

Parameter	Range	Unit	Factory default	Attribute	Modbus register number (relative address)
Manual mode switch	0: Auto 1: Manual	None	0	R/W	Ch1: 40013 (000Ch) 41003 (03EAh)
					Ch2: 40014 (000Dh) 42003 (07D2h)
					Ch3: 40015 (000Eh) 43003 (0BBAh)
					Ch4: 40016 (000Fh) 44003 (0FA2h)

When the set value is "0:Auto", calculation results will be output as control output, while the set value is "1:Manual", MV set value (See MV value setting [▶▶ 4-5](#)) will be output.

Point

- When the mode is switched to "1:Manual" during Auto-tuning [▶▶ 4-6](#), Auto-tuning will be stopped. To run Auto-tuning, switch to "0:Auto" mode.
- In Manual operation, MV set value (See MV value setting [▶▶ 4-5](#)) will be output even if an input error occurred.
- When DI function No.2 (See DI function select [▶▶ 4-88](#)) is assigned, Auto/Manual switch can be activated by digital input.

RUN/Standby Switch

The setting of whether the operation mode should be RUN or Standby is performed.

Each channel (Ch1 to Ch4) has parameters shown below.

Parameter	Range	Unit	Factory default	Attribute	Modbus register number (relative address)
RUN/Standby switch	0: RUN 1: Standby	None	0	R/W	Ch1: 40017 (0010h) 41004 (03EBh)
					Ch2: 40018 (0011h) 42004 (07D3h)
					Ch3: 40019 (0012h) 43004 (0BBBh)
					Ch4: 40020 (0013h) 44004 (0FA3h)

Refer to Standby MV value setting [▶▶ 4-51](#) for setting detail of output value and alarm output in Standby operation.

Point

When DI function No.1 (See DI function select [▶▶ 4-88](#)) is assigned, RUN/Standby switch can be activated by digital input.

Note

- When the mode is switched to “1:Standby” during Auto-tuning [▶▶ 4-6](#), Auto-tuning will be stopped. To run Auto-tuning, switch to “0:RUN” mode.
- When Standby mode, the delay on timer will be reset. It will be activated again when the mode is switched to “0:RUN”.

Remote/Local Switch

The setting of whether to use local SV value [▶▶ 4-4](#) or Remote SV value is performed.

Each channel (Ch1 to Ch4) has parameters shown below.

Parameter	Range	Unit	Factory default	Attribute	Modbus register number (relative address)
Remote mode switch	0: Local 1: Remote	None	0	R/W	Ch1: 40009 (0008h) 41007 (03EEh)
					Ch2: 40010 (0009h) 42007 (07D6h)
					Ch3: 40011 (000Ah) 43007 (0BBEh)
					Ch4: 40012 (000Bh) 44007 (0FA6h)

When the set value is "0:Local", local SV value (See SV value setting [▶▶ 4-4](#)) is adopted.

When the set value is "1:Remote", Remote SV value (See Remote SV input source setting [▶▶ 4-22](#)) which is input from the designated channel is adopted

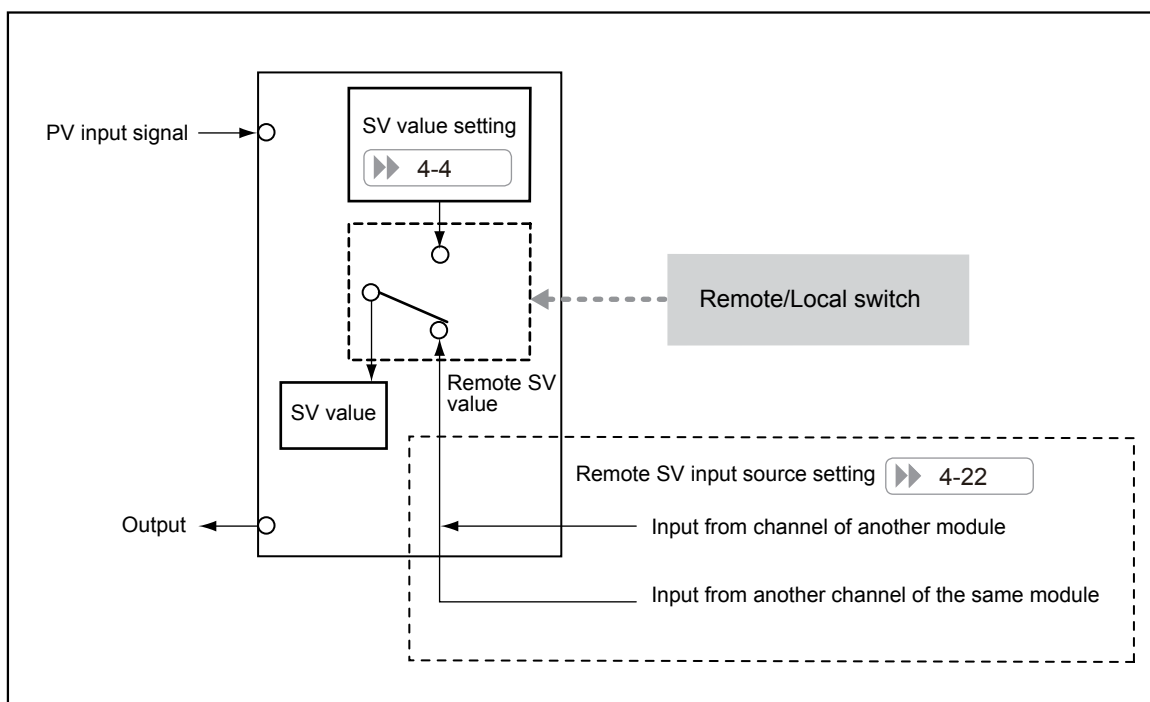

Point

When DI function No.3 (See DI function select [▶▶ 4-88](#)) is assigned, Remote/Local switch can be activated by digital input.

Digital Output Latch Release

The setting of whether to release digital output latch or not is performed.

Each channel (Ch1 to Ch4) has parameters shown below.

Parameter	Range	Unit	Factory default	Attribute	Modbus register number (relative address)
Digital output latch release command	0: OFF 1: Release latch	None	0	R/W	Ch1: 41031 (0406h)
					Ch2: 42031 (07EEh)
					Ch3: 43031 (0BD6h)
					Ch4: 44031 (0FBEh)

When the set value is "1:Release latch", digital output (DO1 to DO5) latch will be released simultaneously.

Note

- When DI function No.17 (See DI function select [▶▶ 4-88](#)) is assigned, Digital output latch release command can be activated by digital input.
- When DI function No.18 to 22 (See DI function select [▶▶ 4-88](#)) are assigned, Digital output (DO1 to DO5) latch will be released separately.

4.2 Input Setting

Input Setting

Followings are settings related to PV input.

The parameters reset the main unit is necessary when change the setting are marked (RST) in each setting explanation or parameter.

Note

There are two types of control module, 4Ch control module and 2Ch control module. Those settings are required for each input channel.

The following setting is inevitable.

- PV input basic setting ▶▶ 4-15

The following settings are configured as needed.

- PV input filter setting ▶▶ 4-18
- PV input shift setting ▶▶ 4-19
- PV display zero & span adjustment setting ▶▶ 4-20
- Cold junction compensation setting ▶▶ 4-21

The following settings are required when using Remote SV function.

- Remote SV input source setting ▶▶ 4-22
- Remote SV zero & span adjustment setting ▶▶ 4-23

4.2 Input Setting

Point

In remote SV function, PV input signal from another channel in the same module, or from channel of another module is used as SV value.

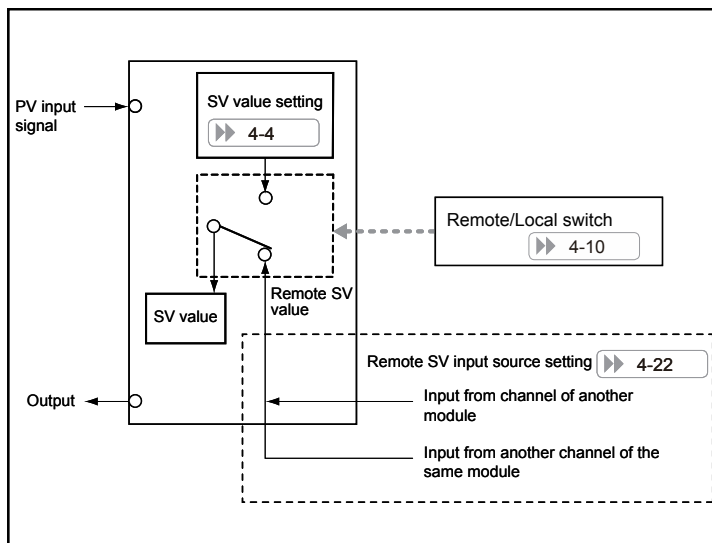

Note

PV input setting is required separately on the channel, which is the input source, when using Remote SV function.

Flow of input functions

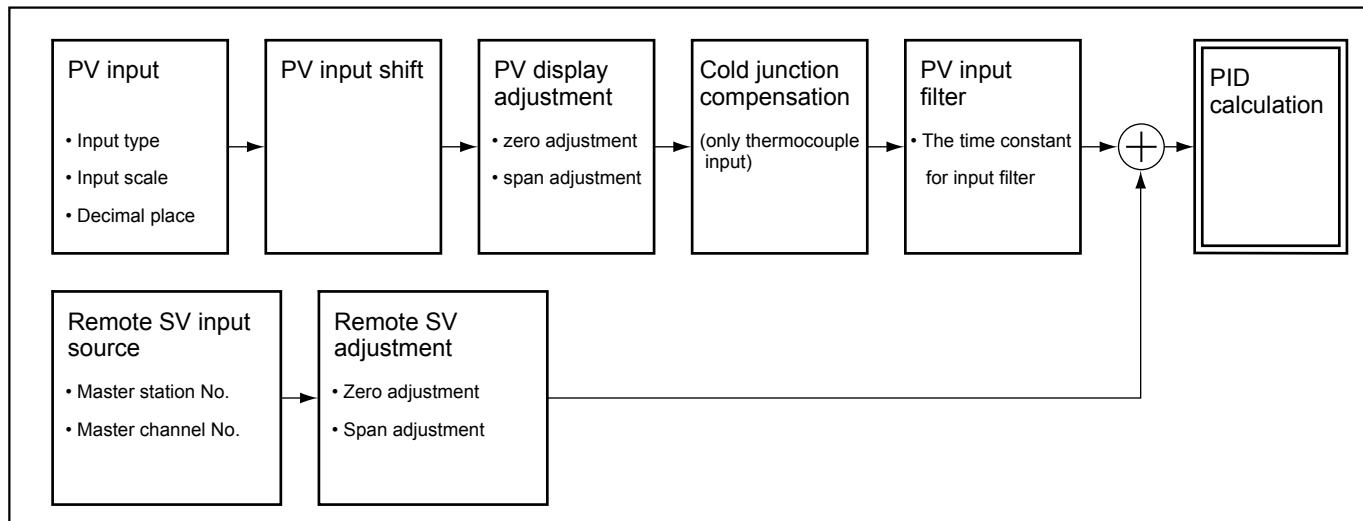

PV Input Basic Setting

Type of PV input signal (Resistance bulb, thermocouple, voltage) has to be set for each channel.

As the type of PV input signal is specified, parameters such as PV input scale lower, PV input scale upper, and decimal place.

Each channel (Ch1 to Ch4) has parameters shown below.

Parameter	Range	Unit	Factory default	Attribute	Modbus register number (relative address)
PV input type	0 to 25	None	7 (Thermocouple/ Resistance bulb input type)	R/W	Ch1: 40151 (0096h) 41029 (0404h)
					Ch2: 40152 (0097h) 42029 (07ECh)
			22 (Voltage input type)		Ch3: 40153 (0098h) 43029 (0BD4h)
					Ch4: 40154 (0099h) 44029 (0FBCh)
PV input scale lower	-1999 to 9999	None	0 (Thermocouple/ Resistance bulb input type)	R/W	Ch1: 41212 (04BBh)
					Ch2: 42212 (08A3h)
			0.0 (Voltage input type)		Ch3: 43212 (0C8Bh)
					Ch4: 44212 (1073h)
PV input scale upper	-1999 to 9999	None	400 (Thermocouple/ Resistance bulb input type)	R/W	Ch1: 41213 (04BCh)
					Ch2: 42213 (08A4h)
			100.0 (Voltage input type)		Ch3: 43213 (0C8Ch)
					Ch4: 44213 (1074h)
Decimal place	0 to 2	None	0 (Thermocouple/ Resistance bulb input type)	R/W	Ch1: 41214 (04BDh)
					Ch2: 42214 (08A5h)
			1 (Voltage input type)		Ch3: 43214 (0C8Dh)
					Ch4: 44214 (1075h)

Measurement range and decimal place limit according to the input type code

Input type		Setting code	Measurement range		Decimal place	
			[degree C]	[degree F]	[degree C]	[degree F]
Resistance bulb	JPT100Ω	0	0 to 150	32 to 302	1	1
		1	-150 to 600	-238 to 1112	1	0
	Pt100Ω	2	0 to 150	32 to 302	1	1
		3	-150 to 300	-238 to 572	1	1
		4	-150 to 850	-238 to 1562	1	0
Thermocouple	J	5	0 to 400	32 to 752	1	1
		6	0 to 800	32 to 1472	1	0
	K	7	0 to 400	32 to 752	1	1
		8	0 to 800	32 to 1472	1	0
		9	0 to 1200	32 to 2192	0	0
	R	10	0 to 1600	32 to 2912	0	0
	B	11	0 to 1800	32 to 3272	0	0
	S	12	0 to 1600	32 to 2912	0	0
	T	13	-199 to 400	-326 to 752	1	0
	E	14	-199 to 800	-326 to 1472	1	0
	N	18	0 to 1300	32 to 2372	0	0
PL-II	19	0 to 1300	32 to 2372	0	0	
DC voltage	DC0-5V	21	-1999 to 9999 (scaling range)		2	2
	DC1-5V	22			2	2
	DC0-10V	23			2	2
	DC2-10V	24			2	2

When the input type has been changed, the measurement range will be re-written. Meanwhile, the decimal place will remain unchanged if it is within the limit of the new input type. If it is over the limit, the upper limit of the new input type will be automatically set. If the decimal place has to be changed, change the setting of "Decimal place" to a new value.

Note

- When PV input type is resistance bulb or thermocouple, input range cannot be changed.
- When PV input type is voltage, make sure to set input range.
- Note that there may be a sudden change in input value at the moment input type has been changed.
- When the range of PV input scale lower and upper has been set to 10000 or over, the operation mode will switch to standby.

Note

Normally, PV input signal is input as a value without decimal place. Set the decimal place if necessary within the setting limit.

Ex) Handle the value "400" as "400.0" to control values to one decimal place.

-> Set the decimal place at "1"

Overrange and underrange

PV input signal also has $\pm 5\%$ of allowable measurement range besides the lower and upper range.

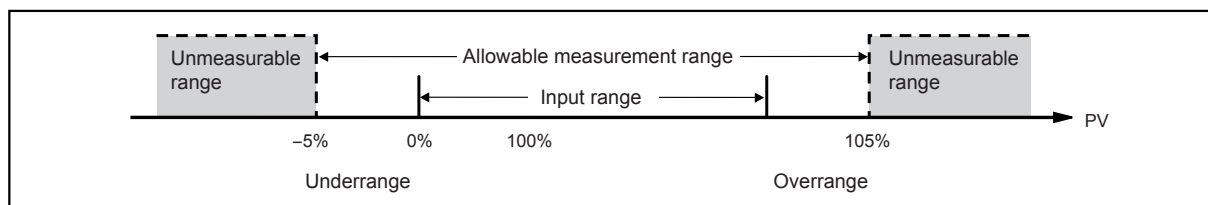

PV Input Filter Setting

Set the input filter damping of low-pass filter, which reduces noise and signal waver.

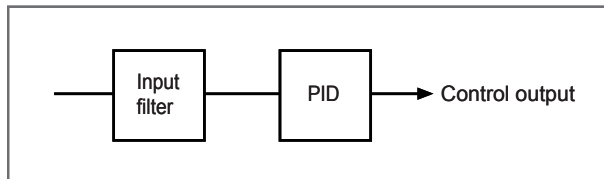

Each channel (Ch1 to Ch4) has parameters shown below.

Parameter	Range	Unit	Factory default	Attribute	Modbus register number (relative address)
PV input filter	0.0 to 120.0	Sec.	2.0	R/W	Ch1: 41220 (04C3h)
					Ch2: 42220 (08ABh)
					Ch3: 43220 (0C93h)
					Ch4: 44220 (107Bh)

Set the number of seconds which PV input signal takes to change to 63.2%.

For example, when the input suddenly steps from 0% to 100% with the input filter constant set to 5 seconds, the PV value will change from 0% to 63.2% in 5 seconds in a gentle curve.

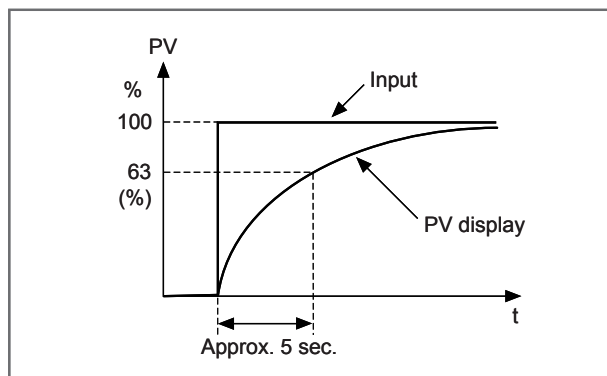

PV Input Shift Setting

Sets the shift amount in order to adjust the PV value before it is displayed.

Each channel (Ch1 to Ch4) has parameters shown below.

Parameter	Range	Unit	Factory default	Attribute	Modbus register number (relative address)
PV input shift	-10 to 10	%FS	0	R/W	Ch1: 41216 (04BFh)
					Ch2: 42216 (08A7h)
					Ch3: 43216 (0C8Fh)
					Ch4: 44216 (1077h)

This is used when combining PV input with other instruments.

For example, to shift PV -5°C , set the value of "PV input shift" to "-5"
 PV display will be the value after -5°C shift as shown in the right figure.

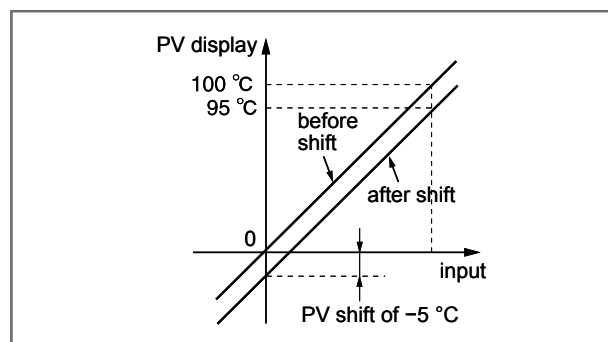

PV Display Zero & Span Adjustment Setting

Sets the shift amount in order to adjust PV display zero and span. The shift amount should be the actual difference value with the opposite sign.

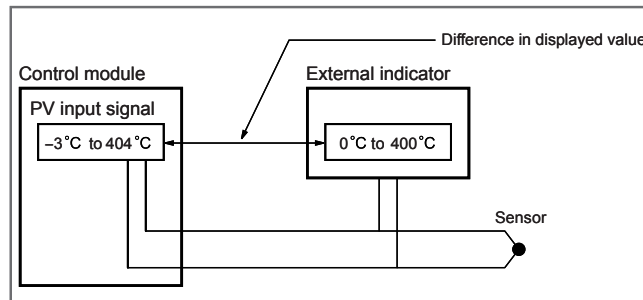

Each channel (Ch1 to Ch4) has parameters shown below.

Parameter	Range	Unit	Factory default	Attribute	Modbus register number (relative address)
PV display zero adjustment	-50 to 50	%FS	0	R/W	Ch1: 41221 (04C4h)
					Ch2: 42221 (08ACh)
					Ch3: 43221 (0C94h)
					Ch4: 44221 (107Ch)
PV display span adjustment	-50 to 50	%FS	0	R/W	Ch1: 41222 (04C5h)
					Ch2: 42222 (08ADh)
					Ch3: 43222 (0C95h)
					Ch4: 44222 (107Dh)

Set the following equipment before using these parameters or starting revisions.

- mV Generator
 - 1V to 5V (for voltage input)
 - 0mV to 100mV (for thermocouple input)
- Dial resistance unit
 - 100.0 to 400.0 Ω (for resistance thermometer bulb input)

Set the difference value which has been caused when 0% PV input signal is sent to “PV display zero adjustment” with the opposite sign, and the difference value caused when 100% PV input signal is sent to “PV display span adjustment” with the opposite sign.

For example, if a zero deviation is -3°C and a span deviation is 4°C , set PV display zero adjustment value to 3°C , and set PV display span adjustment value to -4°C

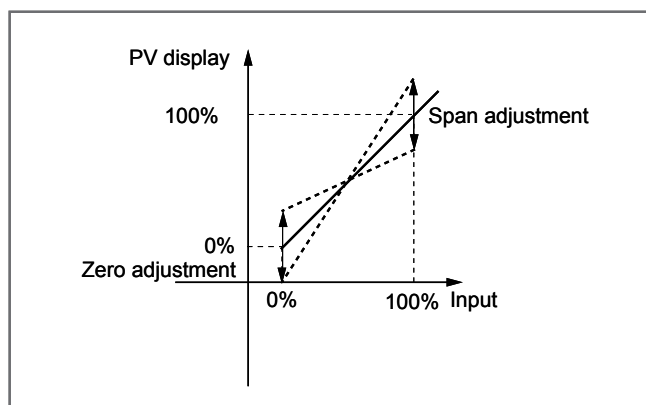

Note

In case of thermocouple input, be sure to set the cold junction compensation  4-21 to OFF before checking the displayed value. Remember to set it back to ON when adjustment is complete.

Point

PV display zero and span adjustment function is independent from the controller adjustment value. Set the value to 0 to restore the factory settings.

Cold Junction Compensation Setting

In case of thermocouple input, decide whether to set turning cold junction compensation to ON or OFF.

Each channel (Ch1 to Ch4) has parameters shown below.

Parameter	Range	Unit	Factory default	Attribute	Modbus register number (relative address)
Cold junction compensation	0: OFF 1: ON	None	1	R/W	Ch1: 41223 (04C6h)
					Ch2: 42223 (08AEh)
					Ch3: 43223 (0C96h)
					Ch4: 44223 (107Eh)

This setting should be "1:ON" during normal operation. Set to "0:OFF" when cold junction compensation is being performed externally, when checking temperature deviation or when cold junction compensation function is not necessary.

Remote SV Input Source Setting RST

Sets the master station No. and master Ch No. of each channel whose settings will be adopted for SV value when using Remote SV function.

Each channel (Ch1 to Ch4) has parameters shown below.

Parameter	Range	Unit	Factory default	Attribute	Modbus register number (relative address)
Remote SV master station No.	0 to 255	None	0	R/W	Ch1: 41532 (05FBh)
					Ch2: 42532 (09E3h)
					Ch3: 43532 (0DCBh)
					Ch4: 44532 (11B3h)
Remote SV master Ch No.	1 to 4	None	an each Ch	R/W	Ch1: 41533 (05FCh)
					Ch2: 42533 (09E4h)
					Ch3: 43533 (0DCCh)
					Ch4: 44533 (11B4h)

In case of using PV input signal of the same module as Remote SV input source.

Set the master station No. to “0” or “the station No. of the module (the No. which station number configuration switch indicates+1)”, set the master Ch No. to “the Ch No. of the input source module”.

In case of using PV input signal of another module as Remote SV input source.

Set the master station No. to “the station No. of the input source module (the No. which station number configuration switch indicates +1)”, set the master Ch No. to “the Ch No. of the input source module”.

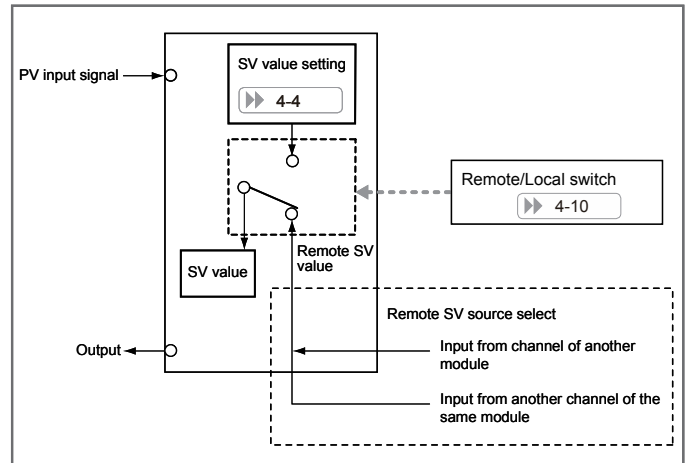

Note

- Remote SV value is limited at the SV lower and upper limit set values. ▶▶ 4-46
- Input error detect function is not available for Remote SV input.
- Remote SV value will be always “0”, if the input source is the station and Ch No. on which the setting is being done.
- In case DI master station No. , output master station No and linkage operation master station No. have been also set as well as Remote SV master station No., the red lamp of PWR LED will be illuminated (system FAULT) if none of the station numbers exist. PWR LED lamp will not be illuminated if any of the station numbers exists.

Remote SV Zero and Span Adjustment

Sets the shift amount to adjust the zero and span position.

Each channel (Ch1 to Ch4) has parameters shown below.

Parameter	Range	Unit	Factory default	Attribute	Modbus register number (relative address)
RSV zero adjustment	-50 to 50	%FS	0	R/W	Ch1: 41225 (04C8h)
					Ch2: 42225 (08B0h)
					Ch3: 43225 (0C98h)
					Ch4: 44225 (1080h)
RSV span adjustment	-50 to 50	%FS	0	R/W	Ch1: 41226 (04C9h)
					Ch2: 42226 (08B1h)
					Ch3: 43226 (0C99h)
					Ch4: 44226 (1081h)

This setting is made when further adjustment of PV input value used as Remote SV input is required.

See how the zero and span position are adjusted from Remote SV input value as shown in the right figure.

Set the shift amount of "Remote SV zero adjustment" to the value required when input is 0%. Set the shift amount of "Remote SV span adjustment" to the value required when input is 100%.

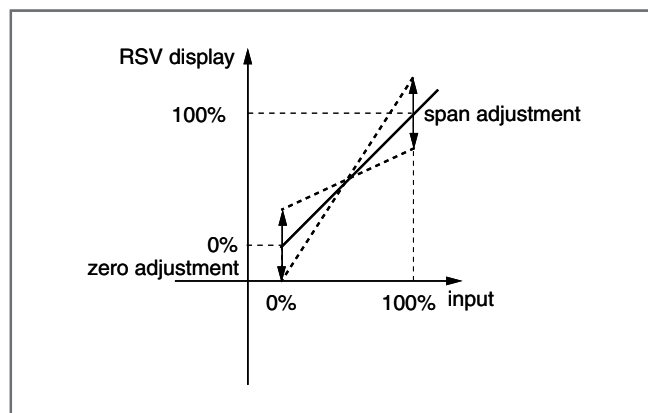

Example)

Remote SV input source : Ch 3 (input cord "22", voltage input 1 to 5V)

Remote SV is applied to : Ch1

Before adjustment)

When Ch input is 0%, Remote SV value deviation is +5°C.

When Ch input is 100%, Remote SV value deviation is -15°C.

Adjustment procedure)

Input the following values to set the shift amount.

Ch1 RSV zero adjustment : -5

Ch1 RSV span adjustment : +15

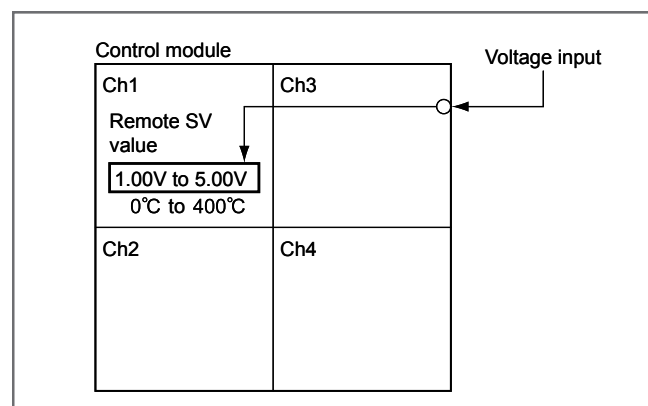

4.3 Output Setting

Output Setting

Output type differs depending on the model type being used.

The icons shown below appear beside the relative setting items.

- Relay output type, SSR drive output type..... **RELAY/SSR**
- Current output type **CURRENT**

Before using this module, make sure to complete necessary settings according to the model type used.

Also, parameters reset the main unit is necessary when changing the setting is marked in each setting explanation **(RST)**.

Note

The output signal which different from the type being used cannot be output.

Output setting for relay output and SSR drive output type

- Output proportion cycle setting **▶▶ 4-26**
- Output source setting **▶▶ 4-28**
- Output scaling base and span setting **▶▶ 4-31**
- Output shutdown setting **▶▶ 4-32**

Output setting for current output type

- Current output range setting **▶▶ 4-27**
- Output source setting **▶▶ 4-28**
- Output scaling base and span setting **▶▶ 4-31**
- Output shutdown setting **▶▶ 4-32**

Flow of output functions

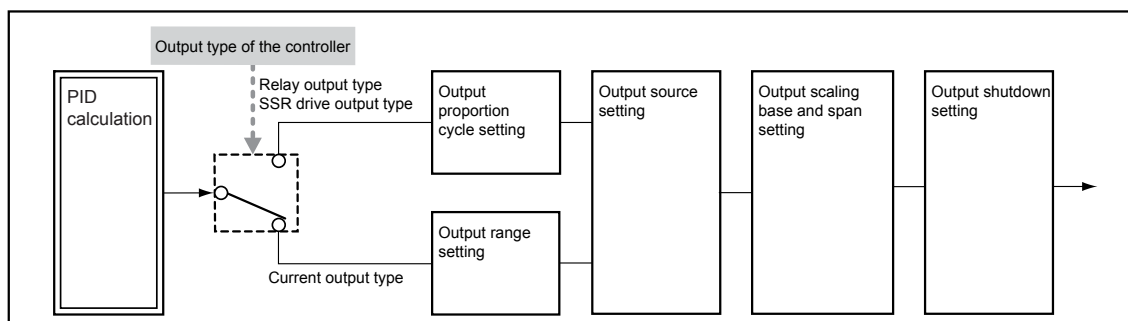

Output Proportional Cycle Setting

RELAY/SSR

Sets the proportional cycle of Relay output and SSR drive output.

Point

When using relay output and SSR drive output, output will switch ON/OFF at regular intervals. These intervals are called proportional cycles.

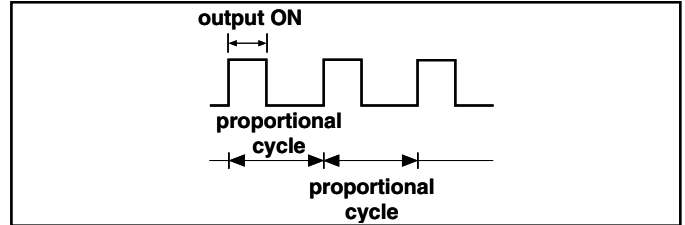

Each output channel (Ch1 to Ch4) has parameters shown below.

Parameter	Range	Unit	Factory default	Attribute	Modbus register number (relative address)
Output proportional cycle	1 to 120	Sec.	30 (Relay output type)	R/W	Ch1: 40176(00AFh)
					Ch2: 40182(00B5h)
			2 (SSR drive output type)		Ch3: 40188(00BBh)
					Ch4: 40194(00C1h)

Recommended settings as shown below.

Relay output	The shorter the proportional cycle, the finer the control, however shorter proportional cycles also shorten the lifespan of the contact points and operating device. Be sure to balance control and controller lifespan when adjusting the proportional cycles. Approx: 30 sec.
SSR drive output	Because there are no mechanical parts to this controller, use a short proportional cycle if the operating device is working properly. Approx: 1 sec. to 2 sec.

Note

- When current output is used, these settings are ignored.
- To synchronize each channel after changing output proportional setting, be sure to reset the module.

Current Output Range Setting

CURRENT

Set the output range when current output is used.

Each output channel (Ch1 to Ch4) has parameters shown below.

Parameter	Range	Unit	Factory default	Attribute	Modbus register number (relative address)
Current output range	4 (0 to 20mA) 5 (4 to 20mA)	None	5	R/W	Ch1: 40166 (00A5h) 41801 (0708h)
					Ch2: 40167 (00A6h) 42801 (0AF0h)
					Ch3: 40168 (00A7h) 43801 (0ED8h)
					Ch4: 40169 (00A8h) 44801 (12C0h)

Current output range differs according to the set value as follows;

Set value	0% output	100% output
4	0mA	20mA
5	4mA	20mA

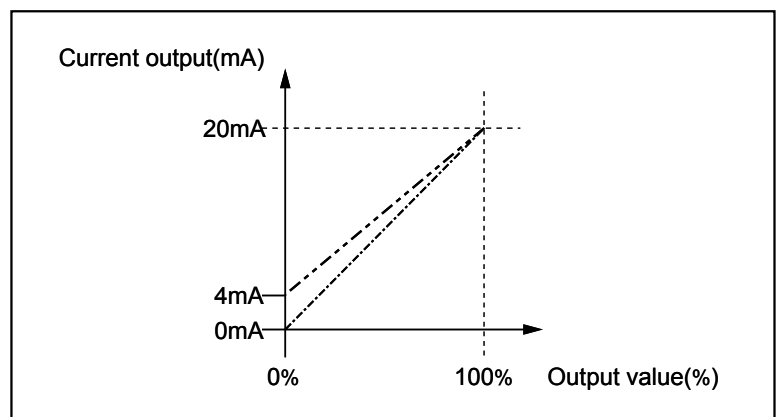

Note

When relay output or SSR drive output is used, this setting is ignored.

Output Source Setting

RST

RELAY/SSR

CURRENT

Sets the master station No., master Ch No., and output type for each output channel.

Each output channel (Ch1 to Ch4) has parameters shown below.

Parameter	Range	Unit	Factory default	Attribute	Modbus register number (relative address)
Output master Station No.	0 to 255	None	0	R/W	Ch1: 40172 (00ABh) 41804 (070Bh)
					Ch2: 40178 (00B1h) 42804 (0AF3h)
					Ch3: 40184 (00B7h) 43804 (0EDBh)
					Ch4: 40190 (00BDh) 44804 (12C3h)
Output master Ch No.	1 to 4	None	1 to 4 (Ch No. of the module being set)	R/W	Ch1: 40173 (00ACh) 41805 (070Ch)
					Ch2: 40179 (00B2h) 42805 (0AF4h)
					Ch3: 40185 (00B8h) 43805 (0EDCh)
					Ch4: 40191 (00BEh) 44805 (12C4h)
Output type	0 to 7	None	3 (MV1 of the module being set)	R/W	Ch1: 40171 (00AAh) 41803 (070Ah)
					Ch2: 40177 (00B0h) 42803 (0AF2h)
					Ch3: 40183 (00B6h) 43803 (0EDAh)
					Ch4: 40189 (00BCh) 44803 (12C2h)

Image of output source setting (for output Ch1)

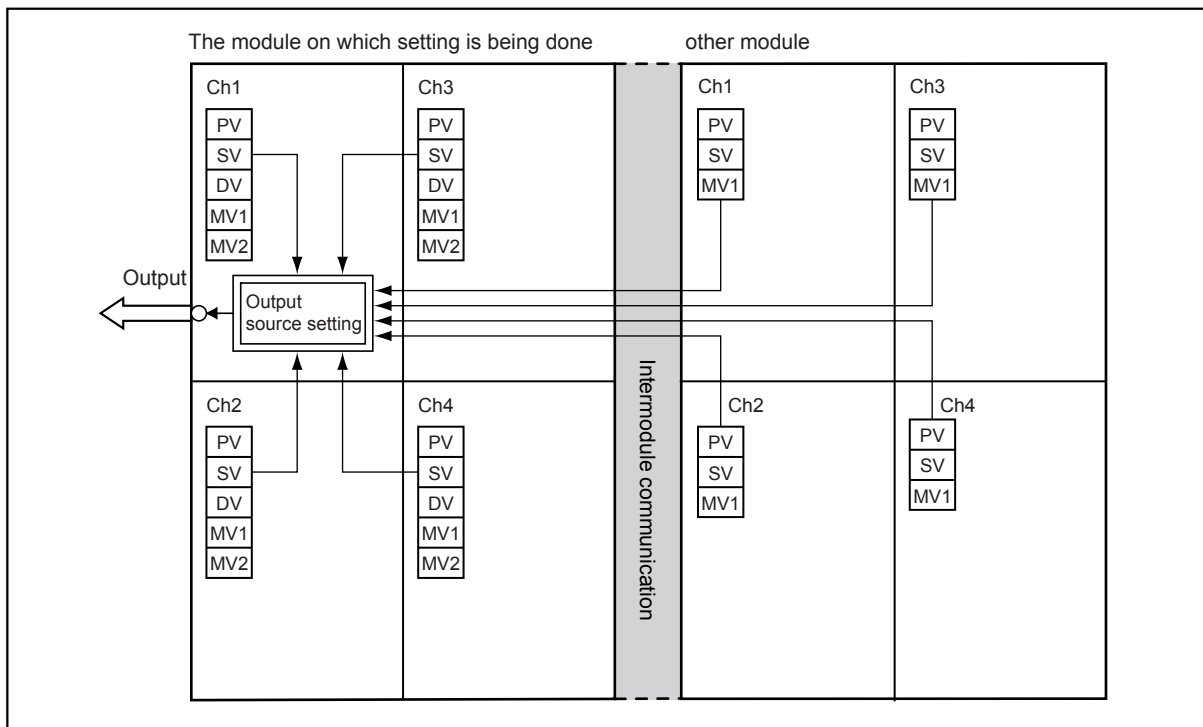

Setting output master station and output master Ch

- When using values of the same module

Set the output master station No. to "0" or the station No. of the module being set. Set the output master Ch No. to the Ch No. which has the values to be used.

- When using values of another module

Set the output master station No. to the station No. (station number configuration switch No. + 1) of the output source + 1.
Set the output master Ch No. to Ch No. of the output master station which has the values to be used.

Output type setting

Types of values which can be used as output values are as shown in the right figure.

Set value	Output values	
0	Own module	PV
1		SV
2		DV
3		MV1 (heating output)
4		MV2 (cooling output)
5	Other modules	PV
6		SV
7		MV1 (heating output)

Note

- When the value of the module on which setting is being done is selected, the setting of master station No. will be ignored. The module being set will be automatically selected.
- If the module is a relay output or SSR drive output model, only MV values (3,4,7) can be selected for the output type.
- MV2, or DV of another module cannot be output. When output of MV2 and DV is necessary, select them as for "Output type" of another channel of the same module.
- In case Remote SV master station No. , DI master station No. and linkage operation master station No. have been also set as well as output master station No., the red lamp of PWR LED will be illuminated (system FAULT) if none of the station numbers exist. PWR LED lamp will not be illuminated if any of the station numbers exists.

Output Scaling Base and Span Setting

RELAY/SSR

CURRENT

Sets the amount which the output scaling base and span should shift to adjust output signal.

Each output channel (Ch1 to Ch4) has parameters shown below.

Parameter	Range	Unit	Factory default	Attribute	Modbus register number (relative address)
Output scaling base	-100.0 to 100.0	%	0	R/W	Ch1: 40175 (00AEh) 41807 (070Eh)
					Ch2: 40181 (00B4h) 42807 (0AF6h)
					Ch3: 40187 (00BAh) 43807 (0EDEh)
					Ch4: 40193 (00C0h) 44807 (12C6h)
Output scaling span	-100.0 to 100.0	%	100	R/W	Ch1: 40174 (00ADh) 41806 (070Dh)
					Ch2: 40180 (00B3h) 42806 (0AF5h)
					Ch3: 40186 (00B9h) 43806 (0EDDh)
					Ch4: 40192 (00BFh) 44806 (12C5h)

If the value to be output is equal to or lower than the value set to the output scaling base, output will be 0%.

If the value to be output is equal to or higher than the value set to the output scaling span, output will be 100%

For example, to change the output scaling to 20% to 80%, by setting the output scaling base to "20" and the output scaling span to "80", 20% to 80% of values to be output will be 0% to 100% output.

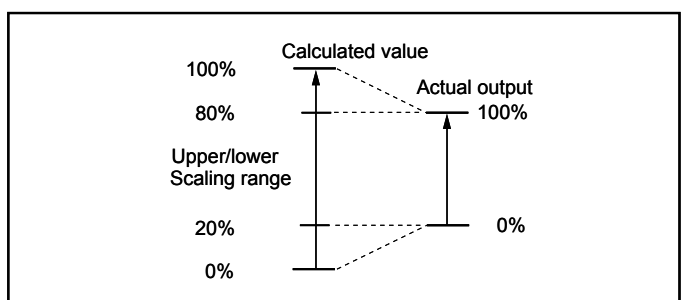

Note

Make sure that output scaling base set value is smaller than output scaling span set value.

Output Shutdown Setting

RELAY/SSR

CURRENT

Sets the Ch No. of own station to stop output.

Parameter	Range	Unit	Factory default	Attribute	Modbus register number (relative address)
Output shutdown	0 to 15 (0000 to 11111)	None	0(0000b)	R/W	40201(00C8h)

Output shutdown setting for each Ch

Set "1" to each bit No. corresponding to each channel to stop output.

Set value	Ch No. to stop output				Ch1	Ch2	Ch3	Ch4
	bit3 (Ch4)	bit2 (Ch3)	bit1 (Ch2)	bit0 (Ch1)				
0	0	0	0	0				
1	0	0	0	1	○			
2	0	0	1	0		○		
3	0	0	1	1	○	○		
4	0	1	0	0			○	
5	0	1	0	1	○		○	
6	0	1	1	0		○	○	
7	0	1	1	1	○	○	○	
8	1	0	0	0				○
9	1	0	0	1	○			○
10	1	0	1	0		○		○
11	1	0	1	1	○	○		○
12	1	1	0	0			○	○
13	1	1	0	1	○		○	○
14	1	1	1	0		○	○	○
15	1	1	1	1	○	○	○	○

Note

Bit numbers and Ch number are in reverse order.

Point

Output shutdown also can be performed by digital input from even input/output module. Refer to the section "Digital input function setting" [▶▶ 4-88](#) " in "4-7 Optional functions setting".

4.4 Control Setting

Control Setting

Control method can be selected from the following four types.

ON/OFF (2 position) control	Control output switches ON and OFF according to magnitude relationship between PV and SV. Control system can be established using simple elements such as solid stay relay. Suitable where low degree of accuracy is required.
PID control	PID calculation and controls proceed according to the previously set PID parameters. PID parameters can be set manually or through Auto-tuning (AT). It is the most basic control in this equipment.
FUZZY PID control	Reduces the amount of overshoot during control. It is effective when you want to suppress overshoot while changing SV, even during processes where it may take a long time to reach the target value.
PID control against open-loop	Suppresses the amount of overshoot during control for processes that turn the control target off and then on again. It is effective when the control target turns on and off while power flows continuously to the temperature controller.

Control type setting

- Control algorithm select [▶▶ 4-34](#)

Control parameter setting

- Proportional band[P], Integration time[I], Derivative time[D] setting [▶▶ 4-37](#)
- Anti-reset windup setting [▶▶ 4-39](#)
- ON/OFF control hysteresis setting [▶▶ 4-40](#)
- ON/OFF hysteresis setting [▶▶ 4-41](#)
- Direct/reverse action setting [▶▶ 4-42](#)
- Cooling proportional band coefficient [▶▶ 4-43](#)
- Dead band setting [▶▶ 4-44](#)
- Output convergence value setting [▶▶ 4-45](#)

Target value setting

- SV lower and upper limits setting [▶▶ 4-46](#)
- SV Offset [▶▶ 4-47](#)
- Ramp SV setting [▶▶ 4-48](#)

Output control setting

- Control output limiter type setting [▶▶ 4-49](#)
- Standby MV setting [▶▶ 4-51](#)
- Soft start setting [▶▶ 4-52](#)
- Operation setting when input error occurred [▶▶ 4-53](#)

Operational control setting

- Start up mode setting [▶▶ 4-54](#)

Control Algorithm Select

Sets the control mode.

Each channel (Ch1 to Ch4) has parameters shown below.

Parameter	Range	Unit	Factory default	Attribute	Modbus register number (relative address)
Proportional band[P] (*1)	0.0 to 999.9 0.0 : ON/OFF control Other than 0.0 : varies depending on type of control algorithm	%	5.0	R/W	Ch1: 41102 (044Dh)
					Ch2: 42102 (0835h)
					Ch3: 43102 (0C1Dh)
					Ch4: 44102 (1005h)
Control algorithm (*2)	0 : PID control 1 : FUZZY PID control 2 : PID control against open-loop	None	0	R/W	Ch1: 41291 (050Ah)
					Ch2: 42291 (08F2h)
					Ch3: 43291 (0CDAh)
					Ch4: 44291 (10C2h)

*1 Setting for control mode is explained here. For over all proportional band setting, refer to “Proportional band[P], Integration time[I], Derivative time[D] setting”  **4-37**

*2 This setting will be valid when Proportional band[P] has been set to values other than “0.0”.

ON/OFF (2 position) control

Operates when Proportional band[P] is set to 0.0. [▶▶ 4-37](#) ON/OFF control switches the control output to ON (100%) or OFF (0%) according to the SV/PV magnitude relationship. For setting output hysteresis, refer to “ON/OFF control hysteresis setting” [▶▶ 4-40](#) , and “ON/OFF hysteresis setting” [▶▶ 4-41](#)

– Reverse Operation (Heating)

Method used to control the electrical heating furnace. As the PV input signal increases, control output decreases or turns OFF. Set the hysteresis to an appropriate value according to the control target.

Parameter	Set value
Proportional band[P] ▶▶ 4-37	0.0
Direct/Reverse action ▶▶ 4-42	Heating(reverse) / Cooling(None)
ON/OFF control hysteresis ▶▶ 4-40	Optional

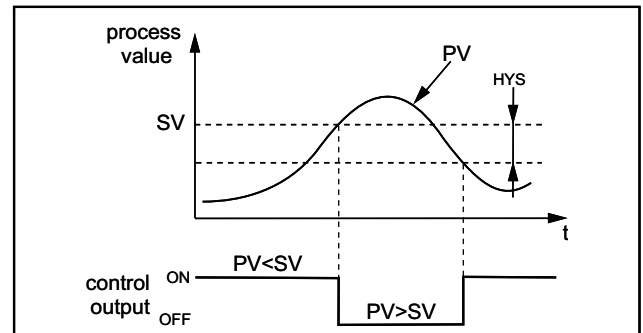

– Direct Operation (Cooling)

Method used to control the cooling machine. As the PV input signal increases, control output increases or turns ON. Set the hysteresis to an appropriate value according to the control target.

Parameter	Set value
Proportional band[P] ▶▶ 4-37	0.0
Direct/Reverse action ▶▶ 4-42	Heating(direct) / Cooling(None)
ON/OFF control hysteresis ▶▶ 4-40	Optional

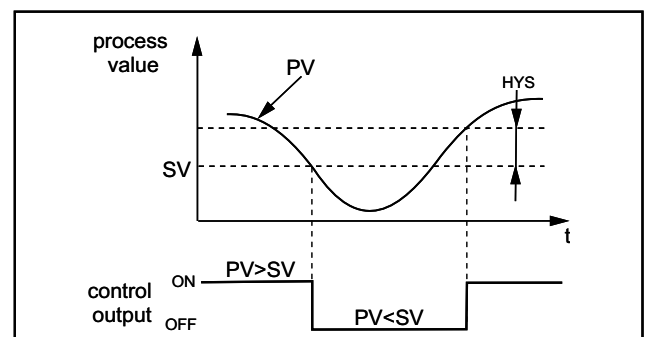

Note

- During ON/OFF control, Integration[I] and Derivative[D] settings do not affect control. [▶▶ 4-37](#)
- If the hysteresis width is narrow, and PV and SV are nearly equal, the output may frequently switch ON and OFF. Note that doing so may affect the operation life of the relay contact output.

PID control

Operates when the control algorithm is set to "0:PID control" and Proportional band[P] $\neq 0.0$. [▶▶ 4-37](#) In PID control, values which have been calculated based on the set values of Proportional band[P], Integration time[I], Derivative time[D] [▶▶ 4-37](#), and anti-reset windup [▶▶ 4-39](#) are output.

Point

Optimal values for each parameter will be set by running Auto-tuning. [▶▶ 4-6](#)

FUZZY PID control

Operates when the control algorithm is set to "1: FUZZY PID control". This control minimizes the overshoot compared to normal PID.

Fuzzy PID control can only be used after Auto-tuning [▶▶ 4-6](#) has been activated to set Proportional band[P], Integration time[I], Derivative time[D] [▶▶ 4-37](#), and anti-reset windup. [▶▶ 4-39](#)

PID control against open-loop

Operates when the control algorithm is set to "2: PID control against open-loop". This control reduces overshoot during control for the processes that turns the controlled equipments ON, OFF, and ON again. The algorithm adopted prevents overintegration of the PID calculations even while the control loop is open.

PID control against open-loop can only be used after Auto-tuning [▶▶ 4-6](#) has been activated to set Proportional band[P], Integration time[I], Derivative time[D] [▶▶ 4-37](#), and anti-reset windup. [▶▶ 4-39](#)

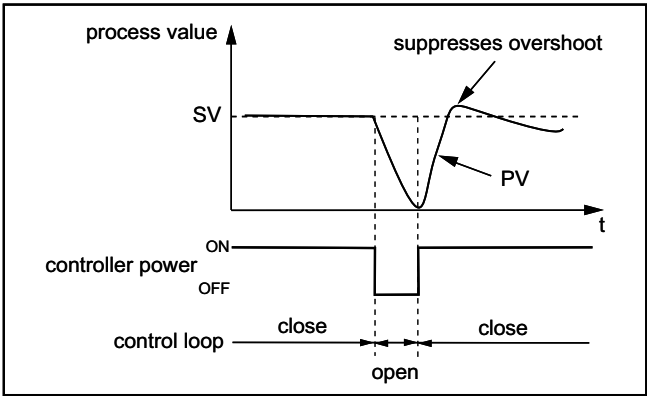

Proportional Band (P), Integration Time (I), Derivative Time (D) Setting

Set the parameters for PID control. Running Auto-tuning will automatically set optimal value for each parameter. [▶▶ 4-6](#)

Each channel (Ch1 to Ch4) has parameters shown below.

Parameter	Range	Unit	Factory default	Attribute	Modbus register number (relative address)
Proportional band [P]	0.0 to 999.9 (*1)	%	5.0	R/W	Ch1: 41102 (044Dh)
					Ch2: 42102 (0835h)
					Ch3: 43102 (0C1Dh)
					Ch4: 44102 (1005h)
Integration time [I]	0 to 3200 (*2)	Sec.	240	R/W	Ch1: 41103 (044Eh)
					Ch2: 42103 (0836h)
					Ch3: 43103 (0C1Eh)
					Ch4: 44103 (1006h)
Derivative time [D]	0.0 to 999.9 (*3)	Sec.	60.0	R/W	Ch1: 41104 (044Fh)
					Ch2: 42104 (0837h)
					Ch3: 43104 (0C1Fh)
					Ch4: 44104 (1007h)

*1 Setting for PID control is explained here. For ON/OFF control action setting, refer to "Control algorithm select" [▶▶ 4-34](#)
In case of heating/cooling control, cooling proportional band will be set.

*2 Setting "Integration time[I]" to 0 will stops integral control.

*3 Setting "Derivative time[D]" to 0.0 will stops derivative control.

Following control method can be selected by setting parameters.

ON/OFF (2 position) control	When PID parameter P = 0.0, ON/OFF control is used, regardless of the values for I and D. Use this function when you want to add simple controls without worrying about the controllability. ▶▶ 4-34
PID control	Use this function when you want to control with high controllability. Operates when P ≠ 0.0, I ≠ 0, and D ≠ 0.0, but P, I, and D must be adjusted to optimal values for the control target. In normal situations, run Auto-tuning to optimally adjust P, I, and D before using this function. See "Running auto-tuning". ▶▶ 4-6
PI control	When P ≠ 0.0, I ≠ 0, and D = 0.0, D control is turned off and PI control is used.
P control	When P ≠ 0.0, I = 0, and D = 0.0, I and D controls are turned off and P control is used. In principle, P control generates offset and PV does not always equal SV. In this situation, adjust the amount of offset by setting "Output convergence value". See "Output convergence value setting". ▶▶ 4-45

Note

Please do not run Auto-tuning [▶▶ 4-6](#) when ON/OFF (2 position) control is selected. Running Auto-tuning change Proportional band from 0.0 and ON/OFF control will not operate.

Proportional control action

Proportional control action outputs the value proportion to the deviation between PV and SV.

When P is small, it takes less time to reach SV and to stabilize, however, hunching and overshoot may result.

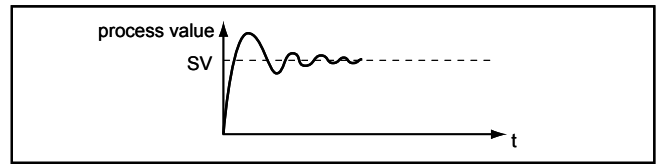

When P is big, it takes more time to reach SV and to stabilize, however, hunching and overshoot can be suppressed.

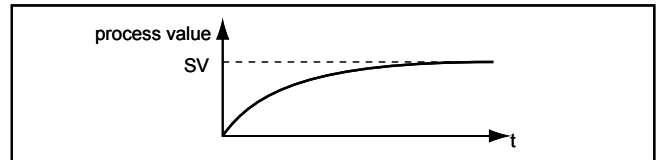

Integral control action

Integral control action eliminates offset caused by the proportional control action.

When I is small, it takes less time to reach SV and to stabilize, however, overshoot/undershoot, and hunching may result.

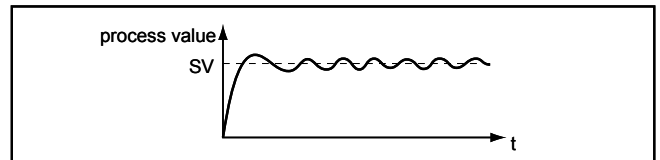

When I is big, it takes more time to reach SV and to stabilize, however, overshoot/undershoot and hunching can be suppressed.

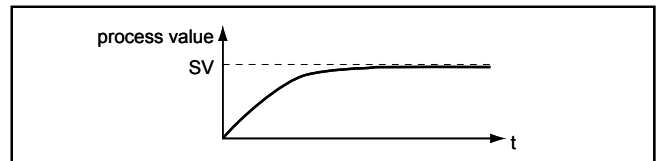

Derivative control action

Derivative control action suppresses hunching caused by proportional control action and integral control action.

When D is small, it takes more time to reach SV and to stabilize, however, hunching can be suppressed.

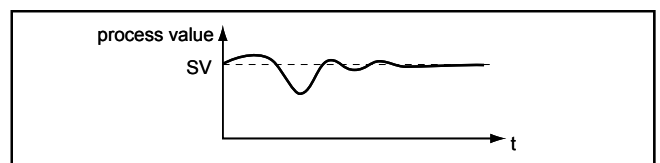

When D is big, it takes less time to reach SV and to stabilize, however, hunching may result.

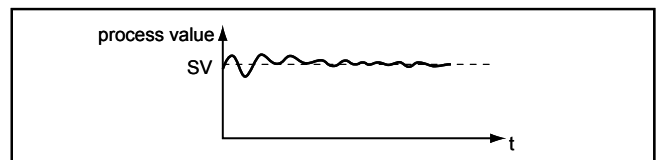

Anti-reset Windup Setting

Anti-reset windup is a function that limits the range of valid integration. Running Auto-tuning will automatically set the optimal value. [▶▶ 4-6](#)

Each channel (Ch1 to Ch4) has parameters shown below.

Parameter	Range	Unit	Factory default	Attribute	Modbus register number (relative address)
Anti-reset windup	0 to 100	%FS	100	R/W	Ch1: 41109 (0454h)
					Ch2: 42109 (083Ch)
					Ch3: 43109 (0C24h)
					Ch4: 44109 (100Ch)

By limiting the range of valid integration, it suppresses overshoot resulted from excessive integral control action.

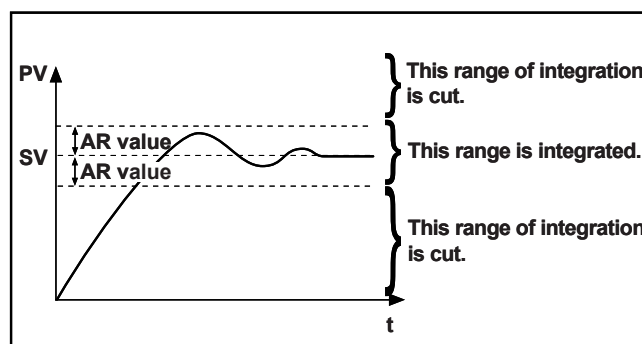

Point

This module implements fuzzy control. If "FUZZY PID control" is selected [▶▶ 4-34](#), overshoot can be minimized without using anti-reset windup function.

ON/OFF Control Hysteresis Setting

Sets the hysteresis for control output during ON/OFF (2 position) control.

When heating/cooling control is selected and both heating and cooling outputs have been set to ON/OFF actions (3 positions control), hysteresis will be set to heating(reverse) output. [▶▶ 4-42](#)

Each channel (Ch1 to Ch4) has parameters shown below.

Parameter	Range	Unit	Factory default	Attribute	Modbus register number (relative address)
ON/OFF control hysteresis	0.0 to 50.0	%FS	0.25(*1)	R/W	Ch1: 41105 (0450h)
					Ch2: 42105 (0838h)
					Ch3: 43105 (0C20h)
					Ch4: 44105 (1008h)

*1 If the input type is 7(K:0 to 400 degrees C), the value is 1°C. [▶▶ 4-15](#)

Controllability depending on the size of the hysteresis

Small hysteresis	<ul style="list-style-type: none"> • High-precision control • Frequency of output relays is high, so lifespan is short
Large hysteresis	<ul style="list-style-type: none"> • Low-precision control • Frequency of output relays is low, so lifespan is long

The relationship between SV and hysteresis in direct and reverse actions is shown below.

– Reverse action

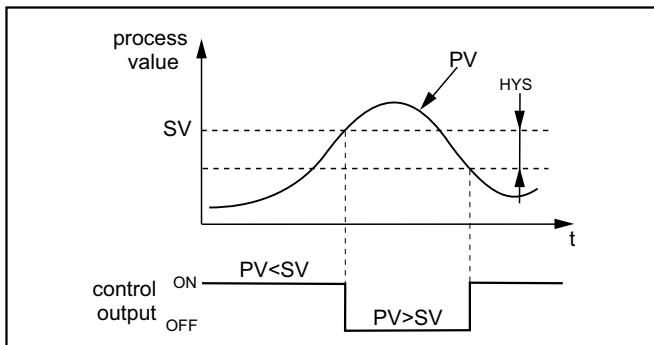

– Direct action

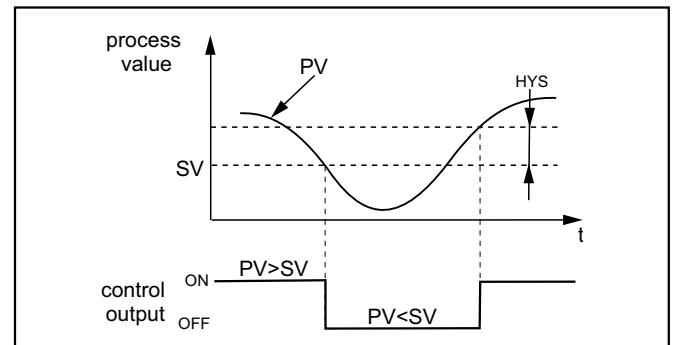

Note

If the hysteresis width is narrow, and PV and SV are nearly equal, the output may frequently switch ON and OFF. Note that doing so may affect the operation life of the contact output.

Action of hysteresis which has been set is specified on “Hysteresis action setting”. [▶▶ 4-41](#)

ON/OFF Hysteresis Setting

Specifies the hysteresis mode during ON/OFF (2 position) control.

Each channel (Ch1 to Ch4) has parameters shown below.

Parameter	Range	Unit	Factory default	Attribute	Modbus register number (relative address)
ON/OFF hysteresis setting	0 : OFF 1 : ON	None	1(ON)	R/W	Ch1: 41292 (045Bh)
					Ch2: 42292 (08F3h)
					Ch3: 43292 (0CDBh)
					Ch4: 44292 (10C3h)

OFF: Performs two position control at $SV+HYS/2$ and $SV-HYS/2$.

ON: Performs two position control at SV , $SV+HYS$ and SV , $SVHYS$.

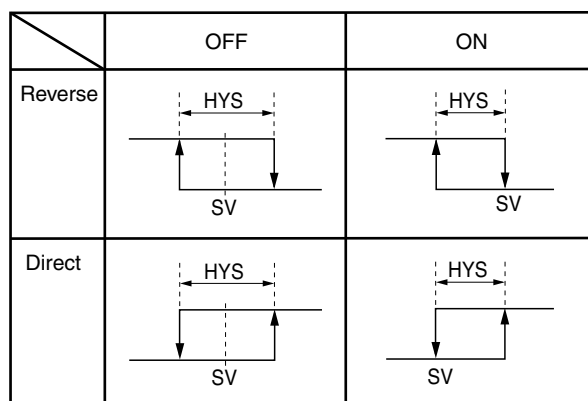

Also refer to "ON/OFF control hysteresis setting" [▶▶ 4-40](#)

Direct/Reverse Action Setting

Specifies whether the control operation is direct or reverse, single or dual (heating/cooling).

Each channel (Ch1 to Ch4) has parameters shown below.

Parameter	Range	Unit	Factory default	Attribute	Modbus register number (relative address)
Direct/Reverse setting [MV1/MV2]	0 to 5	None	0	R/W	Ch1: 41110 (0455h)
					Ch2: 42110 (083Dh)
					Ch3: 43110 (0C25h)
					Ch4: 44110 (100Dh)

Direct/Reverse set values

Refer to the table below specifying the set value.

Set value	Operation mode	MV1(heat output)	MV2 (cool output)
0	Single control	Reverse	None
1		Direct	None
2	Dual control (heating/cooling control)	Reverse	Direct
3		Direct	Reverse
4		Reverse	Reverse
5		Direct	Direct

In most heating/cooling control, control is done with MV1 (heating) in reverse action and MV2 (cooling) in direct action.

– Reverse action

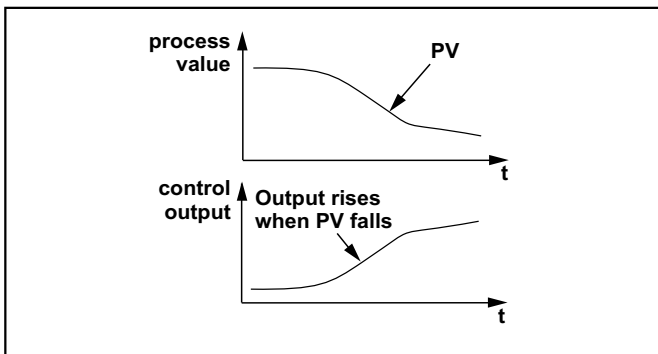

– Direct action

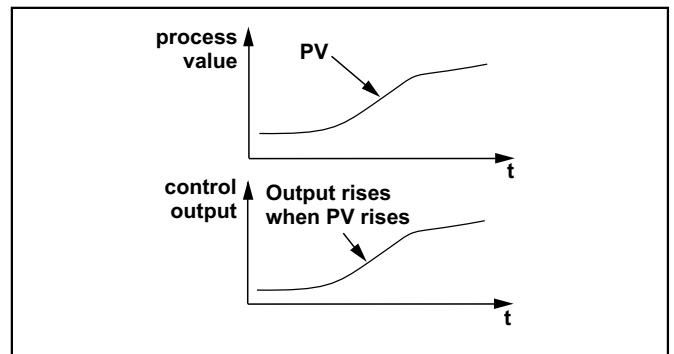

Note

- To perform heating/cooling control operation, be sure to set the output convergence value to 50%. [▶▶ 4-45](#)
- When using heating/cooling operation in heating/cooling control, cool output always outputs from MV2.

Cooling Proportional Band Coefficient Setting

Sets Cooling proportional band coefficient.

Note

This setting is valid when heating/cooling control are set. [▶▶ 4-42](#)

Cooling proportional band is set after the optimal value for Heating proportional band [▶▶ 4-37](#) is set.

Each channel (Ch1 to Ch4) has parameters shown below.

Parameter	Range	Unit	Factory default	Attribute	Modbus register number (relative address)
Cooling proportional band [cool]	0.0 to 100.0	None	1.0	R/W	Ch1: 41106 (0451h)
					Ch2: 42106 (0839h)
					Ch3: 43106 (0C21h)
					Ch4: 44106 (1009h)

The relationship between heating control output and cooling control output is outlined below.

Specify the cooling proportional band when the same coefficient cannot control heating and cooling equally because of the characteristic difference. Set the value so that the heating and cooling output will be balanced.

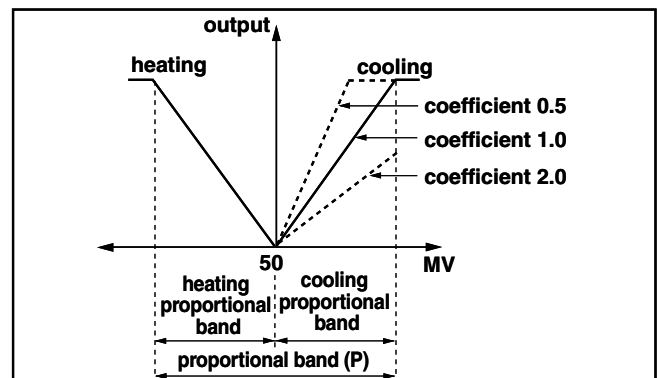

Cooling proportional band can be calculated using the formula below.

$$\text{Cooling proportional band} = (\text{Heating proportional band}/2) \times \text{Cooling proportional band coefficient}$$

For example,

What is the coefficient that will give a cooling proportional band of 10% when heating proportional band = 50% with full scale.

$$10\%FS = (50\%/2) \times \text{Cooling proportional band coefficient}$$

Therefore,

$$\text{Cooling proportional band coefficient} = 10\%FS / (50\% / 2) = 0.4\%FS$$

To use cooling in ON/OFF (2 position) control, set Cooling proportional band coefficient to "0.0". With heating/cooling control is selected [▶▶ 4-42](#), set both Heating proportional band and Cooling proportional band coefficient to "0.0", and both heating and cooling will be set to ON/OFF actions control (3 positions including dead band and hysteresis). In this situation, ON/OFF control hysteresis is set to 0.5% FS (fixed) for heating and cooling outputs.

The point of operation for the heating output can be shifted with

ON/OFF control hysteresis setting. [▶▶ 4-40](#)

The point of operation for the cooling output can be shifted with

Dead band setting. [▶▶ 4-44](#)

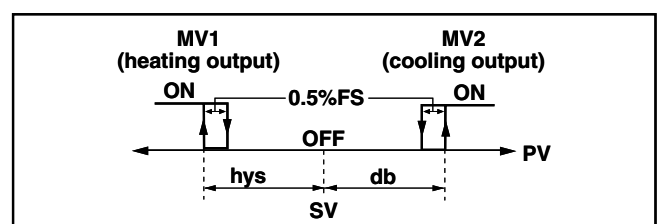

Dead Band Setting

Sets the overlap band or dead band (both outputs OFF) during heating/cooling control.

Each channel (Ch1 to Ch4) has parameters shown below.

Parameter	Range	Unit	Factory default	Attribute	Modbus register number (relative address)
Dead band	-50.0 to 50.0	%	0	R/W	Ch1: 41107 (0452h)
					Ch2: 42107 (083Ah)
					Ch3: 43107 (0C22h)
					Ch4: 44107 (100Ah)

Cooling proportional band shifts with the setting value as shown below.

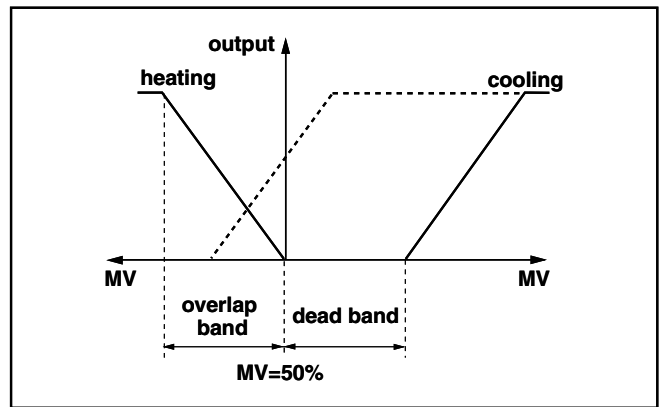

It is called Dead band when the value is positive and Overlap band when the value is negative.

Dead band and Overlap band are measured as a percentage of MV and can be converted to a percentage variation by the following formula.

$$\text{Dead band [\%]} = \text{deviation} \times 100 / \text{Proportional band [\%]}$$

Example: Proportional Band (P) = 5.0%, with a desired dead band of 1.0%FS deviation from SV:

$$\text{Dead band [\%]} = 1.0 \times 100 / 5.0 [\%] = 20 [\%]$$

Output Convergence Value Setting

Sets the amount of offset added to MV value.

Each channel (Ch1 to Ch4) has parameters shown below.

Parameter	Range	Unit	Factory default	Attribute	Modbus register number (relative address)
Output convergence value	-100.0 to 100.0	%	0	R/W	Ch1: 41108 (0453h)
					Ch2: 42108 (083Bh)
					Ch3: 43108 (0C23h)
					Ch4: 44108 (100Bh)

The output convergence value function outputs to PV and SV a calculated result of the PID computed MV plus the offset.

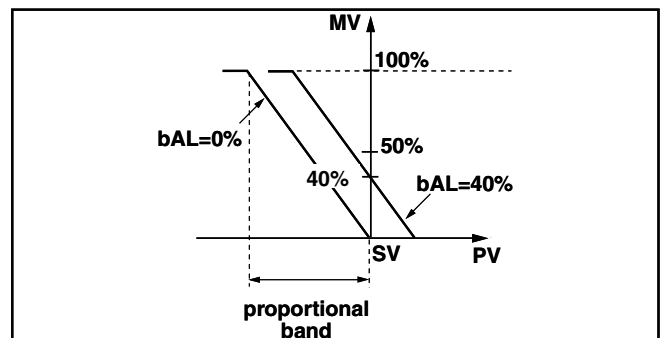

Note

When heating/cooling control is selected, make sure to set the output convergence value to 50%. [▶▶ 4-42](#)

SV Lower and Upper Limits Setting

These settings specify the range to which SV can be set. SV can be set to any value in the measurement range. ▶▶ 4-15

Each channel (Ch1 to Ch4) has parameters shown below.

Parameter	Range	Unit	Factory default	Attribute	Modbus register number (relative address)
SV lower limit	0 to 100	%FS	0	R/W	Ch1: 41218 (04C1h)
					Ch2: 42218 (08A9h)
					Ch3: 43218 (0C91h)
					Ch4: 44218 (1079h)
SV upper limit	0 to 100	%FS	100	R/W	Ch1: 41219 (04C2h)
					Ch2: 42219 (08AAh)
					Ch3: 43219 (0C92h)
					Ch4: 44219 (107Ah)

The relationship between SV limits and the measurement range is as shown below.

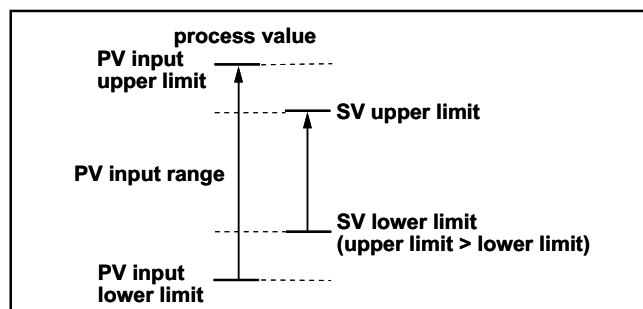

Note

- If SV changed when setting the SV lower/upper limit, the value changed is stored.
- Set the lower and upper SV limits only after completing PV input scale lower and upper settings (See "PV input basic settings" ▶▶ 4-15)
- SV ▶▶ 4-4 which have been set before setting the SV lower and upper limits are affected by new SV limits.
- Make sure to set the value of SV upper limit greater than SV lower limit.

SV Offset

Sets the amount of offset added to SV value.

Each channel (Ch1 to Ch4) has parameters shown below.

Parameter	Range	Unit	Factory default	Attribute	Modbus register number (relative address)
SV value shift	-10 to 10	%FS	0	R/W	Ch1: 41217 (0453h)
					Ch2: 42217 (083Bh)
					Ch3: 43217 (0C23h)
					Ch4: 44217 (100Bh)

This function is used to eliminate remaining offset when using P control. The value set is applied to the SV used for PID calculation.

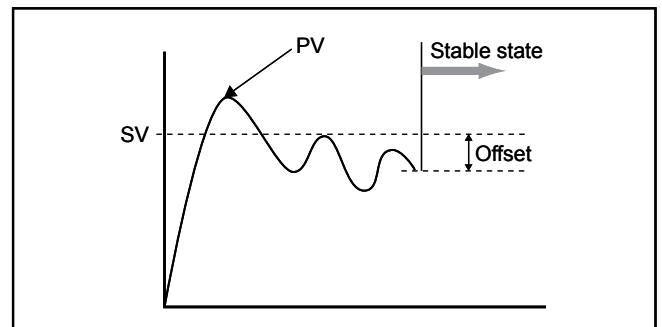

Note

- Controls act on the calculated SV with SV offset added.
- Alarm determination acts on SV without SV offset.
- SV value which are displayed on a monitor are values without SV offset.

▶▶ 4-4

Ramp SV Setting

This function changes a previously set SV to the new value at the ramp rate.

Each channel (Ch1 to Ch4) has parameters shown below.

Parameter	Range	Unit	Factory default	Attribute	Modbus register number (relative address)
Ramp SV ON/OFF	0: OFF 1: ON	None	1	R/W	Ch1: 41299 (0512h)
					Ch2: 42299 (08FAh)
					Ch3: 43299 (0CE2h)
					Ch4: 44299 (10CAh)
Ramp SV decline	0 to 100	%FS	0	R/W	Ch1: 41300 (0513h)
					Ch2: 42300 (08FBh)
					Ch3: 43300 (0CE3h)
					Ch4: 44300 (10CBh)
Ramp SV incline	0 to 100	%FS	0	R/W	Ch1: 41301 (0514h)
					Ch2: 42301 (08FCh)
					Ch3: 43301 (0CE4h)
					Ch4: 44301 (10CCh)
Ramp SV slope time units	0: Slope deg/hr. 1: Slope deg/min.	None	0	R/W	Ch1: 41302 (0515h)
					Ch2: 42302 (08FDh)
					Ch3: 43302 (0CE5h)
					Ch4: 44302 (10CDh)

SV does not change stepwise, but smoothly at the set ramp rate. Incline and decline rates can be set independently.

Operation is as follows for changing SV.

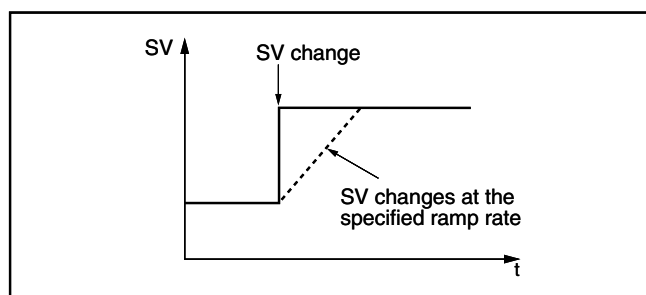

Note

- When Ramp SV decline and incline are set to "0", Ramp SV function will not be performed.
- If set the ramp SV to "valid" in the standby, the SV value comes to be the same as the PV value
- If turning on the power in the state of Ramp SV is "valid", the Ramp SV operation gets start at the PV at the power ON.

Control Output Limiter Type Setting

When limits are specified for the output value, you can choose whether or not to apply the limits.

Each channel (Ch1 to Ch4) has parameters shown below.

Parameter	Range	Unit	Factory default	Attribute	Modbus register number (relative address)
MV1 lower limits	-3.0 to 103.0	%	-3.0	R/W	Ch1: 41255 (04E6h)
					Ch2: 42255 (08CEh)
					Ch3: 43255 (0CB6h)
					Ch4: 44255 (109Eh)
MV1 upper limits	-3.0 to 103.0	%	103.0	R/W	Ch1: 41256 (04E7h)
					Ch2: 42256 (08CFh)
					Ch3: 43256 (0CB7h)
					Ch4: 44256 (109Fh)
MV2 lower limits	-3.0 to 103.0	%	-3.0	R/W	Ch1: 41257 (04E8h)
					Ch2: 42257 (08D0h)
					Ch3: 43257 (0CB8h)
					Ch4: 44257 (10A0h)
MV2 upper limits	-3.0 to 103.0	%	103.0	R/W	Ch1: 41258 (04E9h)
					Ch2: 42258 (08D1h)
					Ch3: 43258 (0CB9h)
					Ch4: 44258 (10A1h)
Output limiter type setting	0 to 15	None	0	R/W	Ch1: 41259 (04EAh)
					Ch2: 42259 (08D2h)
					Ch3: 43259 (0CBAh)
					Ch4: 44259 (10A2h)

Point

When heating/cooling control is selected, MV1 lower and upper limits are applied to heating output, and MV2 lower and upper limits to cooling output.

Output limiter type setting

Refer to the table below and determine the set value.

Set value	MV1		MV2	
	Lower limits	Upper limits	Lower limits	Upper limits
0	-3.0%	103%	-3.0%	103%
1	Lower limits	103%	-3.0%	103%
2	-3.0%	Upper limits	-3.0%	103%
3	Lower limits	Upper limits	-3.0%	103%
4	-3.0%	103%	Lower limits	103%
5	Lower limits	103%	Lower limits	103%
6	-3.0%	Upper limits	Lower limits	103%
7	Lower limits	Upper limits	Lower limits	103%
8	-3.0%	103%	-3.0%	Upper limits
9	Lower limits	103%	-3.0%	Upper limits
10	-3.0%	Upper limits	-3.0%	Upper limits
11	Lower limits	Upper limits	-3.0%	Upper limits
12	-3.0%	103%	Lower limits	Upper limits
13	Lower limits	103%	Lower limits	Upper limits
14	-3.0%	Upper limits	Lower limits	Upper limits
15	Lower limits	Upper limits	Lower limits	Upper limits

The output changes according to the limit, as follows.

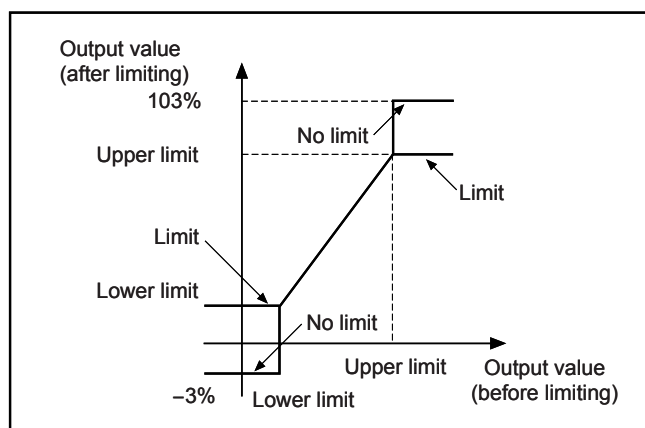

Standby MV Setting

Sets the output value and alarm ON/OFF during standby mode. [▶▶ 4-9](#)

Each channel (Ch1 to Ch4) has parameters shown below.

Parameter	Range	Unit	Factory default	Attribute	Modbus register number (relative address)
Standby MV1 value	-3.0 to 103.0	%	-3.0	R/W	Ch1: 41268 (04F3h)
					Ch2: 42268 (08DBh)
					Ch3: 43268 (0CC3h)
					Ch4: 44268 (10ABh)
Standby MV2 value	-3.0 to 103.0	%	-3.0	R/W	Ch1: 41269 (04F4h)
					Ch2: 42269 (08DCh)
					Ch3: 43269 (0CC4h)
					Ch4: 44269 (10ACh)
Standby mode setting	0 : ALM=OFF 1 : ALM=ON	None	0	R/W	Ch1: 41270 (04F5h)
					Ch2: 42270 (08DDh)
					Ch3: 43270 (0CC5h)
					Ch4: 44270 (10ADh)

Note

The above settings are valid only when the output type is set to MV (set value:3,4, or 7). See "Output source setting"

[▶▶ 4-28](#)

When the output type is other than MV, the value of output source is output.

Soft Start Setting

This function prevents the control output from becoming the maximum output when turning on the module.

Each channel (Ch1 to Ch4) has parameters shown below.

Parameter	Range	Unit	Factory default	Attribute	Modbus register number (relative address)
Soft start MV1 value	-3.0 to 103.0	%	103.0	R/W	Ch1: 41262 (04EDh)
					Ch2: 42262 (08D5h)
					Ch3: 43262 (0CBDh)
					Ch4: 44262 (10A5h)
Soft start MV2 value	-3.0 to 103.0	%	103.0	R/W	Ch1: 41263 (04EEh)
					Ch2: 42263 (08D6h)
					Ch3: 43263 (0CBEh)
					Ch4: 44263 (10A6h)
Soft start time	00:00 to 99:59	hr.:min.	0	R/W	Ch1: 41264 (04EFh)
					Ch2: 42264 (08D7h)
					Ch3: 43264 (0CBFh)
					Ch4: 44264 (10A7h)

Soft start time setting

Soft start time set value is as follows;

Set value for 1 hour and a half : 0130 = 130

Note

Soft star will not be performed if Soft start time is set to 0.

The controls place an upper limit on the output for a set time period after the power is turned on. This function is useful for effects such as suppressing the heater output during equipment startup, or lightening the load. After the specified time has passed after switching on the equipment or if Soft start time is set to 0, the soft start function ends and normal controls begin.

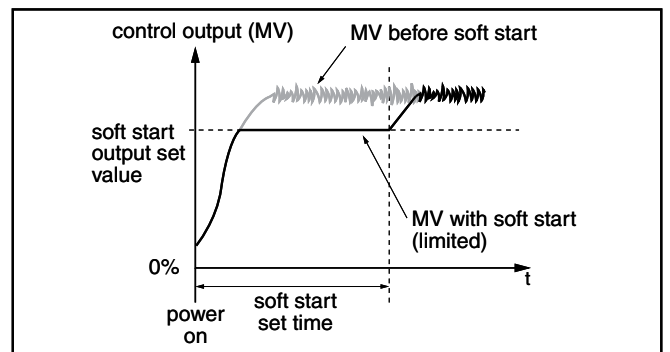

Note

- During manual mode [▶▶ 4-8](#), the manual output value [▶▶ 4-5](#) has priority, but soft start will continue to keep track of the set time period.
- Soft start function cannot be used when dual outputs control is selected. [▶▶ 4-42](#)

Operation Setting when Input Error Occurred

Specifies the output value of MV1/MV2 should this module fall go into the FAULT state (Input Error). Also sets whether to maintain or stop the control when the PV input burnout is detected.

Each channel (Ch1 to Ch4) has parameters shown below.

Parameter	Range	Unit	Factory default	Attribute	Modbus register number (relative address)
FAULT MV1 set value	-3.0 to 103.0	%	-3.0	R/W	Ch1: 41260 (04EBh)
					Ch2: 42260 (08D3h)
					Ch3: 43260 (0CBBh)
					Ch4: 44260 (10A3h)
FAULT MV2 set value	-3.0 to 103.0	%	-3.0	R/W	Ch1: 41261 (04ECh)
					Ch2: 42261 (08D4h)
					Ch3: 43261 (0CBCh)
					Ch4: 44261 (10A4h)
Control when input burnout is detected	0: Stop control 1: Continue control	None	0	R/W	Ch1: 41407 (057Eh)
					Ch2: 42407 (0966h)
					Ch3: 43407 (0D4Eh)
					Ch4: 44407 (1137h)

Note

- If “Control when input burnout is detected” is set to “0:Stop control”, the unit will go into FAULT state and “FAULT MV1/2 set value” will be output when PV input burnout is detected.
- If “Control when input burnout is detected” is set to “1:Continue control”, PID calculation is performed with the burned-out PV value and the preset SV value. Select “0:Stop control” unless otherwise required.
- In manual mode , the manually set value is preferentially output.

Start up Mode Setting

Sets the mode at startup by channel.

Each channel (Ch1 to Ch4) has parameters shown below.

Parameter	Range	Unit	Factory default	Attribute	Modbus register number (relative address)
Mode at startup	0 to 3	None	0	R/W	Ch1: 41304 (0517h)
					Ch2: 42304 (08FFh)
					Ch3: 43304 (0CE7h)
					Ch4: 44304 (10CFh)

Setting the mode at start up

Select the mode from the following options.

Set value	Mode
0	Control output auto mode
1	Control output manual mode
2	Control output auto mode + Remote SV mode
3	Standby mode

When changing a mode from one to another, refer to the instructions of each mode.

4.5 Event Output Setting

Event Output

Followings are types of events this equipment can output.

Event type	Description
Alarm	Control parameters (PV/SV/MV), or the status of loads connected to each channel. Activates alarms when monitored values exceeded the preset values.
Timer code	Switches ON/OFF when it detects the timer which has been set at "ALM delay time" having activated or stopped. ▶▶ 4-64
Status	Indicates the operation status of this equipment in bits.

Each channel of this module has output registers (DO1 to DO5) for 5 event outputs.

Event output setting

To output events, make sure to complete the following settings. Some event types requires DO event type and DO option function settings only.

- DO event type [▶▶ 4-57](#)
- DO option function [▶▶ 4-68](#)
- ALM set value [▶▶ 4-62](#)
- ALM delay time [▶▶ 4-65](#)
- ALM delay time units [▶▶ 4-66](#)
- ALM hysteresis [▶▶ 4-67](#)

Confirming event switching ON/OFF

When this equipment is used stand-alone, or with analog input/output modules only, events assigned to DO1 to DO5 can be confirmed by checking LED lamps on the front face of this equipment.

How to output event signal of control module into event input/output module

In order to output event signal of control module into event input/output module, connect this module to use as event input/output module.

Note

- With digital input (DI), event module used as input source is configured on control module. [▶▶ 4-88](#)
- With digital output (DO), control module used as output source and its output channels are configured on event input/output module.

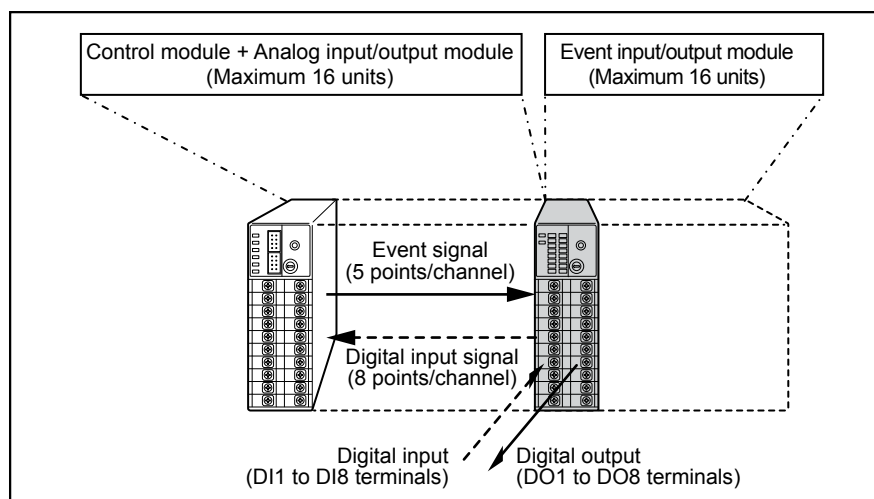

Basic setting items

- Communication settings [▶▶ 4-83](#)
- Output source setting [▶▶ Event input/output module user's manual](#)

DO Event Types

Assign triggers such as alarms, timer, or the status of this equipment to each DO.

Event types assigned to DO1 to DO5 are as shown below.

Parameter	Range	Unit	Factory default	Attribute	Modbus register number (relative address)	
					Ch	Address
DO1 event type	0 to 102	None	0	R/W	Ch1	41032(0407h)
					Ch2	42032(07EFh)
					Ch3	43032(0BD7h)
					Ch4	44032(0FBFh)
DO2 event type	0 to 102	None	0	R/W	Ch1	41040(040Fh)
					Ch2	42040(07F7h)
					Ch3	43040(0BDFh)
					Ch4	44040(0FC7h)
DO3 event type	0 to 102	None	0	R/W	Ch1	41048(0417h)
					Ch2	42048(07FFh)
					Ch3	43048(0BE7h)
					Ch4	44048(0FCFh)
DO4 event type	0 to 102	None	0	R/W	Ch1	41056(041Fh)
					Ch2	42056(0807h)
					Ch3	43056(0BEFh)
					Ch4	44056(0FD7h)
DO5 event type	0 to 102	None	0	R/W	Ch1	41064(0427h)
					Ch2	42064(080Fh)
					Ch3	43064(0BF7h)
					Ch4	44064(0FDFh)

Point

- When an alarm event is assigned, alarm signal is output in the range highlighted in grey of the behavior diagram.
- When alarm hold function is required, select an alarm event with hold function. [▶▶ 4-69](#)

Note

Please do not set values other than event numbers indicated in the table below.





4.5 Event Output Setting

Select event number from the table below.

– No event

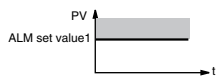
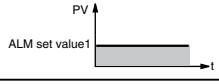
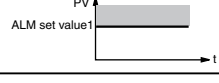
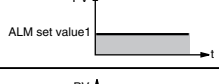
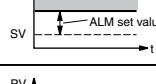

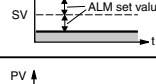
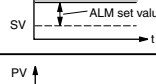
Event category	Event No.	Event type	Behavior diagram	Reference
—	0	None	—	—

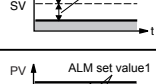
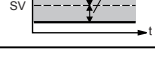
– Alarm event

Event category	Event No.	Event type	Behavior diagram	Reference
PV absolute alarm	1	Upper limit absolute		—
	2	Lower limit absolute		—
	3	Upper limit absolute with hold		—
	4	Lower limit absolute with hold		—
Deviation alarm	5	Upper limit deviation		—
	6	Lower limit deviation		—
	7	Upper/lower limit deviation		—
	8	Upper limit deviation with hold		—
	9	Lower limit deviation with hold		—
	10	Upper/lower limit deviation with hold		—
Range alarm1	11	Range upper/lower limit deviation		—

Event category	Event No.	Event type	Behavior diagram	Reference
Upper / lower limit alarm	16	Upper/lower limit absolute		—
	17	Upper/lower limit deviation		—
	18	Upper limit absolute, lower limit deviation		—
	19	Upper limit deviation, lower limit absolute		—
	20	Upper/lower limit absolute with hold		—
	21	Upper/lower limit deviation with hold		—
	22	Upper limit absolute, lower limit deviation with hold		—
	23	Upper limit deviation, lower limit absolute with hold		—
Range alarm2	24	Range upper/lower limit absolute		—
	25	Range upper/lower limit deviation		—
	26	Range upper limit absolute, lower limit deviation		—
	27	Range upper limit deviation, lower limit absolute		—
	28	Range upper/lower limit absolute with hold		—
	29	Range upper/lower limit deviation with hold		—
	30	Range upper limit absolute, lower limit deviation with hold		—
	31	Range upper limit deviation, lower limit absolute with hold		—
SV alarm	32	SV upper limit		▶▶ 4-71
	33	SV lower limit		
	34	SV upper/lower limit		

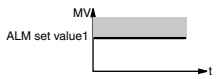
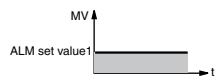
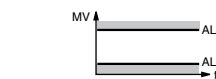
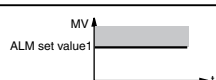
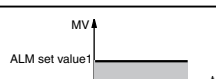
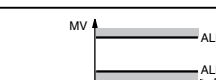
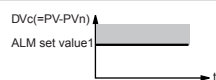
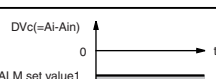
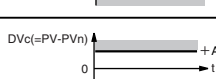
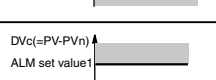
4.5 Event Output Setting

Event category	Event No.	Event type	Behavior diagram	Reference
MV alarm	35	MV upper limit (heat)		▶▶ 4-72
	36	MV lower limit (heat)		
	37	MV upper/lower limit (heat)		
	38	MV upper limit (cool)		
	39	MV lower limit (cool)		
	40	MV upper/lower limit (cool)		
Interchannel PV deviation alarm	41	Interchannel upper limit deviation		▶▶ 4-73
	42	Interchannel lower limit deviation		
	43	Interchannel upper/lower limit deviation		
	44	Interchannel upper limit deviation with hold		
	45	Interchannel lower limit deviation with hold		
	46	Interchannel upper/lower limit deviation with hold		
Break/short-circuit alarm	61	Loop break alarm	—	▶▶ 4-75
	64	CT[A] HB alarm	—	▶▶ 4-77
	65	CT[B] HB alarm		
	66	CT[A] HB alarm or CT[B] HB alarm		
	67	CT[A] load short-circuit alarm	—	▶▶ 4-80
	68	CT[B] load short-circuit alarm		
	69	CT[A] load short-circuit alarm or CT[B] load short-circuit alarm		

Point

- When selecting an event type with either of upper limit or lower limit only, the event always refers to “ALM set value 1”.
- Event No.11 detects whether both negative and positive deviation between PV and SV is within the range of "ALM set value1".

– Events other than alarms

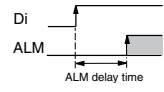
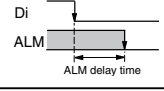
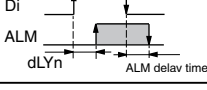
Event category	Event No.	Event type	Behavior diagram	Reference
Timer	52	ON delay timer		
	53	OFF delay timer		▶▶ 4-65 ▶▶ 4-66
	54	ON/OFF delay timer		
Condition output	71	During auto-tuning	—	▶▶ 4-6
	72	Normal Operation	—	
	73	Standby	—	▶▶ 4-9
	74	Manual Mode operating	—	▶▶ 4-8
	75	Remote SV operating	—	▶▶ 4-10
	76	During ramp SV	—	▶▶ 4-48

Relevant parameters

- ALM set value1 / ALM set value2 ▶▶ 4-62
- ALM delay time ▶▶ 4-65
- ALM delay time units ▶▶ 4-66
- ALM hysteresis ▶▶ 4-67
- DO option functions ▶▶ 4-68

ALM Set Value1 / ALM Set Value2

Two different values can be set for alarm event output registers DO1 to DO5. Values set to ALM1 to 5 are applied to DO1 to DO5 respectively.

Parameter	Range	Unit	Factory default	Attribute	Modbus register number (relative address)	
ALM1 set value1	0 to 100%FS (Absolute alarm) -100 to 100%FS (Deviation alarm)	%FS	2.5	R/W	Ch1	41033(0408h)
					Ch2	42033(07F0h)
					Ch3	43033(0BD8h)
					Ch4	44033(0FC0h)
ALM1 set value2	0 to 100%FS (Absolute alarm) -100 to 100%FS (Deviation alarm)	%FS	2.5	R/W	Ch1	41034(0409h)
					Ch2	42034(07F1h)
					Ch3	43034(0BD9h)
					Ch4	44034(0FC1h)
ALM2 set value1	0 to 100%FS (Absolute alarm) -100 to 100%FS (Deviation alarm)	%FS	2.5	R/W	Ch1	41041(0410h)
					Ch2	42041(07F8h)
					Ch3	43041(0BE0h)
					Ch4	44041(0FC8h)
ALM2 set value2	0 to 100%FS (Absolute alarm) -100 to 100%FS (Deviation alarm)	%FS	2.5	R/W	Ch1	41042(0411h)
					Ch2	42042(07F9h)
					Ch3	43042(0BE1h)
					Ch4	44042(0FC9h)
ALM3 set value1	0 to 100%FS (Absolute alarm) -100 to 100%FS (Deviation alarm)	%FS	2.5	R/W	Ch1	41049(0418h)
					Ch2	42049(0800h)
					Ch3	43049(0BE8h)
					Ch4	44049(0FD0h)
ALM3 set value2	0 to 100%FS (Absolute alarm) -100 to 100%FS (Deviation alarm)	%FS	2.5	R/W	Ch1	41050(0419h)
					Ch2	42050(0801h)
					Ch3	43050(0BE9h)
					Ch4	44050(0FD1h)
ALM4 set value1	0 to 100%FS (Absolute alarm) -100 to 100%FS (Deviation alarm)	%FS	2.5	R/W	Ch1	41057(0420h)
					Ch2	42057(0808h)
					Ch3	43057(0BF0h)
					Ch4	44057(0FD8h)
ALM4 set value2	0 to 100%FS (Absolute alarm) -100 to 100%FS (Deviation alarm)	%FS	2.5	R/W	Ch1	41058(0421h)
					Ch2	42058(0809h)
					Ch3	43058(0BF1h)
					Ch4	44058(0FD9h)

Parameter	Range	Unit	Factory default	Attribute	Modbus register number (relative address)	
					Ch	Address
ALM5 set value1	0 to 100%FS (Absolute alarm) –100 to 100%FS (Deviation alarm)	%FS	2.5	R/W	Ch1	41065(0428h)
					Ch2	42065(0810h)
					Ch3	43065(0BF8h)
					Ch4	44065(0FE0h)
ALM5 set value2	0 to 100%FS (Absolute alarm) –100 to 100%FS (Deviation alarm)	%FS	2.5	R/W	Ch1	41066(0429h)
					Ch2	42066(0811h)
					Ch3	43066(0BF9h)
					Ch4	44066(0FE1h)

* FS represents PV input range (full scale).

Point

- When selecting an event type with either of upper limit or lower limit only, the event always refers to "ALM set value 1".
- For an event which has both upper and lower limits such as Range alarm event, both "ALM set value 1" and "ALM set value2" are referred to.

Note

- An event which monitors input from CT terminal refers to values set other than here. [▶▶ 4-77](#)
- To assign loop break detection alarm, also complete parameter settings of "loop break detection time" and "loop break detection band". [▶▶ 4-75](#)

Relative parameters

- DO event types [▶▶ 4-57](#)
- ALM delay time [▶▶ 4-65](#)
- ALM delay time units [▶▶ 4-66](#)
- ALM hysteresis [▶▶ 4-67](#)
- DO option functions [▶▶ 4-68](#)
- Object Channel No. for interchannel ALM [▶▶ 4-73](#)

Operation Before and After Events Output Setting

As an example, the operation of alarm event output is explained.

Following parameters can be set to specify operations before and after alarm events output.

Setting items	Description
ALM delay time / ALM delay time units	Specifies the amount of time from the occurrence of the alarm event to the ON output. Also specifies the unit of time (alarm delay time unit) used to measure the alarm delay.
ALM hysteresis	Specifies alarm detection and recovery width.
DO output latch function	Can be added by DO option functions. Latches (maintains) the state when an event occurs until the latch is released.

The alarm settings, ALM delay time and hysteresis are related as follows.

Example of an Upper Limit Alarm

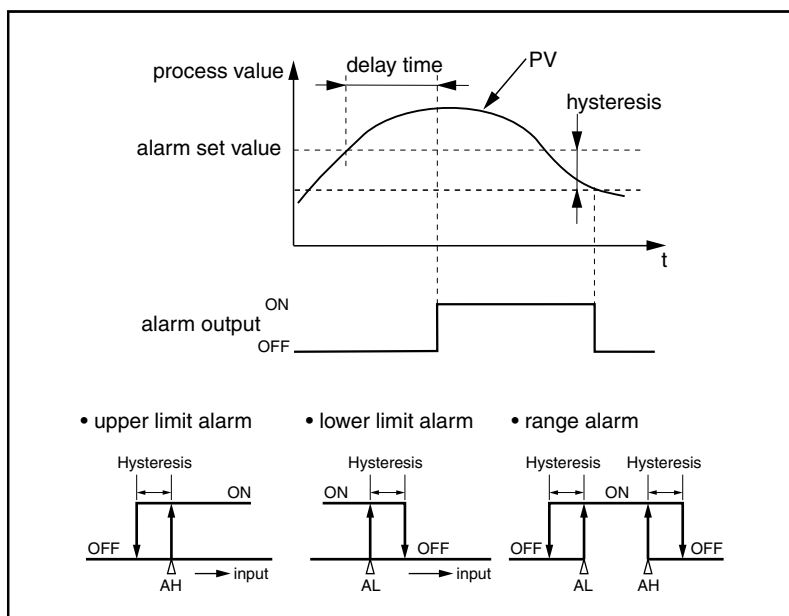

ALM delay time

Is the amount of time from the occurrence of the alarm event to the ON output. The set values are applied to events other than alarm events. Values set to ALM1 to 5 are applied to DO1 to DO5 respectively.

Parameter	Range	Unit	Factory default	Attribute	Modbus register number (relative address)	
					Ch	Address
ALM1 delay time	00:00 to 99.59	Separate setting	00:00	R/W	Ch1	41037 (040Ch)
					Ch2	42037 (07F4h)
					Ch3	43037 (0BDCh)
					Ch4	44037 (0FC4h)
ALM2 delay time	00:00 to 99.59	Separate setting	00:00	R/W	Ch1	41045 (0414h)
					Ch2	42045 (07FCh)
					Ch3	43045 (0BE4h)
					Ch4	44045 (0FCCh)
ALM3 delay time	00:00 to 99.59	Separate setting	00:00	R/W	Ch1	41053 (041Ch)
					Ch2	42053 (0804h)
					Ch3	43053 (0BECh)
					Ch4	44053 (0FD4h)
ALM4 delay time	00:00 to 99.59	Separate setting	00:00	R/W	Ch1	41061 (0424h)
					Ch2	42061 (080Ch)
					Ch3	43061 (0BF4h)
					Ch4	44061 (0FDCh)
ALM5 delay time	00:00 to 99.59	Separate setting	00:00	R/W	Ch1	41069 (042Ch)
					Ch2	42069 (0814h)
					Ch3	43069 (0BFCh)
					Ch4	44069 (0FE4h)

* When the time units is "min./sec.", the maximum time is 99 min.59 sec., and when the time unit is hr./min, the maximum time is 99 hr.59 min.

ALM delay time units

Specifies the unit of time “sec./min.” or “hr./min.” used to measure the alarm delay. Values set to ALM1 to 5 are applied to DO1 to DO5 respectively.

Parameter	Range	Unit	Factory default	Attribute	Modbus register number (relative address)	
ALM1 delay time units	0: sec. 1: min.	—	0	R/W	Ch1	41038 (040Dh)
					Ch2	42038 (07F5h)
					Ch3	43038 (0BDDh)
					Ch4	44038 (0FC5h)
ALM2 delay time units	0: sec. 1: min.	—	0	R/W	Ch1	41046 (0415h)
					Ch2	42046 (07FDh)
					Ch3	43046 (0BE5h)
					Ch4	44046 (0FCDh)
ALM3 delay time units	0: sec. 1: min.	—	0	R/W	Ch1	41054 (041Dh)
					Ch2	42054 (0805h)
					Ch3	43054 (0BEDh)
					Ch4	44054 (0FD5h)
ALM4 delay time units	0: sec. 1: min.	—	0	R/W	Ch1	41062 (0425h)
					Ch2	42062 (080Dh)
					Ch3	43062 (0BF5h)
					Ch4	44062 (0FDDh)
ALM5 delay time units	0: sec. 1: min.	—	0	R/W	Ch1	41070 (042Dh)
					Ch2	42070 (0815h)
					Ch3	43070 (0BFDh)
					Ch4	44070 (0FE5h)

Point

ALM delay ON/OFF can be used as triggers for different kinds of events.  **4-57**

ALM hysteresis

Specifies alarm detection and recovery width.

Values set to ALM1 to 5 are alarm hysteresis which are applied to DO1 to DO5 respectively.

Parameter	Range	Unit	Factory default	Attribute	Modbus register number (relative address)	
					Ch	Address
ALM1 hysteresis	0 to 50%FS	%FS	0.25	R/W	Ch1	41035 (040Ah)
					Ch2	42035 (07F2h)
					Ch3	43035 (0BDAh)
					Ch4	44035 (0FC2h)
ALM2 hysteresis	0 to 50%FS	%FS	0.25	R/W	Ch1	41043 (0412h)
					Ch2	42043 (07FAh)
					Ch3	43043 (0BE2h)
					Ch4	44043 (0FCAh)
ALM3 hysteresis	0 to 50%FS	%FS	0.25	R/W	Ch1	41051 (041Ah)
					Ch2	42051 (0802h)
					Ch3	43051 (0BEAh)
					Ch4	44051 (0FD2h)
ALM4 hysteresis	0 to 50%FS	%FS	0.25	R/W	Ch1	41059 (0422h)
					Ch2	42059 (080Ah)
					Ch3	43059 (0BF2h)
					Ch4	44059 (0FDAh)
ALM5 hysteresis	0 to 50%FS	%FS	0.25	R/W	Ch1	41067 (042Ah)
					Ch2	42067 (0812h)
					Ch3	43067 (0BFAh)
					Ch4	44067 (0FE2h)

* FS represents PV input range (full scale).

Relative parameters

- DO event types [▶▶ 4-57](#)
- ALM set value1 / ALM set value2 [▶▶ 4-62](#)
- DO option functions [▶▶ 4-68](#)

DO Option Function

DO1 to DO5 can each have four types of option functions. The four types of option functions (ON/OFF) are assigned in bit units. Option functions used for DO1 to DO5 are as follows,

Parameter	Range	Unit	Factory default	Attribute	Modbus register number (relative address)	
					Ch	Address
DO1 option function setting	0000 to 1111 bit data (0 to 15)	None	0000 (No setting)	R/W	Ch1	41036(040Bh)
					Ch2	42036 (07F3h)
					Ch3	43036 (0BDBh)
					Ch4	44036 (0FC3h)
DO2 option function setting	0000 to 1111 bit data (0 to 15)	None	0000 (No setting)	R/W	Ch1	41044 (0413h)
					Ch2	42044 (07FBh)
					Ch3	43044 (0BE3h)
					Ch4	44044 (0FCBh)
DO3 option function setting	0000 to 1111 bit data (0 to 15)	None	0000 (No setting)	R/W	Ch1	41052 (041Bh)
					Ch2	42052 (0803h)
					Ch3	43052 (0BEBh)
					Ch4	44052 (0FD3h)
DO4 option function setting	0000 to 1111 bit data (0 to 15)	None	0000 (No setting)	R/W	Ch1	41060 (0423h)
					Ch2	42060 (080Bh)
					Ch3	43060 (0BF3h)
					Ch4	44060 (0FDBh)
DO5 option function setting	0000 to 1111 bit data (0 to 15)	None	0000 (No setting)	R/W	Ch1	41068 (042Bh)
					Ch2	42068 (0813h)
					Ch3	43068 (0BFBh)
					Ch4	44068 (0FE3h)

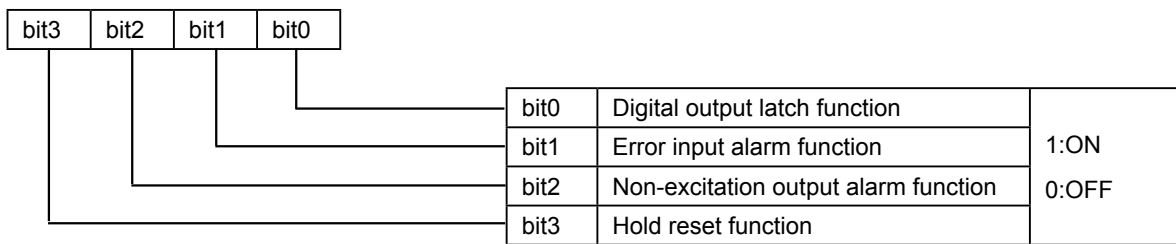

DO output latch function

Latches (maintains) the state when an event occurs. The latch functions will remain ON until the digital output latch release command is set [▶▶ 4-70](#)

Error input alarm function

Outputs an event when an error input enters the unit. Set the DO event type [▶▶ 4-57](#) to "0" to use this function.

Non-excitation output function

Inverts the output and outputs from the DO terminal when an event occurs.

Hold and hold reset function

When alarm events are assigned, sometimes alarms are faultily detected soon after the power was turned ON. When an alarm event with hold function is assigned for a DO event type [▶▶ 4-57](#), the alarm first to occur after the power was turned ON will be ignored to avoid unnecessary alarm outputs.

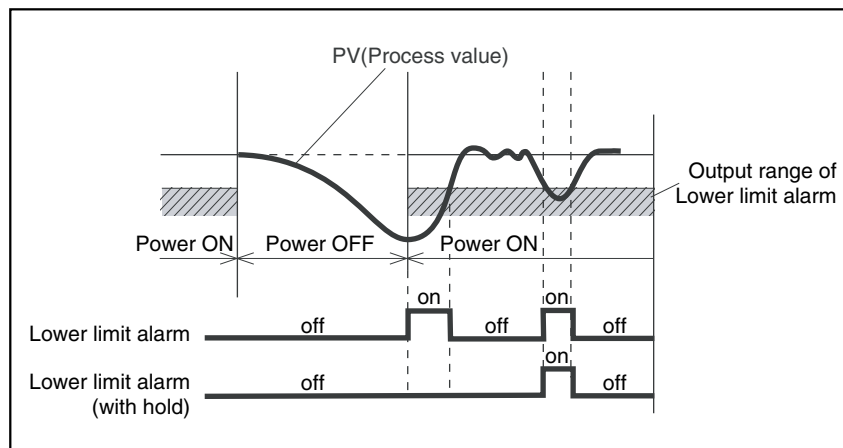

When an alarm with hold is applied, the hold function is reset when any of the following actions occur.

- | | | |
|-------------------|-------------------------|-------------------------|
| - Change SV value | - Change alarm type | - Change alarm settings |
| - Cancel standby | - Turn power OFF and ON | |

When both hold reset and digital output latch functions are set, digital output latch function is applied prior to hold reset.

Relative parameters

- ALM set value1 / ALM set value2 [▶▶ 4-62](#)
- ALM delay time [▶▶ 4-65](#)
- ALM delay time units [▶▶ 4-66](#)
- ALM hysteresis [▶▶ 4-67](#)

Digital Output Latch Release

There are two ways of releasing event latch as shown below.

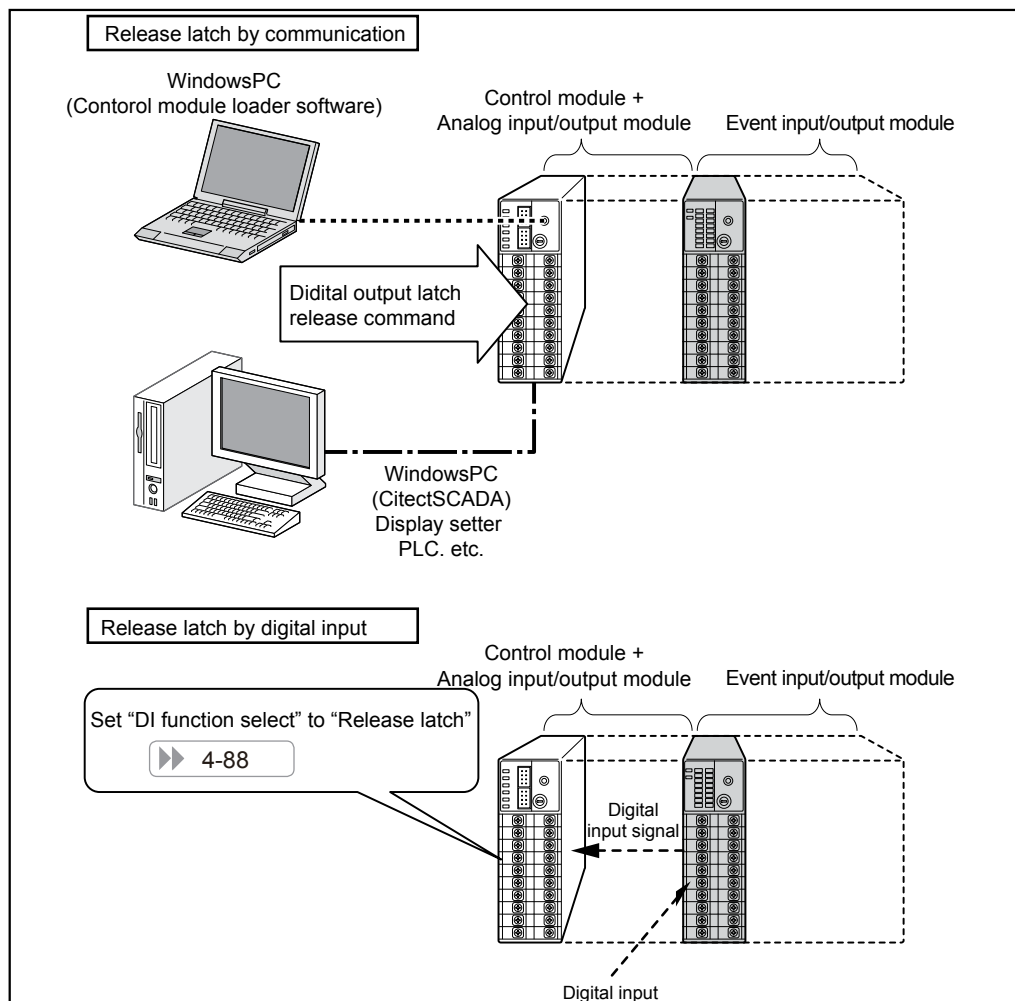

Point

- To enable digital output latch function, set "DO option functions". ▶▶ 4-68
- When "DI function select" is set to "Release latch", digital output latch can be released by digital input from an event input/output module. ▶▶ 4-88

To release latch by communication, set the parameter below to "1: Release latch".

Parameter	Range	Unit	Factory default	Attribute	Modbus register number (relative address)	
Digital output latch release command	0: OFF 1: Release latch	None	0	R/W	Ch1	41031 (0406h)
					Ch2	42031 (07EEh)
					Ch3	43031 (0BD6h)
					Ch4	44031 (0FBEh)

SV Alarm

Sets an alarm for inappropriate SV values. This function gives an alarm for setting mistakes of SV or Remote SV values.

Note

In remote mode, remote SV values are monitored. [▶▶ 4-22](#)

– Event No.

To set SV alarms, assign the following event numbers when configuring “DO event types” setting. [▶▶ 4-57](#)

Event No.	Event type	Behavior diagram
32	SV upper limit	
33	SV lower limit	
34	SV upper/lower limit	

– Other settings

Settings of the relative parameters shown below are the same as other alarm events.

Relative parameters

- ALM set value1 / ALM set value2 [▶▶ 4-62](#)
- ALM delay time [▶▶ 4-65](#)
- ALM delay time units [▶▶ 4-66](#)
- ALM hysteresis [▶▶ 4-67](#)
- DO option functions [▶▶ 4-68](#)

MV Alarm

Sets an alarm for inappropriate MV1 (heating output) and MV2 (cooling output). MV1(heating output) and MV2(cooling output) are set separately.

Point

– In operation modes shown below, MV monitoring and alarm output are performed.

- Manual mode [▶▶ 4-5](#)
- Standby mode [▶▶ 4-51](#)
- Soft start mode [▶▶ 4-52](#)
- Input error status [▶▶ 4-53](#)

– Event No.

To set MV alarms, assign the following event numbers when configuring “DO event types” setting [▶▶ 4-57](#)

Event No.	Event type	Behavior diagram
35	MV upper limit (heating output)	
36	MV lower limit (heating output)	
37	MV upper/lower limit (heating output)	
38	MV upper limit (cooling output)	
39	MV lower limit (cooling output)	
40	MV upper/lower limit (cooling output)	

– Other settings

Settings of the relative parameters shown below are the same as other alarm events.

Relative parameters

- ALM set value1 / ALM set value2 [▶▶ 4-62](#)
- ALM delay time [▶▶ 4-65](#)
- ALM delay time units [▶▶ 4-66](#)
- ALM hysteresis [▶▶ 4-67](#)
- DO option functions [▶▶ 4-68](#)

Interchannel Deviation Alarm

Monitors deviation of PV between channels 1 to 4.

Note

When using interchannel deviation ALM, PV input range setting should be the same on the object two channels of which PV values are to be compared. [▶▶ 4-15](#)

– Event No.

To set interchannel deviation ALM functions, assign the following event numbers when configuring “DO event types” setting

[▶▶ 4-57](#)

Event No.	Event type	Behavior diagram
41	Interchannel upper limit deviation	
42	Interchannel lower limit deviation	
43	Interchannel upper/lower limit deviation	
44	Interchannel upper limit deviation with hold	
45	Interchannel lower limit deviation with hold	
46	Interchannel upper/lower limit deviation with hold	

– Object Ch No. for interchannel ALM

Set “Object Ch No. for interchannel ALM1 to 5” to the desired object channel numbers of which PV values are to be compared. Values set to ALM1 to 5 are object Ch No. for interchannel ALM which are applied to DO1 to DO5 respectively.

Parameter	Range	Unit	Factory default	Attribute	Modbus register number (relative address)	
					Ch	Address
Object Ch No. for interchannel ALM1	1 to 4 (Ch No.)	None	1	R/W	Ch1	41039 (040Eh)
					Ch2	42039 (07F6h)
					Ch3	43039 (0BDEh)
					Ch4	44039 (0FC6h)
Object Ch No. for interchannel ALM2	1 to 4 (Ch No.)	None	1	R/W	Ch1	41047 (0416h)
					Ch2	42047 (07FEh)
					Ch3	43047 (0BE6h)
					Ch4	44047 (0FCEh)

4.5 Event Output Setting

Parameter	Range	Unit	Factory default	Attribute	Modbus register number (relative address)	
					Ch	Address
Object Ch No. for interchannel ALM3	1 to 4 (Ch No.)	None	1	R/W	Ch1	41055 (041Eh)
					Ch2	42055 (0806h)
					Ch3	43055 (0BEEh)
					Ch4	44055 (0FD6h)
Object Ch No. for interchannel ALM4	1 to 4 (Ch No.)	None	1	R/W	Ch1	41063 (0426h)
					Ch2	42063 (080Eh)
					Ch3	43063 (0BF6h)
					Ch4	44063 (0FDEh)
Object Ch No. for interchannel ALM5	1 to 4 (Ch No.)	None	1	R/W	Ch1	41071 (042Eh)
					Ch2	42071 (0816h)
					Ch3	43071 (0BFEh)
					Ch4	44071 (0FE6h)

– Other settings

Settings of the relative parameters shown below are the same as other alarm events.

Relative parameters

- ALM set value1 / ALM set value2 [▶▶ 4-62](#)
- ALM delay time [▶▶ 4-65](#)
- ALM delay time units [▶▶ 4-66](#)
- ALM hysteresis [▶▶ 4-67](#)
- DO option functions [▶▶ 4-68](#)

Loop Break Alarm

Detects loop break by monitoring process value (PV) change according to control output (MV). Starts to monitor when MV is 0 or 100% and checks PV change in regular intervals (“Loop break detection time”). If PV does not change beyond the range of specified band (“Loop break detection band”), loop break alarm will occur.

Loop break detection time and width are related as follows.

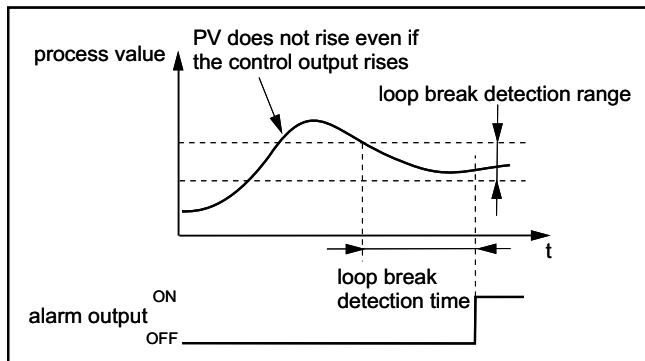

Note

- Please do not use this function when “Direct/Reverse setting” is set to dual control mode. [▶▶ 4-42](#)
- When there is an input error or setting error, a loop break alarm event will be output even before the loop break detection time passes.

– Event No.

To set loop break alarm function, assign the following event number when configuring “DO event types” setting [▶▶ 4-57](#)

Event No.	Event type	Behavior diagram
61	Loop break alarm	—

– Loop break detection time

Specifies how much time must pass before the loop is determined to be broken.

Parameter	Range	Unit	Factory default	Attribute	Modbus register number (relative address)	
					Ch1	Ch2
Loop break detection time	0 to 9999	sec.	0	R/W	Ch1	41080 (0437h)
					Ch2	42080 (081Fh)
					Ch3	43080 (0C07h)
					Ch4	44080 (0FEFh)

4.5 Event Output Setting

– Loop break detection band

Sets the temperature range of PV which must be achieved within a specified detection time.

Parameter	Range	Unit	Factory default	Attribute	Modbus register number (relative address)	
Loop break detection band	0 to 100%FS	%FS	2.5	R/W	Ch1	41081 (0438h)
					Ch2	42081 (0820h)
					Ch3	43081 (0C08h)
					Ch4	44081 (0FF0h)

* FS represents PV input range (full scale).

– Other settings

Settings of the relative parameters shown below are the same as other alarm events.

Relative parameters

- ALM set value1 / ALM set value2 ▶▶ 4-62
- ALM delay time ▶▶ 4-65
- ALM delay time units ▶▶ 4-66
- ALM hysteresis ▶▶ 4-67
- DO option functions ▶▶ 4-68

HB (Heater Break) Alarm

Detects heater break when the value of current through CT is below the specified value (HB alarm set value) during control output is ON.

Note

- This function is used only for relay output and SSR output types. This function cannot be used when the heater is controlled by thyristor phase angle control.
- It requires 400ms (0.4 sec) or more until control output is switched ON.

– Event No.

To set heater break alarm function, assign the following event number when configuring “DO event types” setting **▶▶ 4-57**

Event No.	Event type
64	CT[A] HB alarm
65	CT[B] HB alarm
66	CT[A] HB alarm OR CT[B] HB alarm

Point

Select “CT[A] HB alarm” or “CT[B] HB alarm” for single phase power supply. In case of three phase power supply, select “CT[A] HB alarm OR CT[B] HB alarm”.

– HB alarm set value

The electric current set value at which an alarm occurs.

Parameter	Range	Unit	Factory default	Attribute	Modbus register number (relative address)	
					Ch	Address
CT[A] HB alarm set value	0.0 to 50.0	A (digit)	0	R/W	Ch1	41072 (042Fh)
					Ch2	42072 (0817h)
					Ch3	43072 (0BFFh)
					Ch4	44072 (0FE7h)
CT[B] HB alarm set value	0.0 to 50.0	A (digit)	0	R/W	Ch1	41076 (0433h)
					Ch2	42076 (081Bh)
					Ch3	43076 (0C03h)
					Ch4	44076 (0FEBh)

Point

In case of three phase power supply, determine the HB alarm set value considering voltage fluctuations of the heater.

4.5 Event Output Setting

– HB alarm hysteresis

Specifies the value which the input current value through CT terminal should recover from the HB alarm set value and to be judged normal.

Parameter	Range	Unit	Factory default	Attribute	Modbus register number (relative address)	
					Ch	Address
CT[A] HB alarm hysteresis	0.0 to 50.0	A (digit)	0.5	R/W	Ch1	41073 (0430h)
					Ch2	42073 (0818h)
					Ch3	43073 (0200h)
					Ch4	44073 (0FE8h)
CT[B] HB alarm hysteresis	0.0 to 50.0	A (digit)	0.5	R/W	Ch1	41077 (0434h)
					Ch2	42077 (0812h)
					Ch3	43077 (0C04h)
					Ch4	44077 (0FE2h)

The relationship between the heater break alarm set value and hysteresis is as shown below.

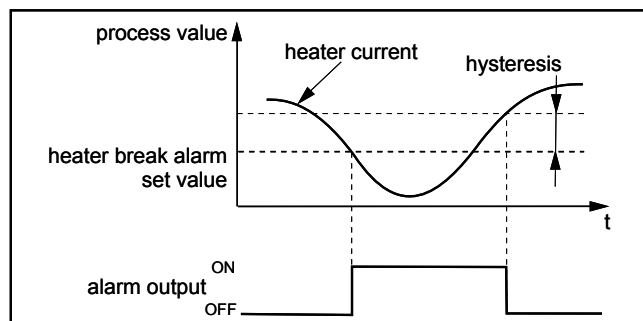

– Other settings

Settings of the relative parameters shown below are the same as other alarm events.

Relative parameters

- ALM delay time [▶▶ 4-65](#)
- ALM delay time units [▶▶ 4-66](#)
- DO option functions [▶▶ 4-68](#)

CT terminal connection method

Before setting HB break alarm, complete wiring between the CT and CT (current transformer) terminals of this equipment. Examples are shown below.

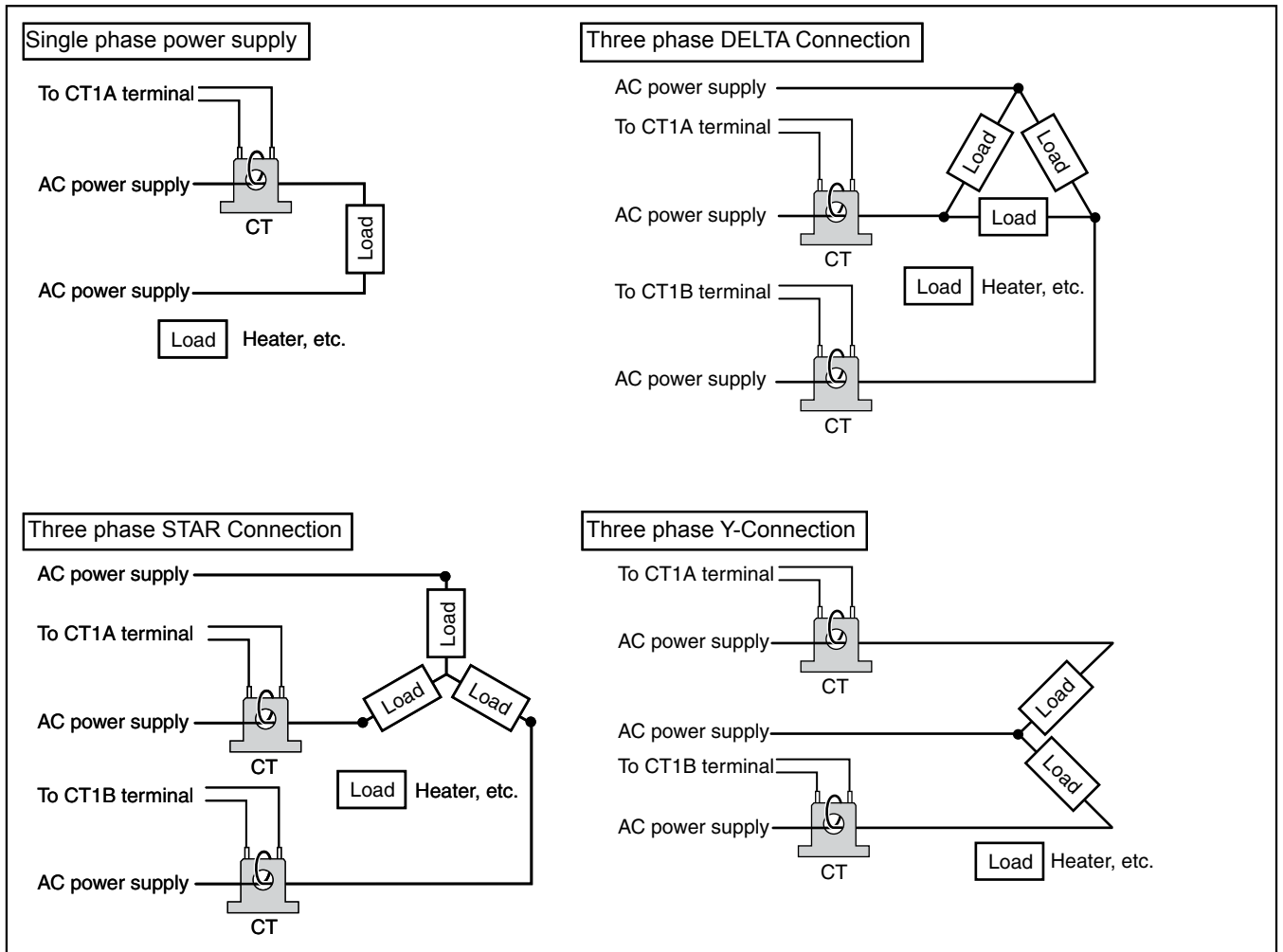

Point

- When the margin of detection error is large due to low heater capacity, thread the cable into the hole of CT twice to double the current so that the sensitivity increases. Be sure to double the HB alarm set value in such cases.
- When threading the cable into the hole of CT, be sure to do so from the same direction.
- CT is connected as shown below.

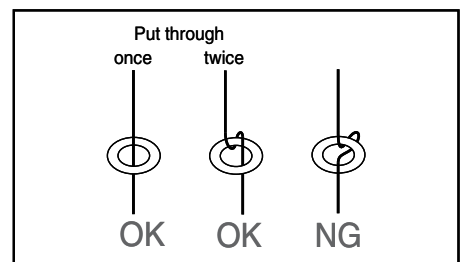
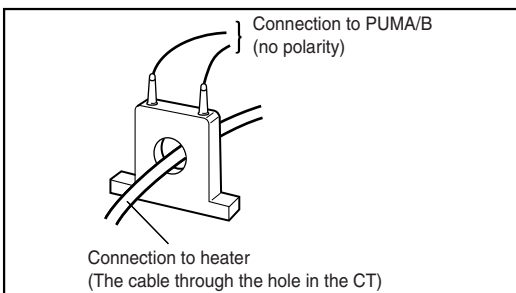

Load Short-circuit Alarm

Detects short-circuiting of the SSR or magnet conductor when the value of current through CT is above the specified value (Load short-circuit alarm set value) during control output is OFF.

Before setting Load short-circuit alarm, complete wiring between CT and CT terminals of this equipment in the same manner as HB alarm. ▶▶ 4-79

Note

- This function is used only for relay or SSR output types. This is not used when the heater is controlled by thyristor phase angle control.
- It requires 2 or more seconds until output is switched OFF.

– Event number

To set load short-circuit alarm function, assign the following event number when configuring “DO event types” setting ▶▶ 4-57

Event No.	Event type
67	CT[A] load short-circuit alarm
68	CT[B] load short-circuit alarm
69	CT[A] load short-circuit alarm OR CT[B] load short-circuit alarm

Point

Select “CT[A] load short-circuit alarm” or “CT[B] load short-circuit alarm” for single phase power supply. In case of three phase power supply, select “CT[A] load short-circuit alarm OR CT[B] load short-circuit alarm”

– Load short-circuit alarm set value

Sets the electric current set value at which an alarm occurs. Decide the value depending on the size of CT.

Parameter	Range	Unit	Factory default	Attribute	Modbus register number (relative address)	
					Ch	Address
CT[A] load short-circuit alarm set value	0.0 to 50.0	A (digit)	0	R/W	Ch1	41074 (0431h)
					Ch2	42074 (0819h)
					Ch3	43074 (0C01h)
					Ch4	44074 (0FE9h)
CT[B] load short-circuit alarm set value	0.0 to 50.0	A (digit)	0	R/W	Ch1	41078 (0435h)
					Ch2	42078 (081Dh)
					Ch3	43078 (0C05h)
					Ch4	44078 (0FEDh)

– Load short-circuit alarm hysteresis

Specifies the value which the input current value through CT terminal should decrease from the load short-circuit alarm set value and to be judged normal.

Parameter	Range	Unit	Factory default	Attribute	Modbus register number (relative address)	
					Ch	Address
CT[A] load short-circuit alarm hysteresis	0.0 to 50.0	A (digit)	0.5	R/W	Ch1	41075 (0432h)
					Ch2	42075 (081Ah)
					Ch3	43075 (0C02h)
					Ch4	44075 (0FEAh)
CT[B] load short-circuit alarm hysteresis	0.0 to 50.0	A (digit)	0.5	R/W	Ch1	41079 (0436h)
					Ch2	42079 (081Eh)
					Ch3	43079 (0C06h)
					Ch4	44079 (0FEEh)

The relationship between the load short-circuit alarm set value and hysteresis is as shown below.

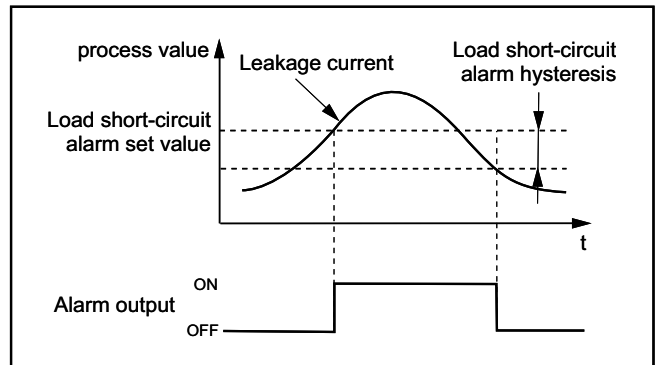

– Other settings

Settings of the relative parameters shown below are the same as other alarm events.

Relative parameters

- ALM delay time ▶▶ 4-65
- ALM delay time units ▶▶ 4-66
- DO option functions ▶▶ 4-68

4.6 Communication Setting

Communication Setting

The following communication settings can be performed on this module.

- RS-485 Communication speed setting and RS-485 parity setting **▶▶ 4-83**
- RS-485 Communication permission setting **▶▶ 4-84**
- Enhanced Communication module (PUMC) connection permission **▶▶ 4-84**
- Master/slave setting in connected modules **▶▶ 4-85**
- RS-485 Response interval time setting **▶▶ 4-86**

The parameters reset the main unit is necessary when change the setting are marked **(RST)** in each setting explanation or parameter.

RS-485 Communication Speed Setting and RS-485 Parity Setting **(RST)**

It is for setting transmission speeds and parity checks of external communication using RS-485.

Each module has the parameters shown below.

Parameter	Range	Unit	Factory default	Attribute	Modbus register number (relative address)
RS-485 Communication speed	0: 9.6kbps 1: 19.2kbps 2: 38.4kbps 3: No Setting 4: 115.2kbps	None	1	R/W	40115(0072h)
RS-485 Parity setting	0: None 1: Odd 2: Even	None	0	R/W	40111(006Eh)

Note

The communication speed and parity settings of the master and all slaves on the same communication system should be the same. If these settings are not the same, communication can not be performed.

RS-485 Communication Permission Setting

It is for setting Read/Write permission of external communication using RS-485/loader communication.

Each module has the parameter shown below.

Parameter	Range	Unit	Factory default	Attribute	Modbus register number (relative address)
RS-485 Communication permission	0: Read only 1: Read/Write	None	1	R/W	40114(0071h)

Note

- When connecting an enhanced communication module (CC-Link, etc.), “RS-485 Communication permission” is set to “1: Read/Write” on all module.
- Once “0: Read only” is set, parameters except for “RS-485 Communication permission” can not be changed (to Write). A response will be returned to Write, however, actual Write will not be performed.

Enhanced Communication Module (PUMC) Connection Permission RST

It is for setting permission of inter-module communication when the enhanced communication module (PUMC) is connected.

Each module has the parameter shown below.

Parameter	Range	Unit	Factory default	Attribute	Modbus register number (relative address)
Enhanced communication module (PUMC) connection	0: PUMC not connected (RS-485 Enable) 1: PUMC connected (RS-485 Disable)	None	0	R/W	40116(0073h)

Note

Even if “0: PUMC not connected (RS-485 Enable)” is set to one of the multiple modules, this communication setting does not influence the settings of the modules after this module. The permission setting is valid only for the module to which the permission setting is given.

Master/Slave Setting in Connected Modules



Specifies whether each of connected modules is master or slave.

Each module has the parameter shown below.

Parameter	Range	Unit	Factory default	Attribute	Modbus register number (relative address)
Master/slave setting in connected modules	0: Master 1: Slave	None	1	R/W	40117(0074h)

By setting one of connected control module controllers (4Ch type PUMA / 2Ch type PUMB) as the master ("0: Master"), intermodule communication between all connected module.

Example of system configuration

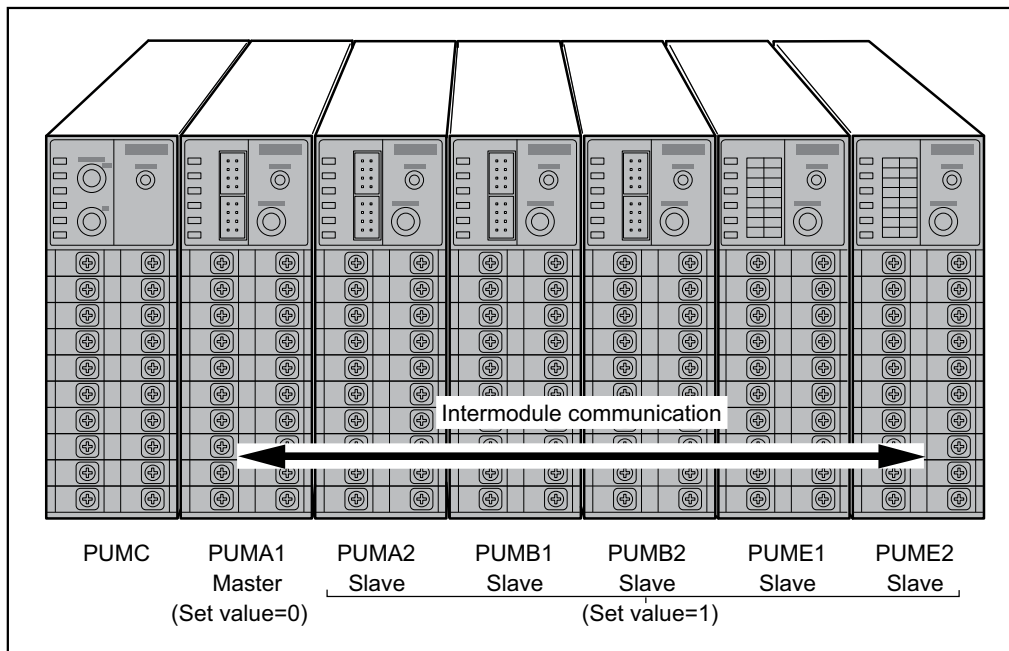

Note

- Only 1 unit can be set as the maser ("0: Master").
- Setting change is valid only after resetting the main unit.

RS-485 Response Interval Time Setting

It is for setting response interval time of RS-485 communication.

Point

In RS-485 communication, transmitting and receiving are performed only on a single transmission line, therefore, switching between transmitting and receiving must be performed with precise timing. For this reason, response interval time must be set to secure the time after transmission of a host, that is a communication partner, is completed until the transmission line is switched to receiving.

The length of interval time should be set to suit a host that is a communication partner.

Each module has the parameter shown below.

Parameter	Range	Unit	Factory default	Attribute	Modbus register number (relative address)
RS-485 Response interval time	0 to 25	20ms/1digit	1	R/W	40113(0070h)

Note

- Note that the response interval time is 20ms for every set value 1. The response interval time up to 500 ms can be set.
 - The response interval time setting for the master and all slaves on the same communication system must be the same.
-

4.7 Optional Functions Setting

Optional Functions Setting

The following functions can be added to this module.

The parameters reset the main unit is necessary when change the setting are marked **(RST)** in each setting explanation or parameter.

DI function

- Digital input function setting ▶▶ 4-88
- Linkage operation setting ▶▶ 4-92

Monitoring function for this module

- Input/output monitor setting ▶▶ 4-96
- LED display setting ▶▶ 4-103

Other functions

- User address specification communication ▶▶ 4-106
- Reset main unit ▶▶ 4-107

Digital Input Function Setting

Assigns the function which activates when a digital signal is input from DI1 to DI 8 in cases event input/output module are connected.

Note

Each channel can use only one unit of event input/output module.

Each channel (Ch1 to Ch4) has parameters shown below.

Parameter	Range	Unit	Factory default	Attribute	Modbus register number (relative address)
DI master Station No. setting 	0 to 255	None	0	R/W	Ch1: 41011 (03F2h)
					Ch2: 42011 (07DAh)
					Ch3: 43011 (0BC2h)
					Ch4: 44011 (0FAAh)
DI-1 function select	0 to 52	None	0	R/W	Ch1: 41013 (03F4h)
					Ch2: 42013 (07DCh)
					Ch3: 43013 (0BC4h)
					Ch4: 44013 (0FAC h)
DI-2 function select	0 to 52	None	0	R/W	Ch1: 41014 (03F5h)
					Ch2: 42014 (07DDh)
					Ch3: 43014 (0BC5h)
					Ch4: 44014 (0FADh)
DI-3 function select	0 to 52	None	0	R/W	Ch1: 41015 (03F6h)
					Ch2: 42015 (07DEh)
					Ch3: 43015 (0BC6h)
					Ch4: 44015 (0FAEh)
DI-4 function select	0 to 52	None	0	R/W	Ch1: 41016 (03F7h)
					Ch2: 42016 (07DFh)
					Ch3: 43016 (0BC7h)
					Ch4: 44016 (0FAFh)
DI-5 function select	0 to 52	None	0	R/W	Ch1: 41017 (03F8h)
					Ch2: 42017 (07E0h)
					Ch3: 43017 (0BC8h)
					Ch4: 44017 (0FB0h)

Parameter	Range	Unit	Factory default	Attribute	Modbus register number (relative address)
DI-6 function select	0 to 52	None	0	R/W	Ch1: 41018 (03F9h)
					Ch2: 42018 (07E1h)
					Ch3: 43018 (0BC9h)
					Ch4: 44018 (0FB1h)
DI-7 function select	0 to 52	None	0	R/W	Ch1: 41019 (03FAh)
					Ch2: 42019 (07E2h)
					Ch3: 43019 (0BCAh)
					Ch4: 44019 (0FB2h)
DI-8 function select	0 to 52	None	0	R/W	Ch1: 41020 (03FBh)
					Ch2: 42020 (07E3h)
					Ch3: 43020 (0BCBh)
					Ch4: 44020 (0FB3h)

DI master Station No. Setting

The set value of “DI master Station No. setting” is the number of station number configuration switch of the object event input/output module plus “17”.

For example, when the station number configuration switch is set to “1”;

The set value of “DI master Station No. setting” should be “18”.

4.7 Optional Functions Setting

The set value for “DI function select”

See the table below to decide which function to assign DI 1 to DI 5.

Set value	Function name	Description	ON	OFF	Judgment condition
0	No function	No function	-	-	-
1	RUN/Standby switch	Switches between Standby ON and OFF(RUN)	Standby	RUN (Standby OFF)	Edge
2	Auto/Manual switch	Switches between auto and manual control output	Manual	Auto	Edge
3	Local/Remote switch	Switches between local and remote SV	Remote	Local	Edge
4-5	No function	Do not set	-	-	-
6	Start AT (Normal type)	Run standard auto-tuning	Run	Stop	Edge
7	Start AT (Low PV type)	Run low PV type auto-tuning	Run	Stop	Edge
8-9	No function	Do not set	-	-	-
10	Ramp SV ON/OFF	Enables or disables Ramp SV	OFF	ON	Edge
11	Ramp SV HOLD	Switches between Ramp SV HOLD and HOLD cancel	Hold	Hold cancel	Edge
12-16	No function	Do not set	-	-	-
17	Latch release (all)	Cancels all of the sources currently acting as latches	Release	-	Edge
18	Latch release (DO1)	Cancels the source currently acting as a latch on DO1	Release	-	Edge
19	Latch release (DO2)	Cancels the source currently acting as a latch on DO2	Release	-	Edge
20	Latch release (DO3)	Cancels the source currently acting as a latch on DO3	Release	-	Edge
21	Latch release (DO4)	Cancels the source currently acting as a latch on DO4	Release	-	Edge
22	Latch release (DO5)	Cancels the source currently acting as a latch on DO5	Release	-	Edge
23-25	No function	Do not set	-	-	-
26	Start timer (DO1)	Starts the specified timer for DO1	Timer ON	Timer OFF	Level
27	Start timer (DO2)	Starts the specified timer for DO2	Timer ON	Timer OFF	Level
28	Start timer (DO3)	Starts the specified timer for DO3	Timer ON	Timer OFF	Level
29	Start timer (DO4)	Starts the specified timer for DO4	Timer ON	Timer OFF	Level
30	Start timer (DO5)	Starts the specified timer for DO5	Timer ON	Timer OFF	Level
31-48	No function	Do not set	-	-	-
49	Output 1 shutdown	Output 1 is set to 0%	Output 0%	-	Level
50	Output 2 shutdown	Output 2 is set to 0%	Output 0%	-	Level
51	Output 3 shutdown	Output 3 is set to 0%	Output 0%	-	Level
52	Output 4 shutdown	Output 4 is set to 0%	Output 0%	-	Level

Note

When the DI function for edge operations is selected, please note the followings.

- The power to the unit is turned on with DI turned on, the ON edge is accepted and the selected function is performed.
 - The power to the unit is turned ON with DI turned OFF, the OFF edge is rejected and the selected function is not performed. To perform the selected function, switch DI OFF, ON, and OFF again to put DI into the OFF edge.
 - In case Remote input master station No. , output master station No. and linkage operation master station No. have been also set as well as DI master station No., the red lamp of PWR LED will be illuminated (system FAULT) if none of the station numbers exist. PWR LED lamp will not be illuminated if any of the station numbers exists.
-

Linkage Operation Setting

Switches the operation mode of multiple channels in response to that of the master channel.

Each channel (Ch1 to Ch4) has parameters below.

Parameter	Range	Unit	Factory default	Attribute	Modbus register number (relative address)
Linkage operation master Station No.	0 to 255	None	0 (own station No.)	R/W	Ch1: 41536 (05FFh)
					Ch2: 42536 (09E7h)
					Ch3: 43536 (0DCFh)
					Ch4: 44536 (11B7h)
Linkage operation master Ch No.	1 to 4	None	own Ch No.	R/W	Ch1: 41537 (0600h)
					Ch2: 42537 (09E8h)
					Ch3: 43537 (0DD0h)
					Ch4: 44537 (11B8h)
DI-9 function select	0 to 52	None	0	R/W	Ch1: 41021 (03FCh)
					Ch2: 42021 (07E4h)
					Ch3: 43021 (0BCCh)
					Ch4: 44021 (0FB4h)
DI-10 function select	0 to 52	None	0	R/W	Ch1: 41022 (03FDh)
					Ch2: 42022 (07E5h)
					Ch3: 43022 (0BCDh)
					Ch4: 44022 (0FB5h)
DI-11 function select	0 to 52	None	0	R/W	Ch1: 41023 (03FEh)
					Ch2: 42023 (07E6h)
					Ch3: 43023 (0BCEh)
					Ch4: 44023 (0FB6h)
DI-12 function select	0 to 52	None	0	R/W	Ch1: 41024 (03FFh)
					Ch2: 42024 (07E7h)
					Ch3: 43024 (0BCFh)
					Ch4: 44024 (0FB7h)
DI-13 function select	0 to 52	None	0	R/W	Ch1: 41025 (0400h)
					Ch2: 42025 (07E8h)
					Ch3: 43025 (0BD0h)
					Ch4: 44025 (0FB8h)

Parameter	Range	Unit	Factory default	Attribute	Modbus register number (relative address)
DI-14 function select	0 to 52	None	0	R/W	Ch1: 41026 (0401h)
					Ch2: 42026 (07E9h)
					Ch3: 43026 (0BD1h)
					Ch4: 44026 (0FB9h)
DI-15 function select	0 to 52	None	0	R/W	Ch1: 41027 (0402h)
					Ch2: 42027 (07EAh)
					Ch3: 43027 (0BD2h)
					Ch4: 44027 (0FBAh)
DI-16 function select	0 to 52	None	0	R/W	Ch1: 41028 (0403h)
					Ch2: 42028 (07EBh)
					Ch3: 43028 (0BD3h)
					Ch4: 44028 (0FBBh)

Master Ch No. setting

Set "Linkage operation master station No." to the No. of module (station number configuration switch) which acts as a trigger of linkage operation plus 1 and set "Linkage operation Ch No." to its Ch No.

To perform linkage operation intramodule, set "Linkage operation master station No." to "0" or to own No. (station number configuration switch plus 1). Please note that if "Linkage operation master Ch No." is set to own No., linkage operation is not operated.

How Linkage operation works

Switching the operation mode of the master channel of the master station turns ON the corresponding DI function No. of own channel, which activates the designated DI function.

Operation mode of master Ch and corresponding DI No.

Operation mode of master channel of master station	Corresponding DI function No. of others
Remote	DI-11
Standby	DI-13
Manual	DI-14
Local	DI-15
Error input	DI-16

Refer to "The set value for "DI function select"" for types of DI functions to be designated.  4-90

Note

- DI-9, 10, and 12 cannot be used for linkage operation.
- In case Remote input master station No. , DI master station No., and output master station No. have been also set as well as linkage operation master station No., the red lamp of PWR LED will be illuminated (system FAULT) if none of the station numbers exist. PWR LED lamp will not be illuminated if any of the station numbers exists.

Example of setting

Ex.1 Switching the all channels of 1 unit control module to Remote SV operation when the master Ch switched to Remote operation.

- Set own Ch 1 as “Linkage operation master Ch No.” (No need to designate DI function when own Ch is the master Ch.)
- Set “Linkage operation master Ch No.” of Ch 2, 3 and 4 to own Ch 1. Assign the DI function, “3: Local/Remote switch” , to the corresponding DI function No. 11.

The setting details are as follows.

Ch	Parameter name	Set value
Ch1	Linkage operation master Station No.	0
	Linkage operation master Ch No.	1
Ch2	Linkage operation master Station No.	0
	Linkage operation master Ch No.	1
	DI function No.11 designation	3
Ch3	Linkage operation master Station No.	0
	Linkage operation master Ch No.	1
	DI function No.11 designation	3
Ch4	Linkage operation master Station No.	0
	Linkage operation master Ch No.	1
	DI function No.11 designation	3

By this setting, switching Ch1 to Remote mode automatically switches all channels to Remote mode operation.

Ex.2 Switching all Ch of 2 units control module to Standby mode when the master Ch switched to Standby mode.

- The station numbers are “1” and “3”.
- Set Ch1 of the station No.1 as the master. (No need to designate DI function when own Ch is the master Ch.)
- Set Ch1 of own station as the master for Ch 2, 3 and 4 of the station No.1. Assign the DI function, “1: RUN/Standby switch” , to the corresponding DI function No. 13.
- As for station No.3, set Ch1 of the station No.1 as the master. Assign the DI function, “1: RUN/Standby switch” , to the corresponding DI function No. 13.

The setting details are as follows.

Ch	Parameter name	Set value
Station No.1		
Ch1	Linkage operation master Station No.	0
	Linkage operation master Ch No.	1
Ch2	Linkage operation master Station No.	0
	Linkage operation master Ch No.	1
	DI function No.13 designation	1
Ch3	Linkage operation master Station No.	0
	Linkage operation master Ch No.	1
	DI function No.13 designation	1
Ch4	Linkage operation master Station No.	0
	Linkage operation master Ch No.	1
	DI function No.13 designation	1
Station No.3		
Ch1	Linkage operation master Station No.	1
	Linkage operation master Ch No.	1
	DI function No.13 designation	1
Ch2	Linkage operation master Station No.	1
	Linkage operation master Ch No.	1
	DI function No.13 designation	1
Ch3	Linkage operation master Station No.	1
	Linkage operation master Ch No.	1
	DI function No.13 designation	1
Ch4	Linkage operation master Station No.	1
	Linkage operation master Ch No.	1
	DI function No.13 designation	1

By this setting, switching Ch1 of the station No.1 to Standby mode automatically switches all channels of the stations No.1 and 3 to Standby mode operation.

Input/Ouput Monitor Setting

The monitor allows you to verify the current input and output conditions of the module.

The monitor can display the following items.

Each channel (Ch1 to Ch4) has parameters shown below.

Parameter	Unit	Attribute	Modbus register number (relative address)
Measurement value (PV)	%FS	R	Ch1: 30002 (0001h) 31001 (03E8h)
			Ch2: 30003 (0002h) 32001 (07D0h)
			Ch3: 30004 (0003h) 33001 (0BB8h)
			Ch4: 30005 (0004h) 34001 (0FA0h)
Set value (SV)	%FS	R	Ch1: 30006 (0005h) 31002 (03E9h)
			Ch2: 30007 (0006h) 32002 (07D1h)
			Ch3: 30008 (0007h) 33002 (0BB9h)
			Ch4: 30009 (0008h) 34002 (0FA1h)
DV	%FS	R	Ch1: 30010 (0009h) 31003 (03EAh)
			Ch2: 30011 (000Ah) 32003 (07D2h)
			Ch3: 30012 (000Bh) 33003 (0BBAh)
			Ch4: 30013 (000Ch) 34003 (0FA2h)
Output value (MV1)	%	R	Ch1: 30014 (000Dh) 31004 (03EBh)
			Ch2: 30016 (000Fh) 32004 (07D3h)
			Ch3: 30018 (0011h) 33004 (0BBBh)
			Ch4: 30020 (0013h) 34004 (0FA3h)

Parameter	Unit	Attribute	Modbus register number (relative address)
Output value (MV2)	%	R	Ch1: 30015 (000Eh) 31005 (03ECh)
			Ch2: 30017 (0010h) 32005 (07D4h)
			Ch3: 30019 (0012h) 33005 (0BBCh)
			Ch4: 30021 (0014h) 34005 (0FA4h)
Remote SV (RSV)	%FS	R	Ch1: 30022 (0015h) 31045 (0414h)
			Ch2: 30023 (0016h) 32045 (07FCh)
			Ch3: 30024 (0017h) 33045 (0BE4h)
			Ch4: 30025 (0018h) 34045 (0FCCh)
Cold junction compensation temperature	degree C (0.1 degree C /1digit)	R	Ch1: 30110 (006Dh) 31016 (03F7h)
			Ch2: 30111 (006Eh) 32016 (07DFh)
			Ch3: 30112 (006Fh) 33016 (0BC7h)
			Ch4: 30113 (0070h) 34016 (0FAFh)
Output value	%	R	Ch1: 30120 (0077h)
			Ch2: 30121 (0078h)
			Ch3: 30122 (0079h)
			Ch4: 30123 (007Ah)
Heater current [A]	A(0.1A/1digit)	R	Ch1: 30071 (0046h) 31046 (0415h)
			Ch2: 30073 (0048h) 32046 (07FDh)
			Ch3: 30075 (004Ah) 33046 (0BE5h)
			Ch4: 30077 (004Ch) 34046 (0FCDh)

4.7 Optional Functions Setting

Parameter	Unit	Attribute	Modbus register number (relative address)
Heater current [B]	A(0.1A/1digit)	R	Ch1: 30072 (0047h) 31047 (0416h)
			Ch2: 30074 (0049h) 32047 (07FEh)
			Ch3: 30076 (004Bh) 33047 (0BE6h)
			Ch4: 30078 (004Dh) 34047 (0FCEh)
Leak current [A]	A(0.1A/1digit)	R	Ch1: 30081 (0050h) 31048 (0417h)
			Ch2: 30083 (0052h) 32048 (07FFh)
			Ch3: 30085 (0054h) 33048 (0BE7h)
			Ch4: 30087 (0056h) 34048 (0FCFh)
Leak current [B]	A(0.1A/1digit)	R	Ch1: 30082 (0051h) 31049 (0418h)
			Ch2: 30084 (0053h) 32049 (0800h)
			Ch3: 30086 (0055h) 33049 (0BE8h)
			Ch4: 30088 (0057h) 34049 (0FD0h)
Error source display	None	R	Ch1: 31008 (03EFh)
			Ch2: 32008 (07D7h)
			Ch3: 33008 (0BBFh)
			Ch4: 34008 (0FA7h)
Alarm 1-5 status	None	R	Ch1: 31007 (03EEh)
			Ch2: 32007 (07D6h)
			Ch3: 33007 (0BBEh)
			Ch4: 34007 (0FA6h)
Event input status	None	R	Ch1: 31061 (0424h)
			Ch2: 32061 (080Ch)
			Ch3: 33061 (0BF4h)
			Ch4: 34061 (0FDCh)

Parameter	Unit	Attribute	Modbus register number (relative address)
Remaining time on timer 1	min:sec. / hr:min.	R	Ch1: 31011 (03F2h)
			Ch2: 32011 (07DAh)
			Ch3: 33011 (0BC2h)
			Ch4: 34011 (0FAAh)
Remaining time on timer 2	min:sec. / hr:min.	R	Ch1: 31012 (03F3h)
			Ch2: 32012 (07DBh)
			Ch3: 33012 (0BC3h)
			Ch4: 34012 (0FABh)
Remaining time on timer 3	min:sec. / hr:min.	R	Ch1: 31013 (03F4h)
			Ch2: 32013 (07DCh)
			Ch3: 33013 (0BC4h)
			Ch4: 34013 (0FACH)
Remaining time on timer 4	min:sec. / hr:min.	R	Ch1: 31014 (03F5h)
			Ch2: 32014 (07DDh)
			Ch3: 33014 (0BC5h)
			Ch4: 34014 (0FADh)
Remaining time on timer 5	min:sec. / hr:min.	R	Ch1: 31015 (03F6h)
			Ch2: 32015 (07DEh)
			Ch3: 33015 (0BC6h)
			Ch4: 34015 (0FAEh)

Explanation on parameters

- Measurement value (PV)

The current input value is stored (See "PV input basic setting" [▶▶ 4-15](#))

- Set value (SV)

The currently controlled set value is stored. In Local operation, SV value [▶▶ 4-4](#) is stored and in Remote operation mode, Remote SV input value [▶▶ 4-22](#) is stored.

- DV

The difference between PV and SV is stored. (DV=PV-SV)

- Output value (MV1)

The current output value is stored. In single control, the PID calculated result is stored and in heating/cooling control, the output value of the heating output side is stored.

4.7 Optional Functions Setting

- Output value (MV2)
in heating/cooling control , the current output value of the cooling output side is stored. In single control, always the output value of MV2 lower limits is stored. ▶▶ 4-49

- Remote SV (RSV)
The Remote SV input value ▶▶ 4-22 is stored. The Remote SV input value can be monitored in local mode also.

- Cold junction compensation temperature
When “Cold junction compensation” ▶▶ 4-21 is set to “1:ON” , the compensation value which is added to the input value is stored. In the case of thermocouple input only, the valid value is stored.

- Output value
Value of output which is currently output from the output terminal is stored.

- Heater current [A/B]
The current value (when the power is ON) being measured at the CT input terminal is stored.

- Leak current [A/B]
The leak current value (when the power is OFF) being measured at the CT input terminal is stored.

- Error source display
Input error status of PV or Remote SV is stored in bits. When an input error occurred, the corresponding bit turns ON.

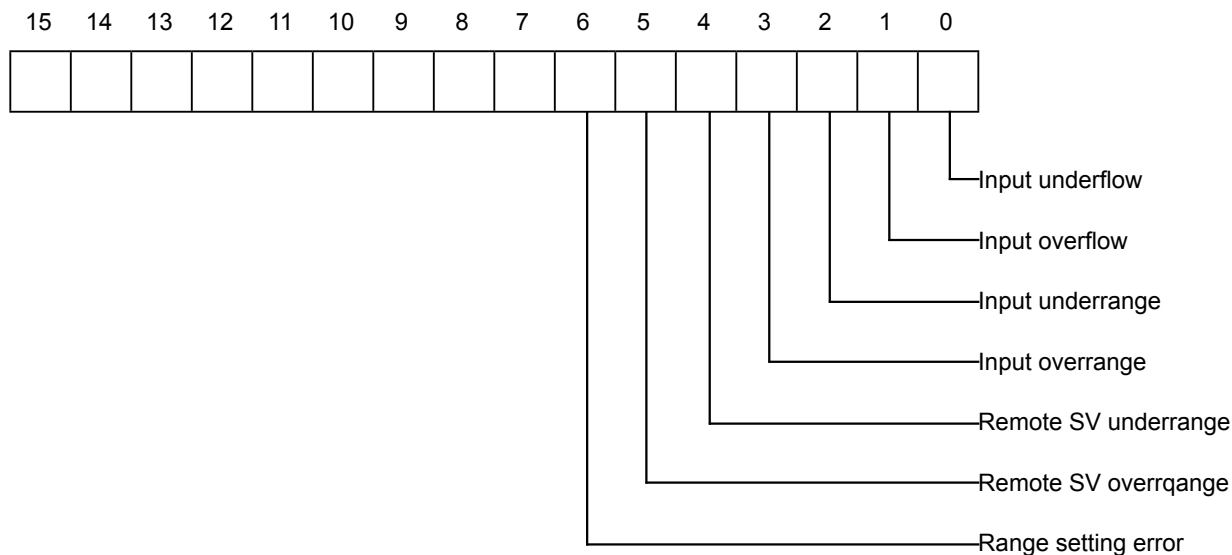

- Alarm 1-5 status

ON/OFF and the output status of alarms is stored in bits. As for high 8 bits, if an error occurred the corresponding bit turns ON. As for low 8 bits, if an alarm output is ON the corresponding bit turns ON.

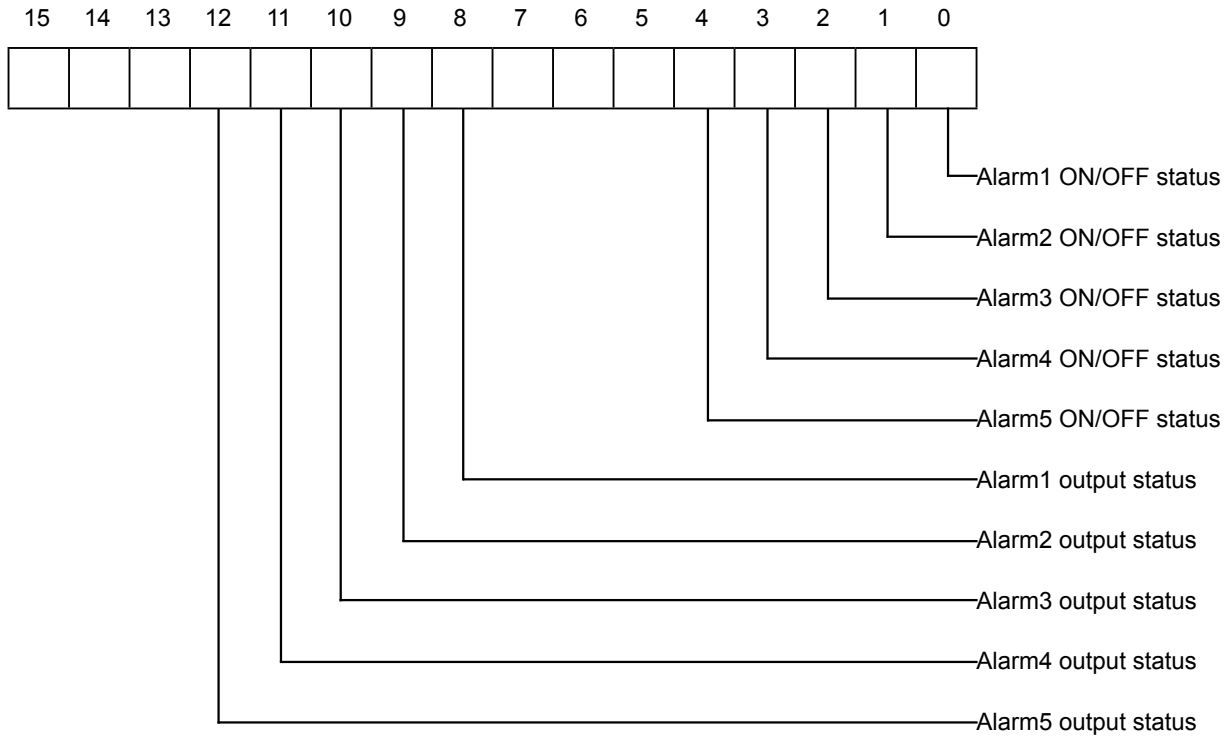

When non-excitation output alarm function is selected for DO option functions setting ▶▶ 4-68, the output status is contrary to Alarm ON/OFF status.

4.7 Optional Functions Setting

- Event input status display

DI input status of event input/output module specified when setting digital input functions [▶▶ 4-88](#) is stored.

When digital input is ON, the corresponding bit turns ON.

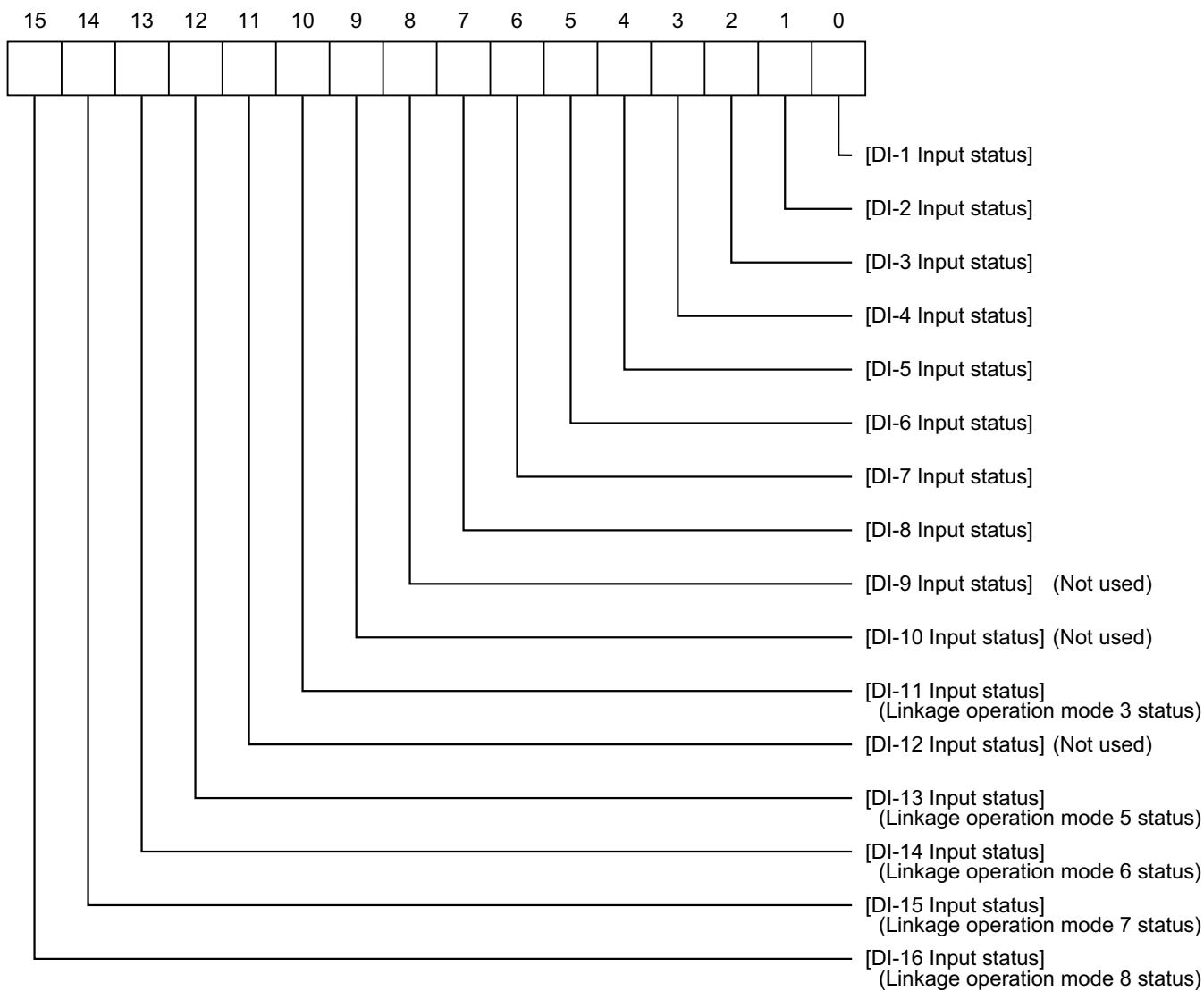

- Remaining time on timer 1/2/3/4/5

Remaining time of delay timer is stored when “DO event type [▶▶ 4-57](#)” is set to “ALM delay time [▶▶ 4-65](#) .”

LED Display Setting

Specifies the lighting conditions of the LED lamps on the front terminal block of this module.

Each module has the parameter shown below.

Parameter	Range	Unit	Factory default	Attribute	Modbus register number (relative address)
LED2 Lamp Allocation	0 to 5	None	1	R/W	40222 (00DDh)
LED3 Lamp Allocation	0,8,12,16,41 to 46, 50 to 58	None	12	R/W	40223 (00DEh)
LED4 Lamp Allocation	0,9,13,17,71 to 76, 80 to 88	None	13	R/W	40224 (00DFh)
LED5 Lamp Allocation	0,10,14,18,101 to 106, 110 to 118	None	14	R/W	40225 (00E0h)
LED6 Lamp Allocation	0,11,15,19,131 to 136, 140 to 148	None	15	R/W	40226 (00E1h)

LED Lamps

On the front terminal block, there are 6 LED lamps which are from the top; "LED1", "LED2", "LED3", "LED4", "LED5", and "LED6" to indicate the operation state of this module. According to the state of this module, the lamps illuminate as shown below.

Operation State	LED Lamp					
	LED1	LED2	LED3	LED4	LED5	LED6
Start up	Green light ON *1					
After initial processing						
Normal processing	Green light ON *1	Operates to the designated lighting condition.				
Communication error	Red light ON	Operates to the designated lighting condition.				
Input error (Unit minor failure)	Red light blinking	Operates to the designated lighting condition.				

*1 If the module is set as the master module for intermodule communication, the green light blinks.

LED lighting condition setting

Lighting conditions can be set to all of the lamps except "LED1."

– "LED2" lamp lighting condition setting

Lighting Condition	LED Color	Set Value
None	Light OFF	0
RS485 Communication state	While receiving	1
	While transmitting	
All channels Standby *1	Green	2
All channels error input state *1	Orange	3
All channels Auto-tuning *1	Green	4
All channels DO output *1	Orange	5

*1 LED lamp will be illuminated if any channel applies to the condition.

– "LED3" to "LED6" lamp lighting condition setting

Lighting condition	LED color	Set value			
		LED3	LED4	LED5	LED6
None	Light OFF	0	0	0	0
Being output *1	Green	8	9	10	11
Being output / Error input	Green/ Red *2	12	13	14	15
DO 1 to DO8 output *3	Red	16	17	18	19
Error input	Red	41	71	101	131
Manual mode	Green	42	72	102	132
Standby	Green	43	73	103	133
Remote mode	Green	44	74	104	134
Soft start	Green	45	75	105	135
Ramp SV	Green	46	76	106	136
Auto-tuning	Green	50	80	110	140
DO1 output	Red	51	81	111	141
DO2 output	Red	52	82	112	142
DO3 output	Red	53	83	113	143
DO4 output	Red	54	84	114	144
DO5 output	Red	55	85	115	145

*1 With relay output or SSR drive output type, LED lamps illuminate when output is switched ON. With current output type, LED lamps remain OFF.

*2 LED lamps will illuminate as shown below according to the status of input error and control output.

		Input error status	
		Abnormal	Normal
Control output	ON	Red light ON	Green light ON
	OFF	Red light ON	Light OFF

*3 LED lamps illuminate if any of DO1 to DO5 output has been switched ON.

User Address Specification Communication RST

Random addresses can be set to the user address area. Maximum 32 addresses can be registered.

The relative parameters are as shown below.

Parameter	Range	Unit	Factory default	Attribute	Modbus register number (relative address)
User address 01: Register number specification	30001 to 44999	None	30002	R/W	40301 (012Ch)
to					
User address 32: Register number specification	30001 to 44999	None	30002	R/W	40332 (014Bh)
User data 01: (R/W area)	Depends on "User address 01"				45001 (1388h)
to					
User data 32: (R/W area)	Depends on "User address 32"				45032 (13A7h)

The addresses specified for "User address 01 to 32" can be used for the corresponding "User data 01 to 32."

Random or nonconsecutive addresses can be treated as successive areas by using "User data 01 to 32" parameters.

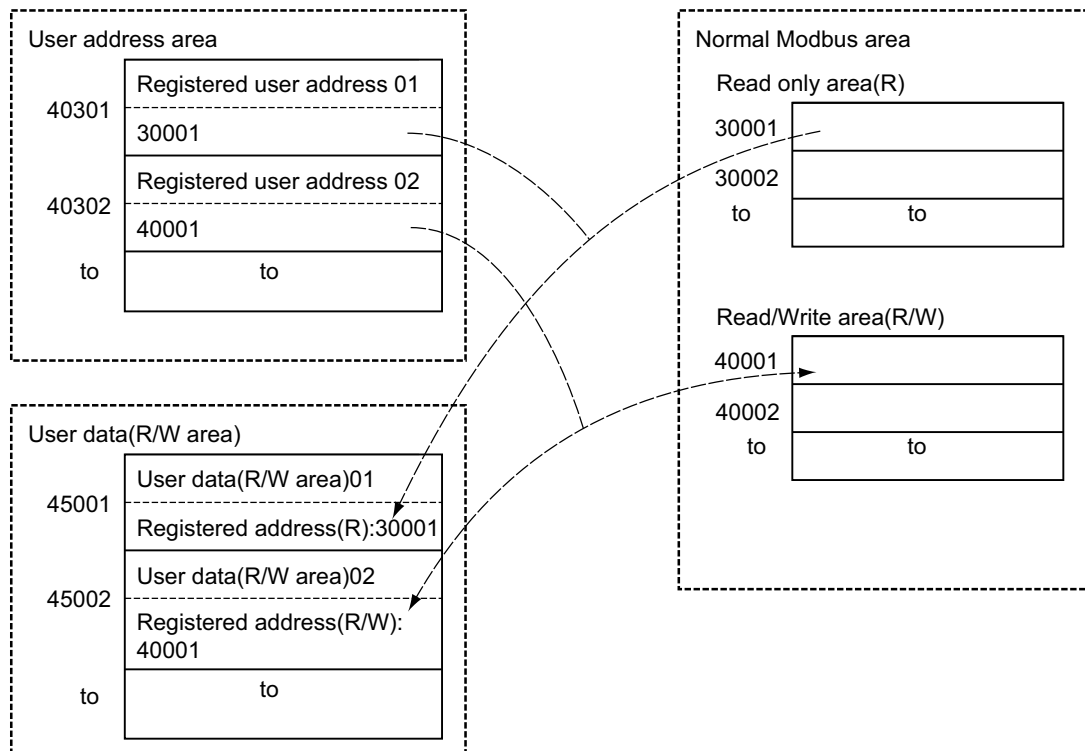

Note

- If an abnormal Modbus address is set as "User address", it cannot read or write data using "User data (R/W area).
- If a Modbus address of Read only area is set as "User address", it cannot write data to the corresponding "User data (R/W area)."

Reset Main Unit

Resets (restarts) the main unit.

The relative parameter is as shown below.

Parameter	Range	Unit	Factory default	Attribute	Modbus register number (relative address)
Reset main unit	0: Do nothing 1: Reset main unit	None	0	R/W	40101 (0064h)

The main unit is reset if this parameter is set to ("1: Reset main unit"). As "Reset main unit" is the same operation as supplying the power to the main unit, changed parameters which requires restarting of the main unit can be reflected without doing so.

Point

 mark is on the parameters which requires restarting of the main unit after setting change.

5

Communication

5.1	Communication Functions	5-3
5.2	Communication Specifications	5-5
5.3	Connection	5-7
5.4	Setting Communication Parameters	5-10
5.5	Modbus RTU Communication Protocol.....	5-12
5.6	Command and Transmission Frame Details	5-20
5.7	Address Map and data format	5-29
5.8	Sample Program.....	5-51

5.1 Communication Functions

PUM is equipped with communication functions from the RS-485 interface and loader interface, which enables the transmission and reception of data between such devices as the personal computer, programmable controller, and graphic panel.

The communication system is composed of a master and slave relationship. Up to thirty-two slaves (PUMs) may be connected to one master (such as a personal computer) based on a “single master/multiple slave” method.

However, the master can only communicate with one slave at a time. Therefore, each slave is specified by the “Station No.” setting. With loader communication, only one slave can be connected to one master.

Note

- Systems constructed with the PUM as slaves do not respond to messages issued by the master with broadcast queries where the station number is “0”.
- Communication with loader interface should not be attempted during production operation or during RS-485 communication.

In order to have proper communication between master and slave, the transmission data must be in the same format. This document explains how to transmit data using the Modbus RTU protocol format.

When using equipment with an RS-232C interface, such as a personal computer, as the master, make sure to use an RS-232C to RS-485 converter.

When using loader communication, you can use RS-232C communication with the personal computer by connecting the loader interface located on the main unit front face with the loader communication cable (model: PUMZ*L01, optional).

[RS-232C to RS-485 converter] (Recommended)

Model number/Type	Manufacturer	Max. communication speed	URL
KS3C-10	Omron	38.4kbps	http://www.omron.co.jp
RC-770X	Sysmex RA	115.2kbps	http://www.sysmex-ra.co.jp

Connecting to a Programmable Controller

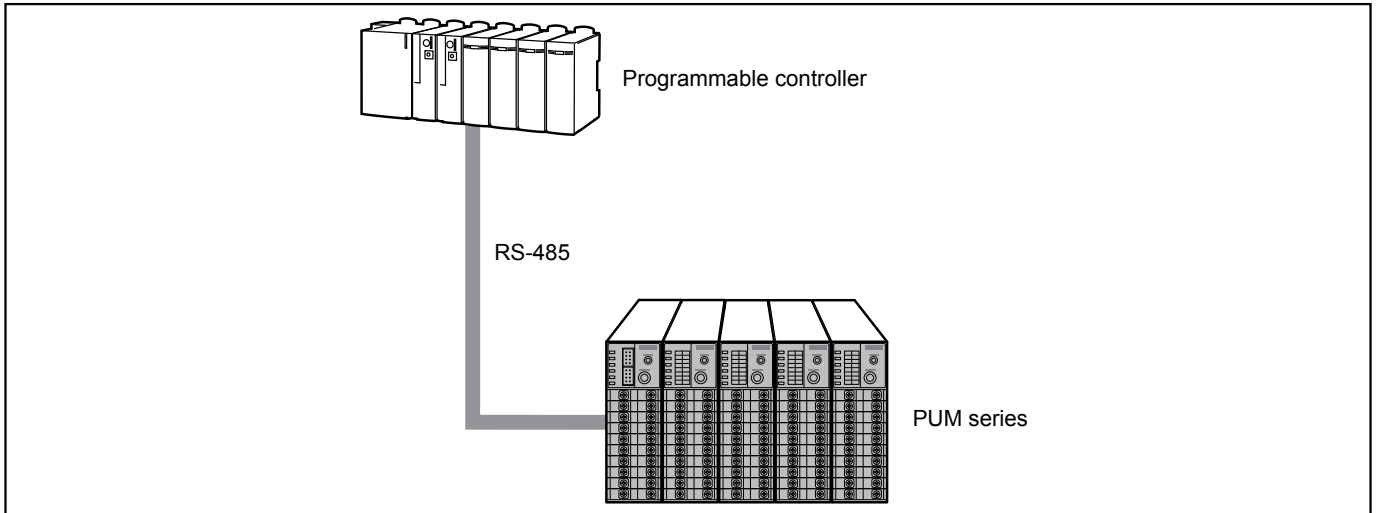

Connecting to a Personal Computer

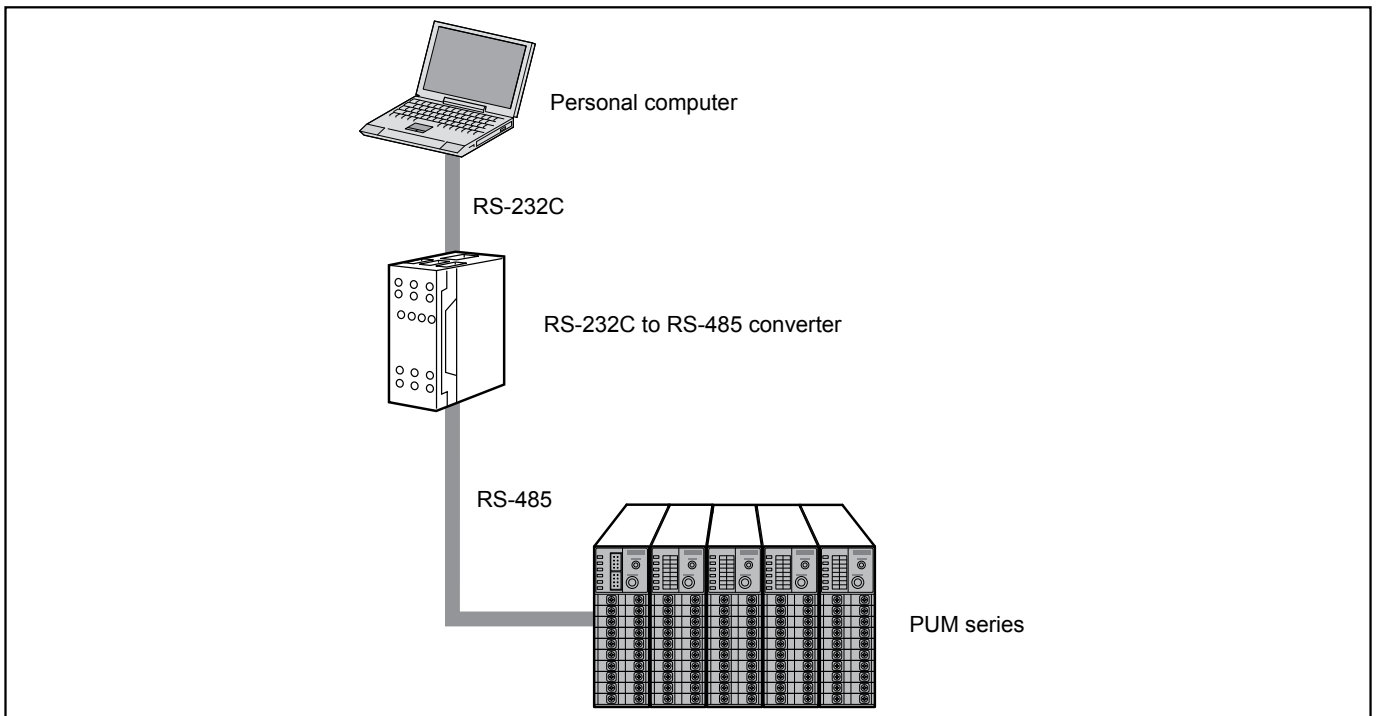

Note

- When using the RS-232C to RS-485 converter, check to make sure that the cable is properly connected between the converter and master.
Communication will not work properly if the connection is incorrect.
- Be sure to correctly set the communication settings (such as communication speed and parity) on the RS-232C to RS-485 converter.
Communication will not work properly if the settings are incorrect.

5.2 Communication Specifications

RS-485

Item	Specifications	
Electrical specifications	EIA RS-485 compliant	
Communication method	2-wire system, half duplex, serial	
Synchronous method	Asynchronous	
Connection status	1 : N	
Max. no. of connections	32 units	
Communication distance	Max 1000m (at 38.4kbps or less), Max 250m (at 115.2kbps)	
Communication speed	9.6kbps, 19.2kbps, 38.4kbps, 115.2kbps	
Data format	Data length	8 bits
	Stop bit	1 bit
	Parity	None/Even/Odd (Selectable)
Transmission code	HEX value (Modbus RTU mode)	
Error detection	CRC-16	
Insulation	No insulation with loader communication port, CT input. Functional insulation with any other input/output.	

Loader Interface

Item	Specifications	
Electrical specifications	EIA RS232C	
Communication method	3-wire system, half duplex, serial	
Synchronous method	Asynchronous	
Connection status	1 : 1	
Station No.	1 to 16	
Communication speed	19.2kbps (Fixed)	
Data format	Data length	8 bits
	Stop bit	1 bit
	Parity	None (Fixed)
Transmission code	HEX value (Modbus RTU mode)	
Error detection	CRC-16	
Insulation	No insulation with RS-485, CT input. Functional insulation with any other input/output.	

5.3 Connection

⚠ Warning

❗ Do not turn on power until all of the wiring is completely finished.
There is a risk of electrical shock or damage.

Assignment of Communication Terminals

RS-485 (terminals on base part)

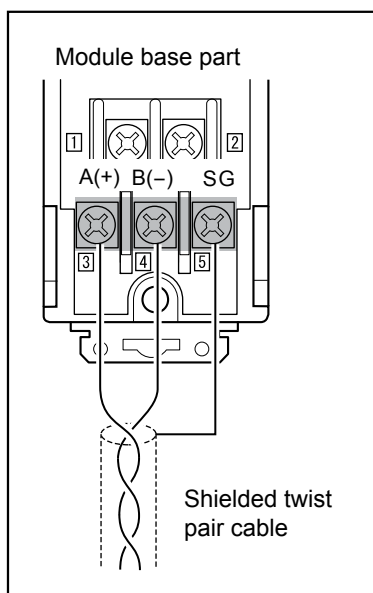

Loader interface (terminals on front face)

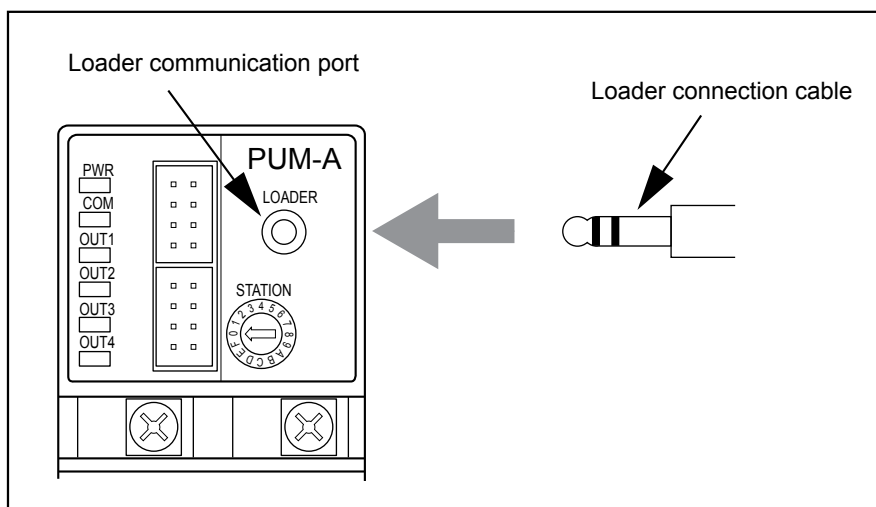

Connection with RS-485

- Please use a shielded twist pair cable. (Recommended cable: KPEV-SB 0.5sq (made by The Furukawa Electric Co., Ltd.))
- The maximum cable length should be 1000m at 38.4kbps or less, 250m at 115.2kbps. One master and up to thirty-two PUMs (slaves) can be connected per circuit.
- Terminate both ends of the circuit with a terminating resistance of 100Ω (1/2W or more).
- Ground the shielded cable once towards the master side.

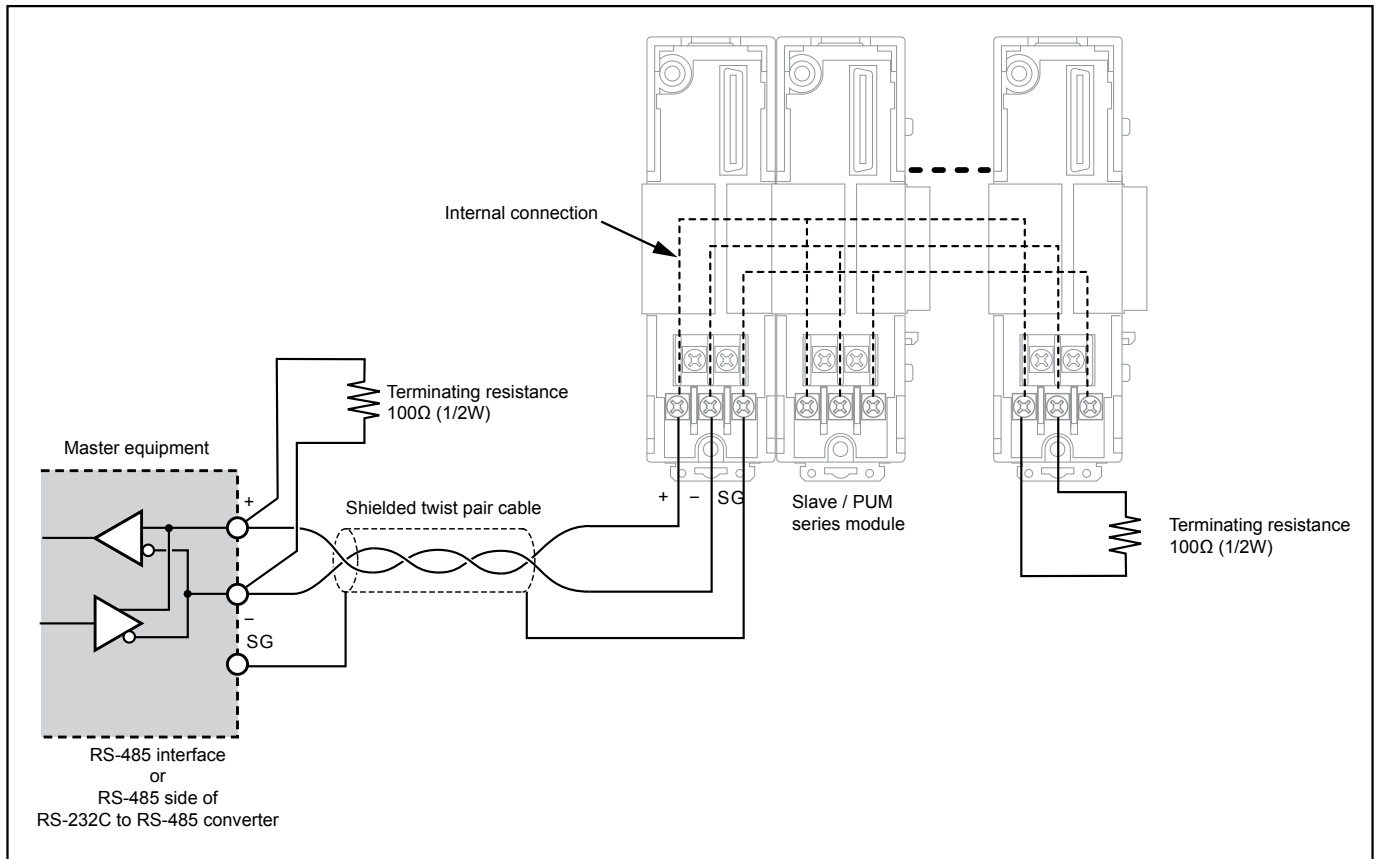

- SG does not have to be connected, but it can be used as an effective countermeasure against communication errors due to noise.
- If there are problems with EMC during communication, the noise level can be reduced by using a communication cable with a ferrite core.

Ferrite core (recommended):

For communication cable : H04SR211132 made by Seiwa Electric MFG. or equivalent

For power cable : E04SR241336A made by Seiwa Electric MFG. or equivalent

Connection with Loader Interface

- Use the loader communication cable (RS-232C) sold separately.

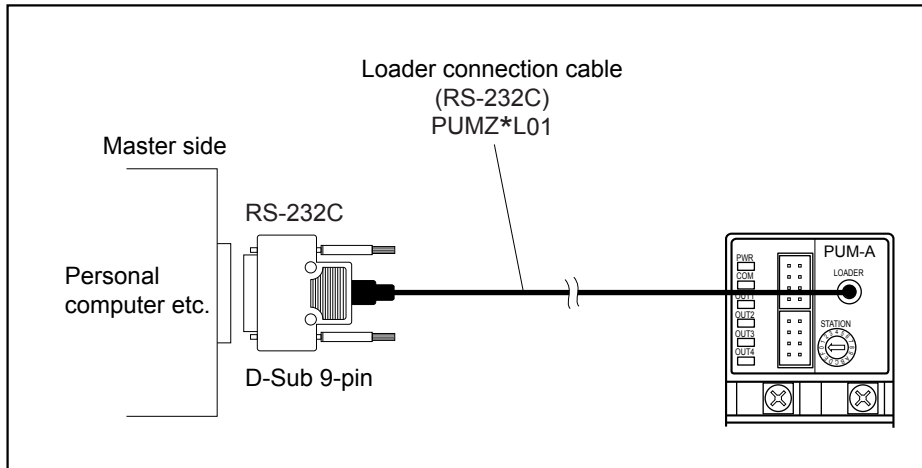

5.4 Setting Communication Parameters

The following settings are required for proper communication between the master and all slaves units (this equipment).

- The communication parameters for the master and all of the units must be set the same.
- All of the slaves on a circuit must be set with different "Station No." other than "0 (zero)". (Multiple PUMs must not have the same "Station No.")

Setup Items for RS-485 (PUM Side)

Parameter (name)	Setup range	Factory default	Remarks
Station number	1 to 16	1	Set value: station number configuration switch No. +1
RS-485 Communication speed	0 (9.6kbps) 1 (19.2kbps) 2 (38.4kbps) 4 (115.2kbps)	1	"3" is forbidden.
RS-485 Parity setting	0 (None) 1 (Odd) 2 (Even)	0	
Data length	8 bits	–	Cannot be changed.
Stop bit	1 bit	–	Cannot be changed.
RS-485 Communication permission	0: Read only 1: Read / Write	1	
RS-485 Response interval time	0 to 25	1	The response interval time can be set by set value x 20 ms.
Enhanced communication module (PUMC) connection	0: PUMC not connected (RS485 Enable) 1: PUMC connected (RS485 Disable)	0	Set at "0" for use of RS-485 communication.

Setup Items on Loader Interface (PUM Side)

Parameter (name)	Setup range	Factory default	Remarks
Station number	0 to Fh (1 to 16)	1	Set value: station number configuration switch No. +1
Communication speed	19.2kbps (fixed)	–	Cannot be changed.
Data length	8 bits	–	Cannot be changed.
Parity	None	–	Cannot be changed.
Stop bit	1 bit	–	Cannot be changed.
Master/slave setting in connected modules	0 (Master) 1 (Slave)	1	Set one as the master and set others as slaves.

5.5 Modbus RTU Communication Protocol

The communication system with the MODBUS protocol always operates using a method where the master first sends a command message and the applicable slave replies with a response message.

The following describes the communication steps.

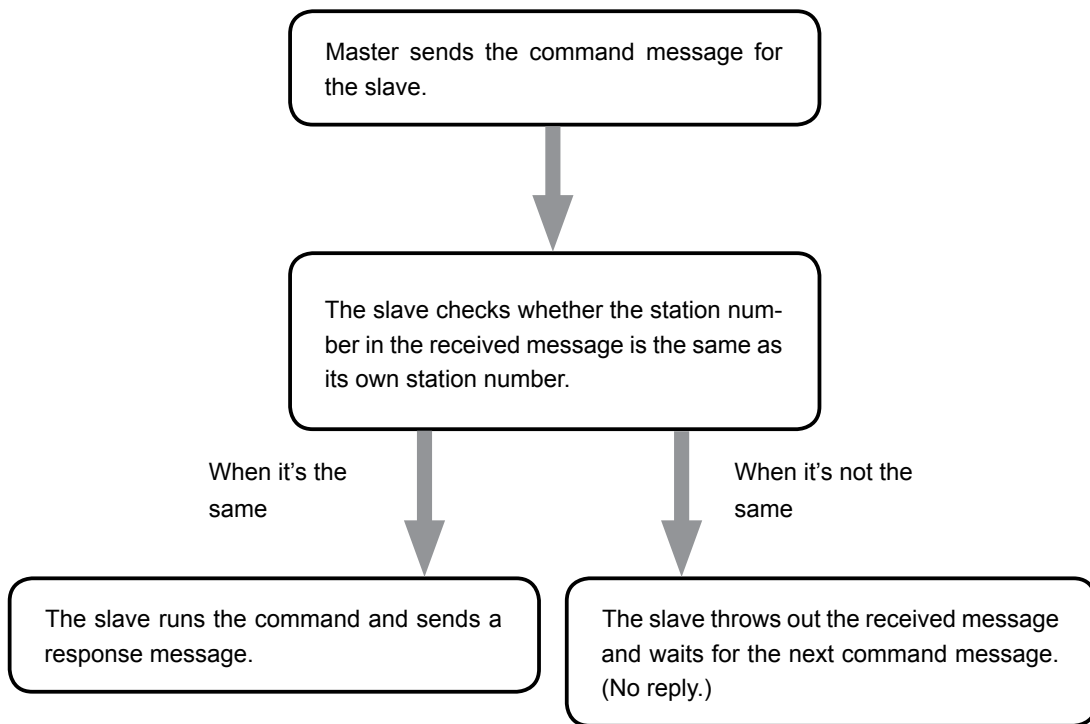

When the station number in the command message is the same as the unit's station number

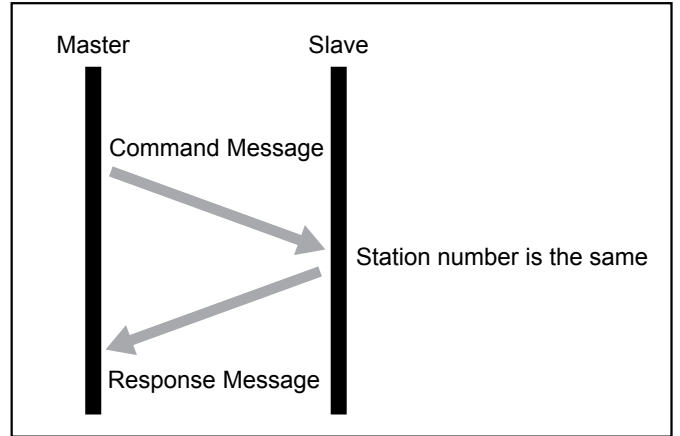

When the station number in the command message is not the same as the unit's station number

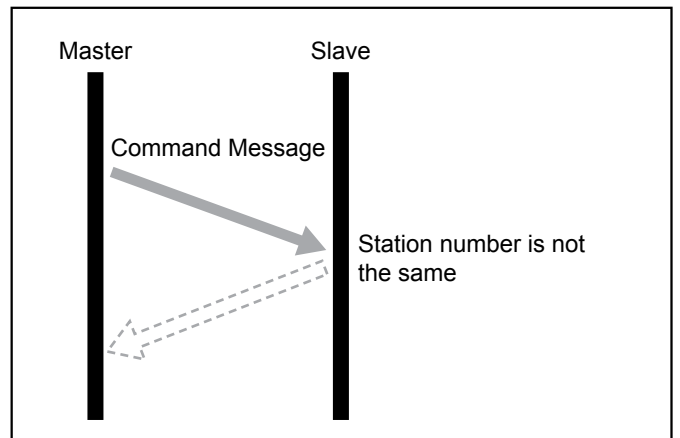

Point

The master can communicate with an individual slave when multiple slaves are connected on the same circuit by the station number specified in the master's command message.

Message Composition

The command message and response message are composed of four parts: the station number, function code, data part, and error check code. These four parts are sent in that order.

Field name	Number of bytes
Station No.	1 byte
Function code	1 byte
Data part	2 to 64 bytes
Error check code (CRC-16)	2 bytes

Station No.

This is the number specifying the slave. Commands can only be processed by slaves that have the same value set with the station number configuration switch (setting position + 1) located on the terminal block on the front face .

Function Code

This code specifies the function for the slave to perform.

Data Part

This data is required to run the function code. The composition of the data part is different depending on the function code.

The data in the PUM is assigned a coil number or register number. This coil number or register number is specified when the data is read or written through communication.

The coil number or register number used by the message employs a relative address.

The relative address is calculated using the following formula.

$$\text{Relative address} = (\text{last 4 digits of the coil number or register number}) - 1$$

(Ex.) When a function code specifies register number "40003"

$$\begin{aligned}\text{Relative address} &= (\text{the last four digits of 40003}) - 1 \\ &= 0002\end{aligned}$$

is used in the message.

Error Check Code

This code detects whether there are errors (changes in the bits) during the signal transmission processes. MODBUS protocol (RTU mode) uses CRC-16 (Cyclic Redundancy Check).

Slave Response

• Normal Slave Response

The slave creates and replies with a response message for each command message. The response message has the same format as the command message.

The contents of the data part are different depending on the function code.

• Irregular Slave Response

If there are problems (such as specification of a nonexistent function code) with the contents of the command message other than transmission error, the slave creates and replies with an error response message without following the command.

The composition of the error response message uses the value of the function code in the command message plus 80H, as seen below.

Field name	Number of bytes
Station No.	1 byte
Function code + 80H	1 byte
Error Code	1 byte
Error check code (CRC-16)	2 bytes

The error code is shown as follows.

Error Code	Contents	Explanation
01H	Faulty function code	A nonexistent function code was specified. Please check the function code.
02H	Faulty address for coil or register	The specified relative address for the coil number or register number cannot be used by the specified function code.
03H	Faulty coil number, register number or data limit.	The specified number is too large and specifies a range that does not contain coil numbers or register numbers. Furthermore, the specified data value is beyond the limit that is set in the specified parameter.
06H	Busy state	Data is being written to the internal memory. Wait 100 msec or more before retrying communication.

• No Response

In the following situations, the slave will ignore the command message and not send a response message.

- The station number specified by the command message is not the same as the slave's specified station number.
- The error check code does not correspond, or a transmission error (such as parity error) is detected.
- The interval between the data comprising the message is empty for more than 24 bit time.

Function Code

For MODBUS protocol, coil numbers or register numbers are assigned by the function code, and each function code only works for the assigned coil number or register number.

The correspondence between the function code and the coil number or register number is as follows.

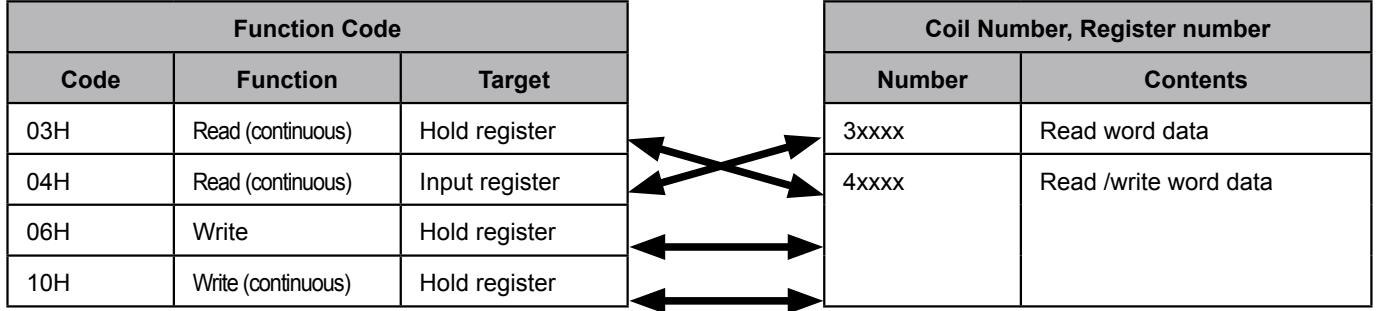

The message length for each function is as follows.

Code	Contents	Assignable Data Number	Command Message		Response Message	
			Minimum	Maximum	Minimum	Maximum
03H	Read word data	32 words *	8 bytes	8 bytes	7 bytes	69 bytes
04H	Read word data (Read only)	32 words *	8 bytes	8 bytes	7 bytes	69 bytes
06H	Write word data	1 word	8 bytes	8 bytes	8 bytes	8 bytes
10H	Continuously write word data	32 words *	11 bytes	73 bytes	8 bytes	8 bytes

* : "Assignable Data Number" above is limited by the data number that the PUM assigned to the coil number or register number. (Excluding function code 06H).

Calculating Error Check Code (CRC-16)

CRC-16 is a 2-byte (16-bit) error check code.

The calculation range extends from the start of the message (station number) to the end of the data part.

The slave calculates the CRC of the received message and ignores the message if this value is not the same as the received CRC code.

CRC-16 is calculated as follows.

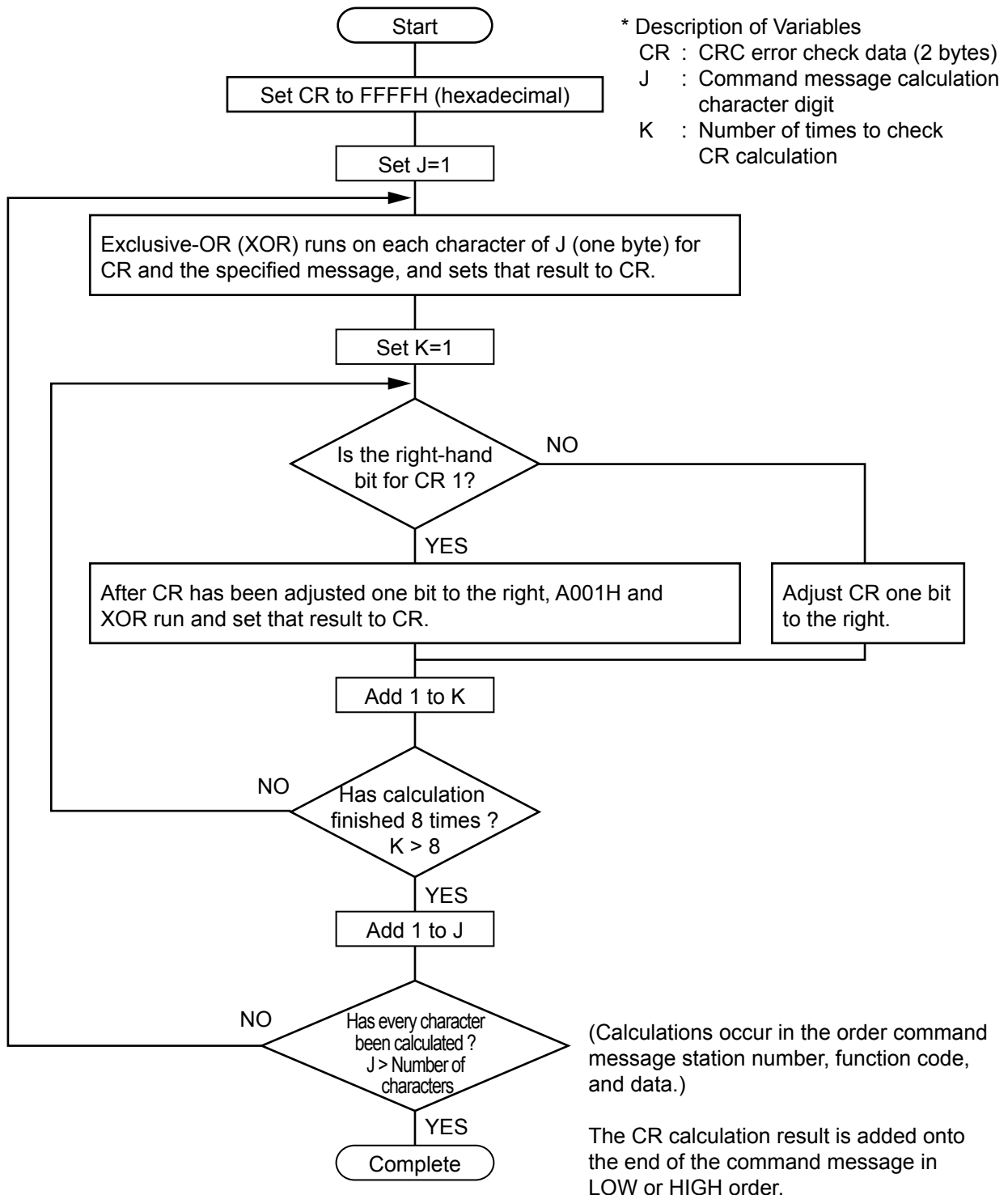

Transmission Control Steps

Master Communication Method

Start communication from the master while following the rules below.

1. The command message, must be sent after an empty space of at least 48 bits time.
2. The interval between each byte in a command message should be less than 24 bits time.
3. After sending a command message, for less than 24 bits time the master will enter receiving standby.
4. After receiving the response message, the next command message must be sent after at least 48 bits time. (Similar to 1 above.)
5. For safety reasons, create a framework where the master checks the response message, and if there is no response or an error occurs, retry at least three times.

Note

The definitions written above are for the minimum required value. For safety reasons, we recommend creating a master side program that keeps margins two to three times as large. For a concrete example, with 19.2kbps, we recommend programming a blank state (1 above) of at least 10ms, and the interval between bytes (2 above) and switching time from sending to receiving (3 above) within 1 ms.

Frame Detection

This communication system uses a two-wire RS-485 interface, and the circuit can therefore enter one of the following two states.

- Empty state (no data on the circuit)
- Communication state (data running on the circuit)

The units connected on the circuit start in receiving state and monitor the circuit. When a blank state appears on the circuit for at least 24 bits time, the unit detects the end of the previous frame, and within the next 24 bits time, enters receiving standby. When data appears on the circuit, the unit begins receiving data, and once another blank state of at least 24 bits time is detected, that frame is ended. In other words, the data on the circuit from the first time that a 24 bits time blank state appears to the second time one appears is loaded as one frame (a bundle of data). Therefore, one frame (command message) must be sent while following the rules below.

- Before sending the command message, leave an empty space of at least 48 bits time.
- The interval between each byte in a command message should be less than 24 bits time.

PUM Response

After the PUM detects the frame (detects blank states at least 24 bits time long), that frame is used to send a command message. When a command message is sent locally, the response message is returned, but the processing time is about 1 to 30 ms. (The time may change depending on the contents of the command message.) Therefore, one frame (command message) must be sent while following the rules below.

- After sending a command message, for less than 24 seconds the master will enter receiving standby.

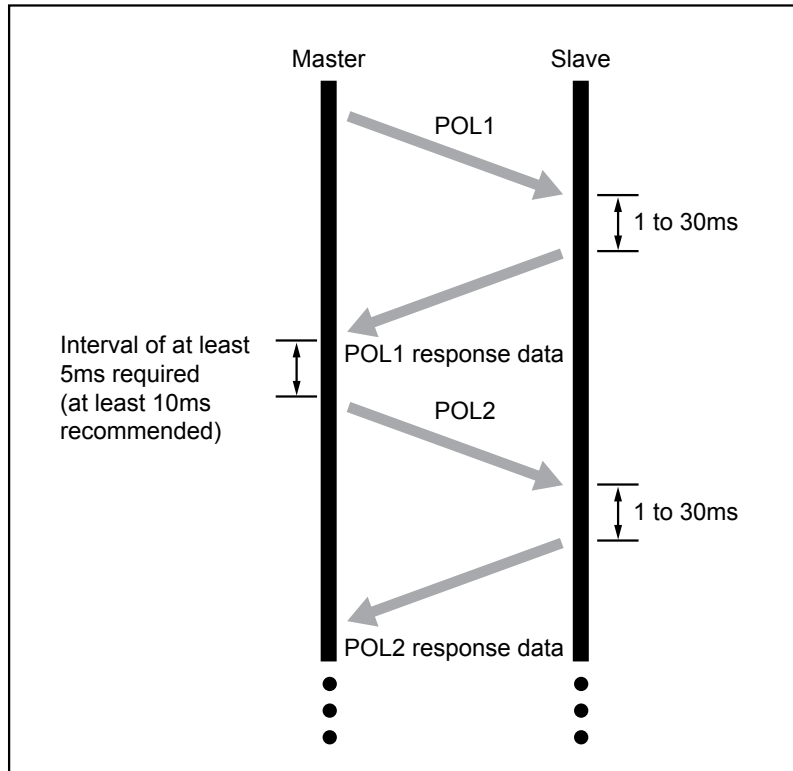

5.6 Command and Transmission Frame Details

Reading Data

Reading Word Data (Function Code: 03H)

The unit reads word data continuously for the specified number of words from the first number to start reading from.

The slave forwards the read word data from the upper number of bytes to the lower number.

Function Code	03H
Max. No. of Words to Read in One Message	32
Relative Address	0000H to 13A7H
Register Number	40001 to 45032

• Message Composition

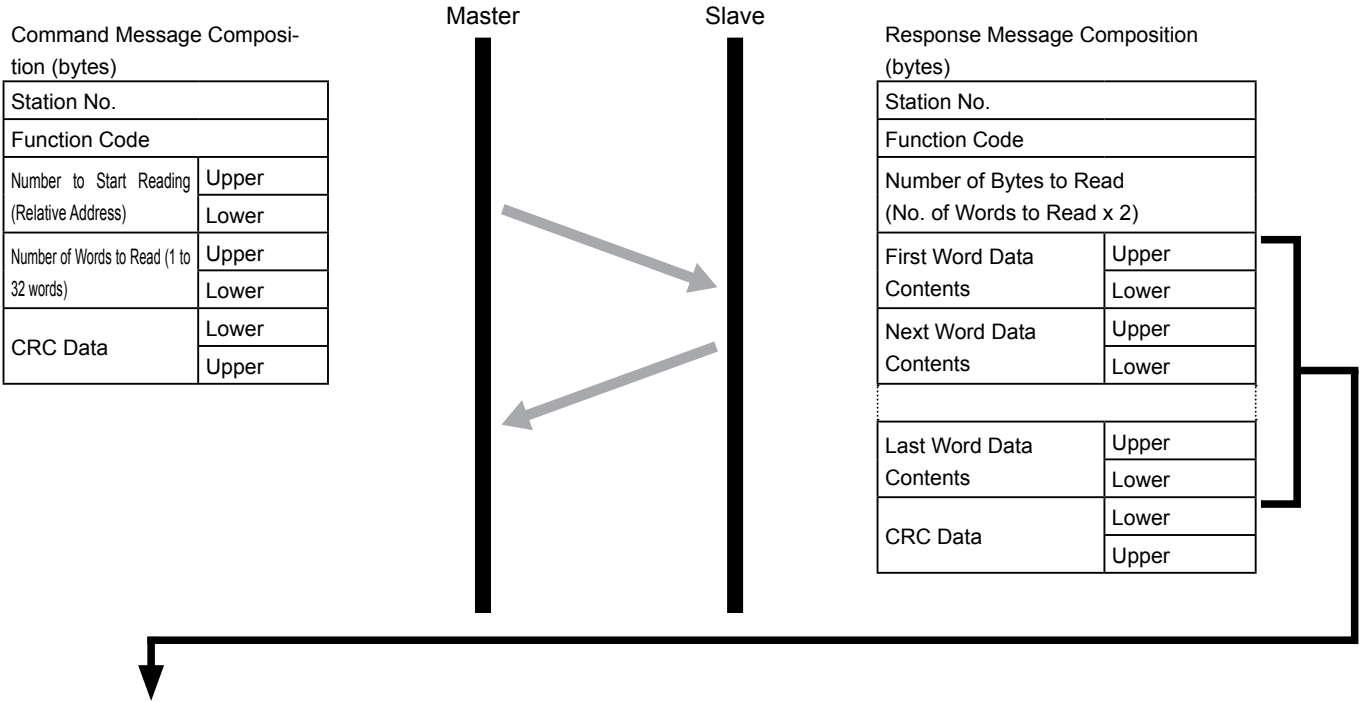

Meaning of Read Word Data

MSB	LSB
First Word Data Contents upper byte	
First Word Data Contents lower byte	
Next Word Data Contents upper byte	
Next Word Data Contents lower byte	
...	
Last Word Data Contents upper byte	
Last Word Data Contents lower byte	

5.6 Command and Transmission Frame Details

- **Example of Transmitting a Message**

The message composition is as shown below in case of readout of PV input lower limit and PV input upper limit from Ch1 of station number 2.

- **Relative Address of “PV Lower Limit Relative Address” : 04BBH**

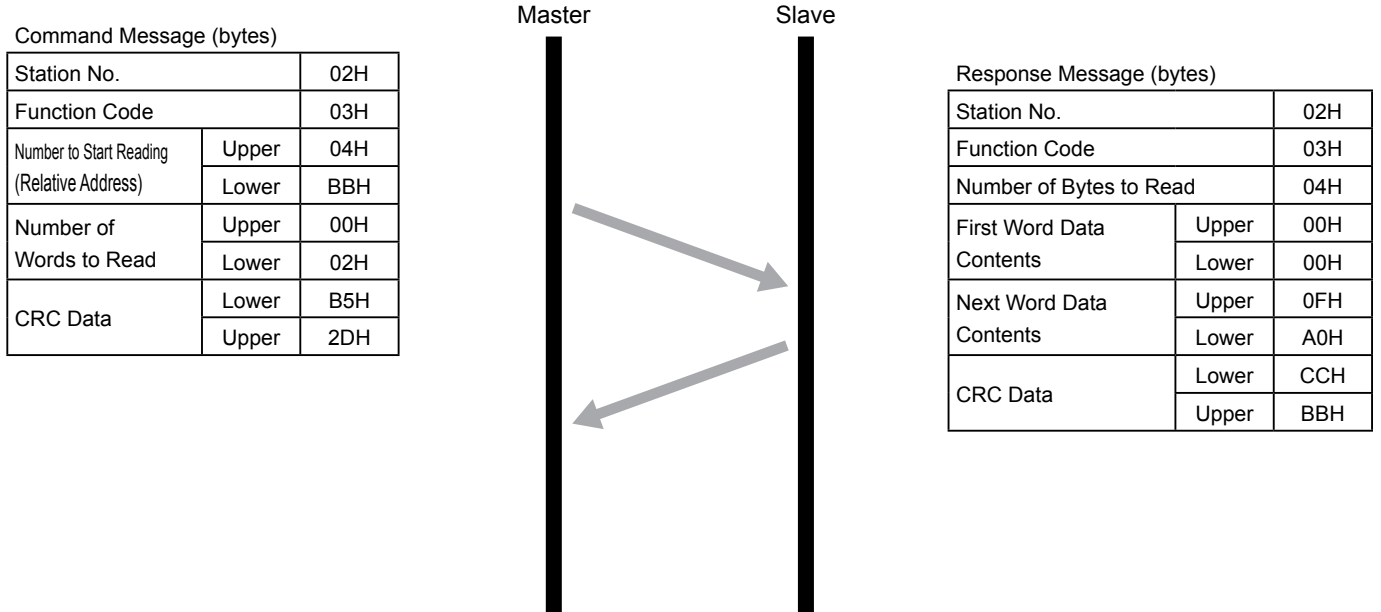

Meaning of Read Data

PV Input Lower Limit 0000H = 0

PV Input Upper Limit 0FA0H = 4000

If decimal Point Position = 0, then the PV input upper limit and lower limit are as follows.

PV Input Lower Limit = 0.0 °C

PV Input Upper Limit = 400.0 °C

Point

The decimal point cannot be included in transmission data, so data such as [400.0] is transmitted as [4000].

Reading Read-Only Word Data (Function Code: 04H)

The unit reads word data continuously for the specified number of words from the first number to start reading from. The slave forwards the read word data from the upper number of bytes to the lower number.

Function Code	04H
Max. Number of Words to Read in One Message	32
Relative Address	0000H to 0FDGH
Register Number	30001 to 34061

• **Message Composition**

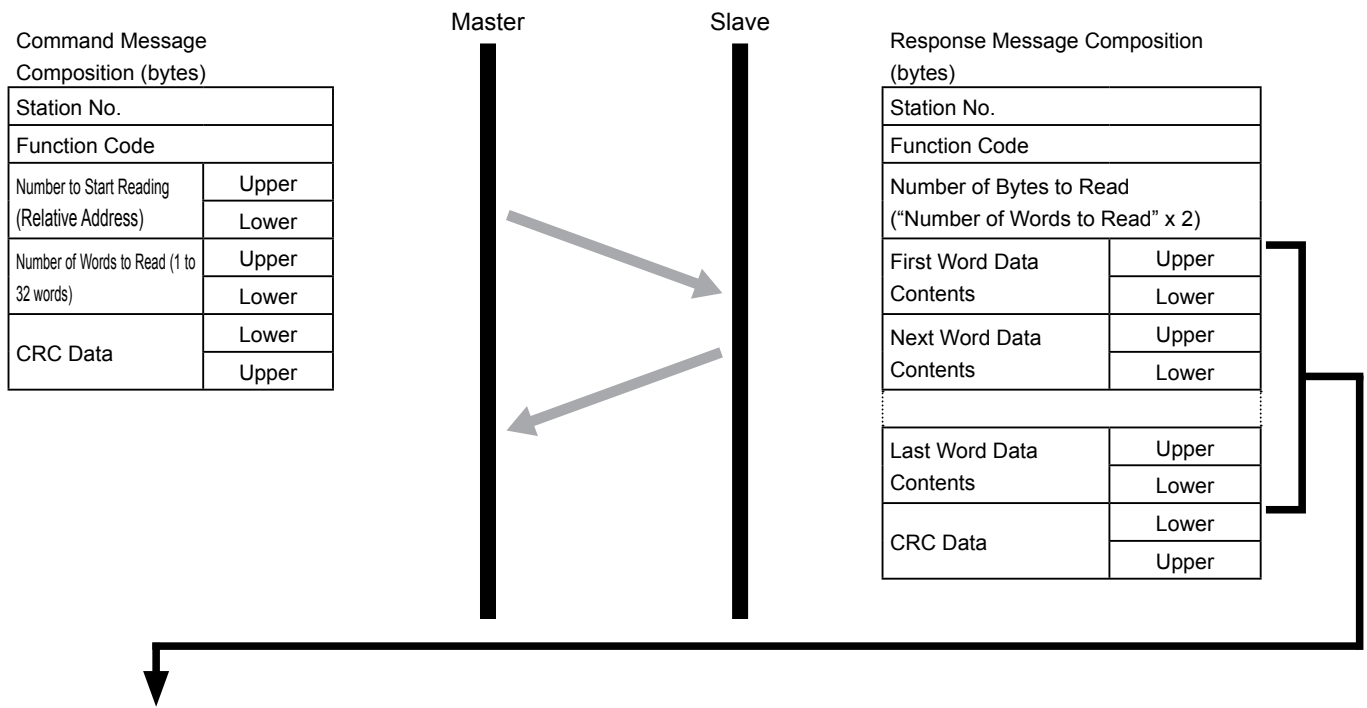

Meaning of Read Word Data

MSB	LSB
First Word Data Contents upper byte	
First Word Data Contents lower byte	
Next Word Data Contents upper byte	
Next Word Data Contents lower byte	
.....	
Last Word Data Contents upper byte	
Last Word Data Contents lower byte	

5.6 Command and Transmission Frame Details

- **Example of Transmitting a Message**

The message composition is as shown below in case of readout of PV value from Ch1 of station number 1.

- **Relative address of “PV value” : 0001H, Number of data:01H**

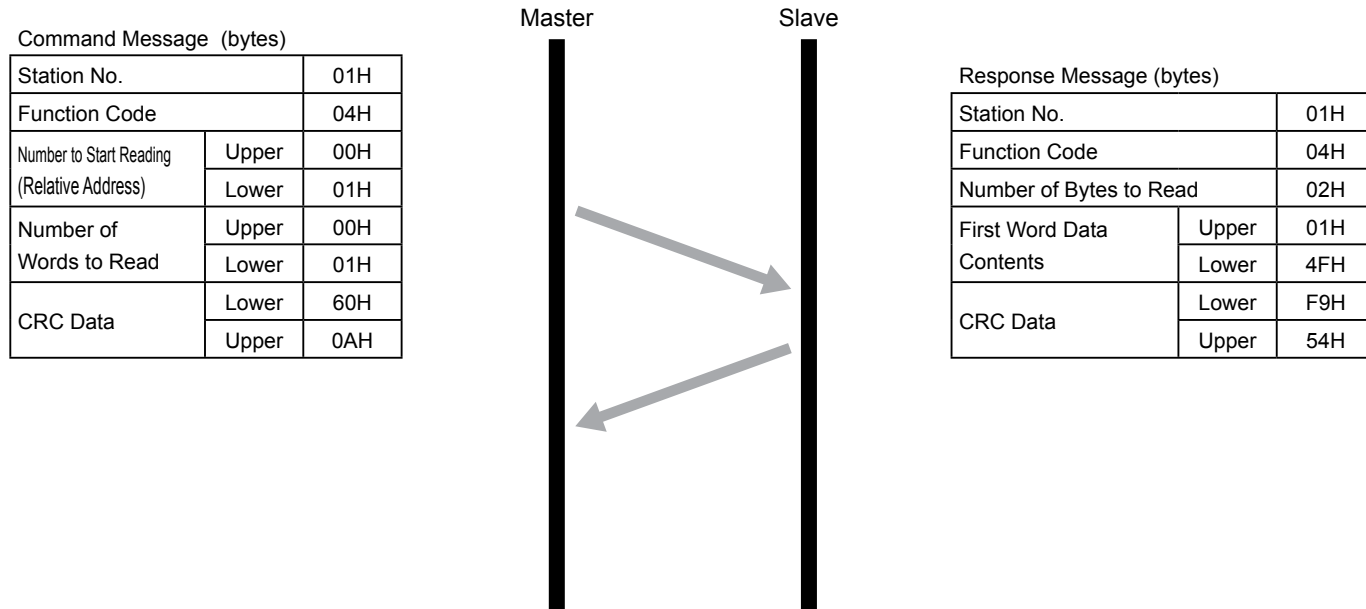

Meaning of Read Data

Word Data Contents 014FH=335

In case decimal point position = 1;

PV = 33.5 °C

Writing Data

Writing word Data (1 word, function code: 06H)

This writes the specified data to the specified number for word data. The master sends the data to be written from the upper number of bytes to the lower number.

Function Code	06H
Max. Number of Words to Write in One Message	1
Relative Address	0000H to 13A7H
Register Number	40001 to 45032

Caution

Do not write data to a address (register number) that is not described in MODBUS address map. (It may cause the malfunction.)

• Message Composition

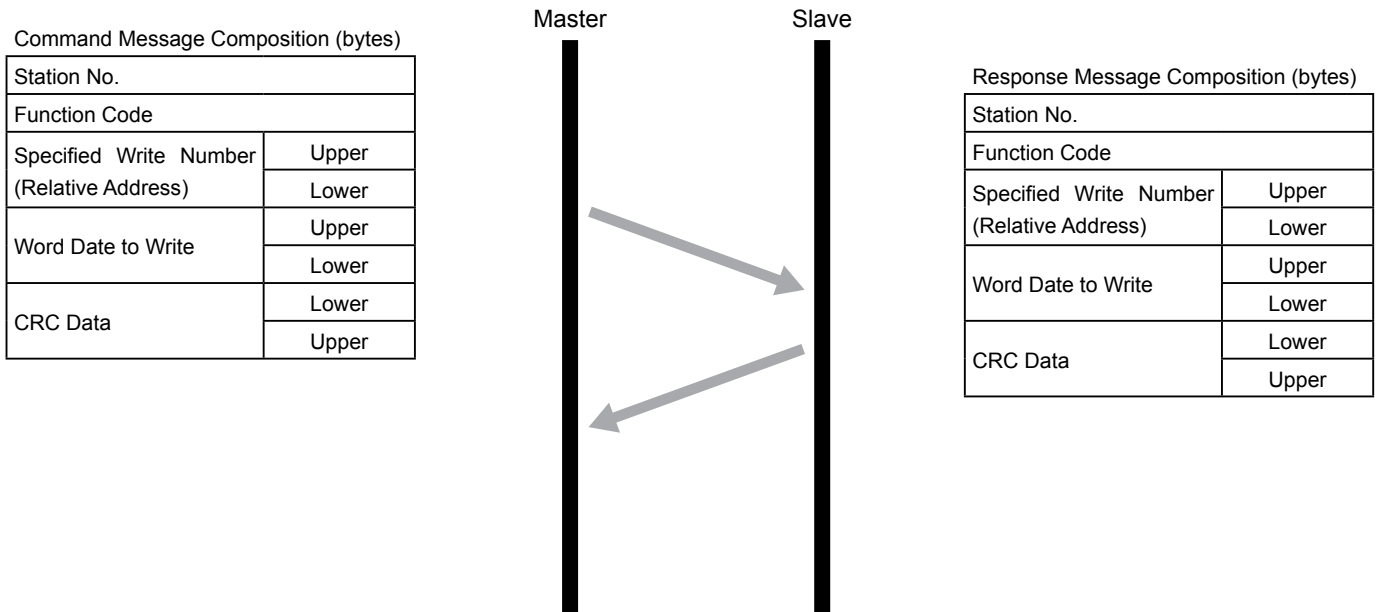

5.6 Command and Transmission Frame Details

- **Example of Transmitting a Message**

A case where parameter “proportional band [P]” of Ch1 of station number 1 is set as 100.0 (1000D=03E8H) is described below as an example.

- **Relative address of “proportional band [P]” : 044DH**

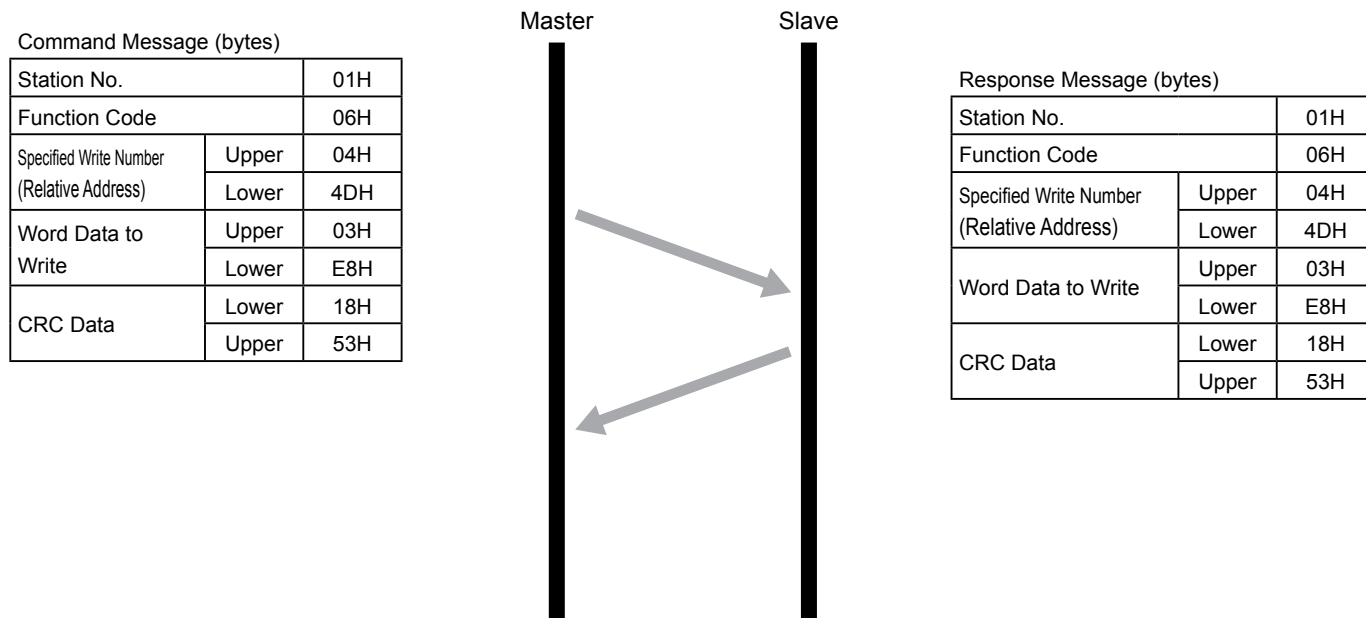

Writing Continuous Word Data (function code: 10H)

This writes continuous word information for a number of written words from the first number for writing.

The master sends the data to be written from the upper number of bytes to the lower number.

Function Code	10H
Max. Number of Words to Write in One Message	32
Relative Address	0000H to 13A7H
Register Number	40001 to 45032

Caution

Do not write data to a address (register number) that is not described in MODBUS address map. (It may cause the malfunction.)

• **Message Composition**

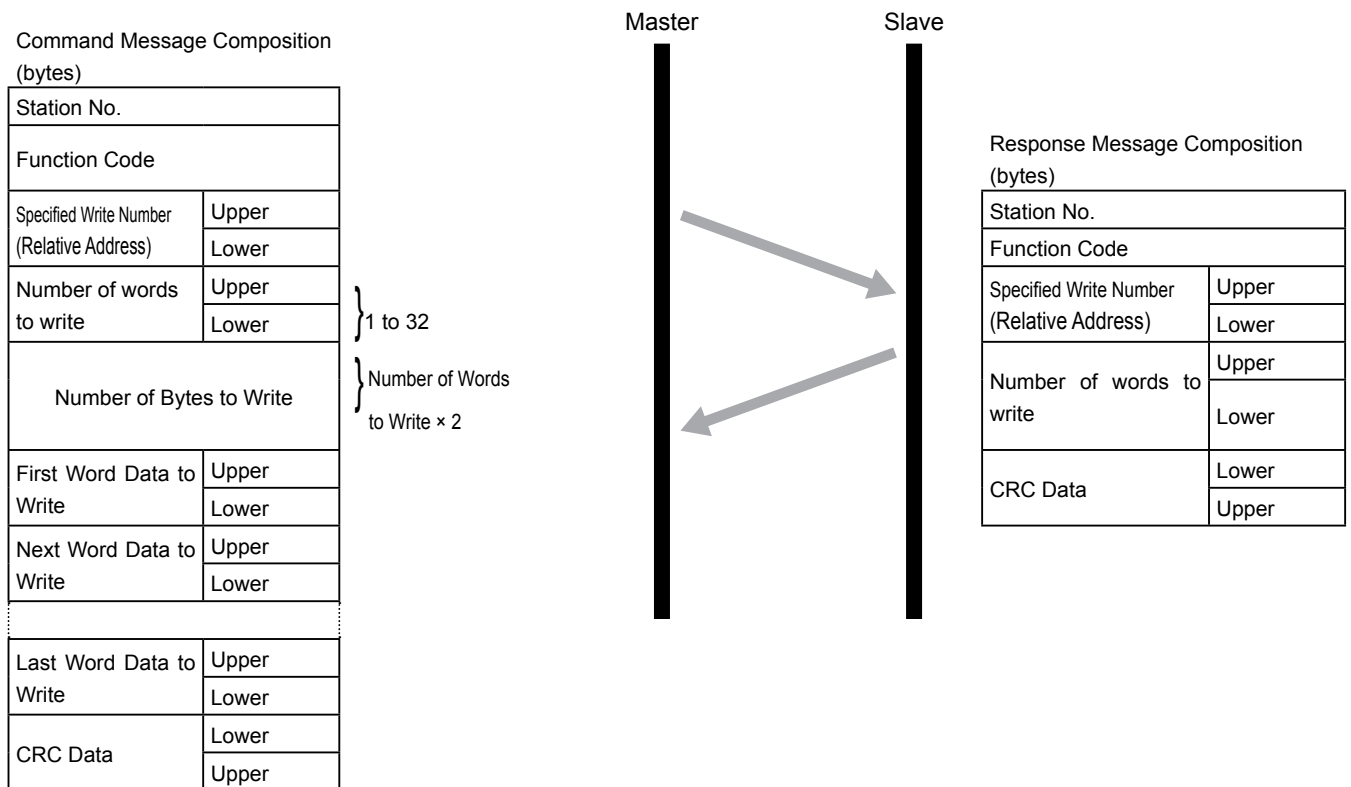

5.6 Command and Transmission Frame Details

• Example of Transmitting a Message

The message composition is as indicated below in case of write of the following PID (Proportional band, Integration time, Derivation time) parameters to Ch1 of station number 1.

P = 100.0 (= 1000D = 03E8H)

I = 10 (= 100D = 0064 H)

D = 5.0 (= 50D = 0032H)

- **Relative address of parameter [proportional band [P]]: 044DH, Number of data: 03H**

Command Message Composition
(bytes)

Station No.		01H
Function Code		10H
Specified Write Number (Relative Address)	Upper	04H
	Lower	4DH
Number of words to write	Upper	00H
	Lower	03H
Number of Bytes to Write		06H
First Word Data to Write	Upper	03H
	Lower	E8H
Next Word Data to Write	Upper	00H
	Lower	64H
Last Word Data to Write	Upper	00H
	Lower	32H
CRC Data	Lower	C0H
	Upper	B0H

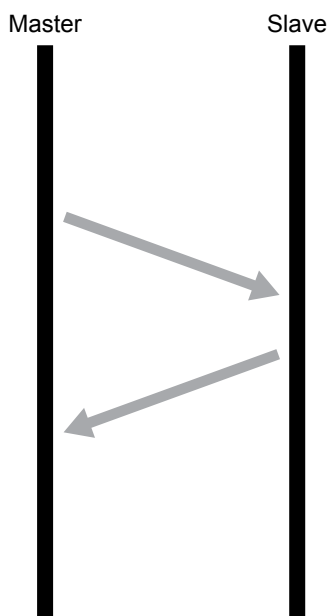

Response Message Composition
(bytes)

Station No.		01H
Function Code		10H
Specified Write Number (Relative Address)	Upper	04H
	Lower	4DH
Number of words to write	Upper	00H
	Lower	03H
CRC Data	Lower	11H
	Upper	2FH

Point

The decimal point cannot be included in transmission data, so data such as [100.0] is transmitted as [1000].

5.7 Address Map and Data Format

Register numbers of control module readout/write data set values are shown in a table.

Operation Parameters

Content	Readout/write data setting range	Depends on input range	Factory-set value	Register No. 1 (Ch1)	Register No. 2 (Ch2)	Register No. 3 (Ch3)	Register No. 4 (Ch4)
Local SV value	0 to 100%FS	○	0	40001 41001	40002 42001	40003 43001	40004 44001
Communication SV value	0 to 100%FS	○	0	40023 41100	40024 42100	40025 43100	40026 44100
MV value	-3.0 to 103.0%		—	40005 41002	40006 42002	40007 43002	40008 44002
Manual mode switch	0: Auto 1: Manual		0 (Auto)	40013 41003	40014 42003	40015 43003	40016 44003
RUN/Standby switch	0: RUN 1: Standby		0 (RUN)	40017 41004	40018 42004	40019 43004	40020 44004
Remote mode switch	0: Local 1: Remote		0 (Local)	40009 41007	40010 42007	40011 43007	40012 44007
Auto-tuning RUN command	0: Stop/End 1: Normal type 2: Low PV type		0 (Stop/End)	41005	42005	43005	44005
Digital output latch release command	0: OFF 1: Release latch		0 (OFF)	41031	42031	43031	44031
ALM1 set value 1	-100 to 100%FS	○	2.5%FS	41033	42033	43033	44033
ALM1 set value 2	-100 to 100%FS	○	2.5%FS	41034	42034	43034	44034
ALM2 set value 1	-100 to 100%FS	○	2.5%FS	41041	42041	43041	44041
ALM2 set value 2	-100 to 100%FS	○	2.5%FS	41042	42042	43042	44042
ALM3 set value 1	-100 to 100%FS	○	2.5%FS	41049	42049	43049	44049
ALM3 set value 2	-100 to 100%FS	○	2.5%FS	41050	42050	43050	44050
ALM4 set value 1	-100 to 100%FS	○	2.5%FS	41057	42057	43057	44057
ALM4 set value 2	-100 to 100%FS	○	2.5%FS	41058	42058	43058	44058
ALM5 set value 1	-100 to 100%FS	○	2.5%FS	41065	42065	43065	44065
ALM5 set value 2	-100 to 100%FS	○	2.5%FS	41066	42066	43066	44066

Control (PID) Parameters

Content	Readout/write data setting range	Depends on input range	Factory-set value	Register No. 1 (Ch1)	Register No. 2 (Ch2)	Register No. 3 (Ch3)	Register No. 4 (Ch4)
Proportional band [P]	0.0 to 999.9%		5.0	41102	42102	43102	44102
Integration time [I]	0 to 3200sec		240	41103	42103	43103	44103
Derivation time [D]	0.0 to 999.9sec		60.0	41104	42104	43104	44104
ON/OFF control hysteresis	0 to 50%FS	○	0.25%FS	41105	42105	43105	44105
Cooling proportional band coefficient [cool]	0.0 to 100.0		1.0	41106	42106	43106	44106
Dead band	-50.0 to 50.0%		0	41107	42107	43107	44107
Output convergence value	-100.0 to 100.0%		0	41108	42108	43108	44108
Anti-reset windup [ARW]	0 to 100%FS	○	100%FS	41109	42109	43109	44109
Direct/Reverse action setting [MV1/MV2]	0 : Reverse/None 1 : Direct/None 2 : Reverse/Direct 3 : Direct/Reverse 4 : Reverse/Reverse 5 : Direct/Direct		0 (Reverse/None)	41110	42110	43110	44110
SV Lower Limits	0 to 100%FS	○	0%FS	41218	42218	43218	44218
SV Upper Limits	0 to 100%FS	○	100%FS	41219	42219	43219	44219
MV1 Lower limits	-3.0 to 103.0%		-3.0	41255	42255	43255	44255
MV1 Upper limits	-3.0 to 103.0%		103.0	41256	42256	43256	44256
MV2 Lower limits	-3.0 to 103.0%		-3.0	41257	42257	43257	44257
MV2 Upper limits	-3.0 to 103.0%		103.0	41258	42258	43258	44258
Output limiter type setting	0: MV1 -3.0%/103.0% MV2 -3.0%/103.0% 1: MV1 Limit/103.0% MV2 -3.0%/103.0% 2: MV1 -3.0%/Limit MV2 -3.0%/103.0% 3: MV1 Limit/ Limit MV2 -3.0%/103.0% 4: MV1 -3.0%/103.0% MV2 Limit/103.0% 5: MV1 Limit/103.0% MV2 Limit/103.0% 6: MV1 -3.0%/Limit MV2 Limit/103.0% 7: MV1 Limit/Limit MV2 Limit/103.0% 8: MV1 -3.0%/103.0% MV2 -3.0%/Limit 9: MV1 Limit/103.0% MV2 -3.0%/Limit 10: MV1 -3.0%/Limit MV2 -3.0%/Limit 11: MV1 Limit/Limit MV2 -3.0%/Limit 12: MV1 -3.0%/103.0% MV2 Limit/Limit 13: MV1 Limit/103.0% MV2 Limit/Limit 14: MV1 -3.0%/Limit MV2 Limit/Limit 15: MV1 Limit/Limit MV2 Limit/Limit		0	41259	42259	43259	44259

Setup Parameters

Content	Readout/write data setting range	Depends on input range	Factory-set value	Register No. 1 (Ch1)	Register No. 2 (Ch2)	Register No. 3 (Ch3)	Register No. 4 (Ch4)
PV input type	0: Not selectable 1: Not selectable 2: Pt100 (0 to 150 °C) 3: Pt100 (-150 to 300 °C) 4: Pt100 (-150 to 850 °C) 5: J (0 to 400 °C) 6: J (0 to 800 °C) 7: K (0 to 400 °C) 8: K (0 to 800 °C) 9: K (0 to 1200 °C) 10: R (0 to 1600 °C) 11: B (0 to 1800 °C) 12: S (0 to 1600 °C) 13: T (-199 to 400 °C) 14: E (-199 to 800 °C) 18: N (0 to 1300 °C) 19: PL-2 (0 to 1300 °C) 21: Voltage (0 to 5V) 22: Voltage (1 to 5V) 23: Voltage (0 to 10V) 24: Voltage (2 to 10V)		7 (TC/Pt) 22 (VI)	40151 41029	40152 42029	40153 43029	40154 44029
PV input scale lower	-1999 to 9999		0%FS	41212	42212	43212	44212
PV input scale upper	-1999 to 9999		100%FS	41213	42213	43213	44213
Decimal place	0: No decimal point 1: One decimal place 2: Two decimal places		0 (TC/Pt) 1 (VI)	41214	42214	43214	44214
Temperature unit	0: Degree C 1: Degree F		0 (degree C)	41215	42215	43215	44215
PV input shift	-10 to 10%FS	○	0	41216	42216	43216	44216
SV value shift	-50 to 50%FS	○	0	41217	42217	43217	44217
PV input filter	0.0 to 120.0sec		2.0	41220	42220	43220	44220
PV display zero adjustment	-50 to 50%FS	○	0	41221	42221	43221	44221
PV display span adjustment	-50 to 50%FS	○	0	41222	42222	43222	44222
Cold junction compensation	0: OFF 1: ON		1 (ON)	41223	42223	43223	44223
RSV zero adjustment	-50 to 50%FS	○	0	41225	42225	43225	44225
RSV span adjustment	-50 to 50%FS	○	0	41226	42226	43226	44226
RSV input master Station No.	0 to 255		0	41532	42532	43532	44532
RSV input master Ch. No.	0 / 1 to 4		Each Ch.	41533	42533	43533	44533
FAULT MV1 set value	-3.0 to 103.0%		-3.0	41260	42260	43260	44260
FAULT MV2 set value	-3.0 to 103.0%		-3.0	41261	42261	43261	44261
Soft start MV1 value	-3.0 to 103.0%		103.0	41262	42262	43262	44262
Soft start MV2 value	-3.0 to 103.0%		103.0	41263	42263	43263	44263
Soft start time	0 to 99hr.59min.		0	41264	42264	43264	44264
Standby MV1 value	-3.0 to 103.0%		-3.0	41268	42268	43268	44268
Standby MV2 value	-3.0 to 103.0%		-3.0	41269	42269	43269	44269
Standby mode setting	0: ALM=OFF 1: ALM=ON		0 (ALM=OFF)	41270	42270	43270	44270
Linkage operation master Station No.	0 to 255		0	41536	42536	43536	44536
Linkage operation master Ch. No.	1 to 4		Each Ch.	41537	42537	43537	44537

System Parameters

Content	Readout/write data setting range	Depends on input range	Factory-set value	Register No. 1 (Ch1)	Register No. 2 (Ch2)	Register No. 3 (Ch3)	Register No. 4 (Ch4)
Current output range	4: 0 to 20mA 5: 4 to 20mA		5 (4-20mA)	40166 41801	40167 42801	40168 43801	40169 44801
Output type	0: PV of own station 1: SV of own station 2: DV of own station 3: MV1 of own station 4: MV2 of own station 5: PV of other stations 6: SV of other stations 7: MV of other stations		3 (MV1 of own station)	40171 41803	40177 42803	40183 43803	40189 44803
Proportional cycle	1 to 120 sec		2 (SSR drive)/30 (relay)	40176	40182	40188	40194
Output master Station No.	0 to 255 stations		0	40172 41804	40178 42804	40184 43804	40190 44804
Output master Ch. No.	1 to 4Ch		Each Ch.	40173 41805	40179 42805	40185 43805	40191 44805
Output scaling base	-100.0 to 100.0%		0.0	40175 41807	40181 42807	40187 43807	40193 44807
Output scaling span	-100.0 to 100.0%		100.0	40174 41806	40180 42806	40186 43806	40192 44806
Output shutdown	0000 to 1111 bit0 : Output 1 shutdown bit1 : Output 2 shutdown bit2 : Output 3 shutdown bit3 : Output 4 shutdown		0000	40201			

Content	Readout/write data setting range	Depends on input range	Factory-set value	Register No. 1 (Ch1)	Register No. 2 (Ch2)	Register No. 3 (Ch3)	Register No. 4 (Ch4)
DI-1 function select	0: No function 1: Run/Standby switch 2: Auto/Manual switch 3: Local/Remote switch 4: No function 5: No function 6: Start AT (Normal type) 7: Start AT (Low PV type) 8: No function 9: No function 10: Ramp SV ON/OFF 11: Ramp SV HOLD 12: No function 13: No function 14: No function 15: No function 16: No function 17: Latch release (all) 18: Latch release (DO1) 19: Latch release (DO2) 20: Latch release (DO3) 21: Latch release (DO4) 22: Latch release (DO5) 23: No function 24: No function 25: No function 26: Start timer (DO1) 27: Start timer (DO2) 28: Start timer (DO3) 29: Start timer (DO4) 30: Start timer (DO5) 31: No function 32: No function 33: No function 34: No function 35: No function 36: No function 37: No function 38: No function 39: No function 40: No function 41: No function 42: No function 43: No function 44: No function 45: No function 46: No function 47: No function 48: No function 49: Output 1 shutdown 50: Output 2 shutdown 51: Output 3 shutdown 52: Output 4 shutdown		0 (No function)	41013	42013	43013	44013

5.7 Address Map and Data Format

Content	Readout/write data setting range	Depends on input range	Factory-set value	Register No. 1 (Ch1)	Register No. 2 (Ch2)	Register No. 3 (Ch3)	Register No. 4 (Ch4)
DI-2 function select	0 to 52		0	41014	42014	43014	44014
DI-3 function select	0 to 52		0	41015	42015	43015	44015
DI-4 function select	0 to 52		0	41016	42016	43016	44016
DI-5 function select	0 to 52		0	41017	42017	43017	44017
DI-6 function select	0 to 52		0	41018	42018	43018	44018
DI-7 function select	0 to 52		0	41019	42019	43019	44019
DI-8 function select	0 to 52		0	41020	42020	43020	44020
DI-9 function select	0 to 52		0	41021	42021	43021	44021
DI-10 function select	0 to 52		0	41022	42022	43022	44022
DI-11 function select	0 to 52		0	41023	42023	43023	44023
DI-12 function select	0 to 52		0	41024	42024	43024	44024
DI-13 function select	0 to 52		0	41025	42025	43025	44025
DI-14 function select	0 to 52		0	41026	42026	43026	44026
DI-15 function select	0 to 52		0	41027	42027	43027	44027
DI-16 function select	0 to 52		0	41028	42028	43028	44028
DI master Station No. setting	0 to 255		0	41011	42011	43011	44011
DO1 output event type setting	0 to 102		0	41032	42032	43032	44032
DO1 option function setting	0 to 15 (bit data : 0000 to 1111) bit 0: Alarm latch function bit 1: Error input alarm function bit 2: Non-excitation output function bit 3: Hold reset function		0000	41036	42036	43036	44036
DO2 output event type setting	0 to 102		0	41040	42040	43040	44040
DO2 option function setting	0 to 15 (bit data : 0000 to 1111) bit 0: Alarm latch function bit 1: Error input alarm function bit 2: Non-excitation output function bit 3: Hold reset function		0000	41044	42044	43044	44044
DO3 output event type setting	0 to 102		0	41048	42048	43048	44048
DO3 option function setting	0 to 15 (bit data : 0000 to 1111) bit 0: Alarm latch function bit 1: Error input alarm function bit 2: Non-excitation output function bit 3: Hold reset function		0000	41052	42052	43052	44052
DO4 output event type setting	0 to 102		0	41056	42056	43056	44056
DO4 option function setting	0 to 15 (bit data : 0000 to 1111) bit 0: Alarm latch function bit 1: Error input alarm function bit 2: Non-excitation output function bit 3: Hold reset function		0000	41060	42060	43060	44060
DO5 output event type setting	0 to 102		0	41064	42064	43064	44064
DO5 option function setting	0 to 15 (bit data : 0000 to 1111) bit 0: Alarm latch function bit 1: Error input alarm function bit 2: Non-excitation output function bit 3: Hold reset function		0000	41068	42068	43068	44068

Content	Readout/write data setting range	Depends on input range	Factory-set value	Register No. 1 (Ch1)	Register No. 2 (Ch2)	Register No. 3 (Ch3)	Register No. 4 (Ch4)
Ramp SV ON/OFF	0: OFF 1: ON		1 (ON)	41299	42299	43299	44299
Ramp SV - decline	0 to 100%FS	○	0	41300	42300	43300	44300
Ramp SV - incline	0 to 100%FS	○	0	41301	42301	43301	44301
Ramp SV slope time units	0: Slope deg/hr. 1: Slope deg/min.		0 (Slope deg/hr.)	41302	42302	43302	44302
Control algorithm	0: PID 1: FUZZY PID 2: PID against open-loop		0 (PID)	41291	42291	43291	44291
ON/OFF hysteresis setting	0: OFF 1: ON		1 (ON)	41292	42292	43292	44292
Mode at startup	0: Auto mode 1: Manual mode 2: Remote mode 3: Standby mode		0 (Auto mode)	41304	42304	43304	44304

Alarm Parameter

Content	Readout/write data setting range	Depends on input range	Factory-set value	Register No. 1 (Ch1)	Register No. 2 (Ch2)	Register No. 3 (Ch3)	Register No. 4 (Ch4)
ALM1 hysteresis	0 to 50%FS	○	0.25%FS	41035	42035	43035	44035
ALM1 delay time	0 to 99min.59sec. /0 to 99hr.59min.		0	41037	42037	43037	44037
ALM1 delay time units	0: sec. 1: min.		0 (Second)	41038	42038	43038	44038
ALM2 hysteresis	0 to 50%FS	○	0.25%FS	41043	42043	43043	44043
ALM2 delay time	0 to 99min.59sec. /0 to 99hr.59min.		0	41045	42045	43045	44045
ALM2 delay time units	0: sec. 1: min.		0 (Second)	41046	42046	43046	44046
ALM3 hysteresis	0 to 50%FS	○	0.25%FS	41051	42051	43051	44051
ALM3 delay time	0 to 99min.59sec. /0 to 99hr.59min.		0	41053	42053	43053	44053
ALM3 delay time units	0: sec. 1: min.		0 (Second)	41054	42054	43054	44054
ALM4 hysteresis	0 to 50%FS	○	0.25%FS	41059	42059	43059	44059
ALM4 delay time	0 to 99min.59sec. /0 to 99hr.59min.		0	41061	42061	43061	44061
ALM4 delay time units	0: sec. 1: min.		0 (Second)	41062	42062	43062	44062
ALM5 hysteresis	0 to 50%FS	○	0.25%FS	41067	42067	43067	44067
ALM5 delay time	0 to 99min.59sec. /0 to 99hr.59min.		0	41069	42069	43069	44069
ALM5 delay time units	0: sec. 1: min.		0 (Second)	41070	42070	43070	44070
Object Ch. No. for interchannel ALM1	1 to 4		1	41039	42039	43039	44039
Object Ch. No. for interchannel ALM2	1 to 4		1	41047	42047	43047	44047
Object Ch. No. for interchannel ALM3	1 to 4		1	41055	42055	43055	44055
Object Ch. No. for interchannel ALM4	1 to 4		1	41063	42063	43063	44063
Object Ch. No. for interchannel ALM5	1 to 4		1	41071	42071	43071	44071
CT[A] HB alarm set value	0.0 to 50.0(A)		0	41072	42072	43072	44072
CT[A]HB alarm hysteresis	0.0 to 50.0(A)		0.5	41073	42073	43073	44073
CT[A] load short-circuit alarm set value	0.0 to 50.0(A)		0	41074	42074	43074	44074
CT[A] load short-circuit alarm hysteresis	0.0 to 50.0(A)		0.5	41075	42075	43075	44075
CT[B] HB alarm set value	0.0 to 50.0(A)		0	41076	42076	43076	44076
CT[B]HB alarm hysteresis	0.0 to 50.0(A)		0.5	41077	42077	43077	44077
CT[B] load short-circuit alarm set value	0.0 to 50.0(A)		0	41078	42078	43078	44078
CT[B] load short-circuit alarm hysteresis	0.0 to 50.0(A)		0.5	41079	42079	43079	44079
Loop break detection time	0 to 9999sec		0 (detection OFF)	41080	42080	43080	44080
Loop break detection band	0 to 100%FS	○	2.5%FS	41081	42081	43081	44081

Communication Parameters

Content	Readout/write data setting range	Depends on input range	Factory-set value	Register No. 1 (Ch1)	Register No. 2 (Ch2)	Register No. 3 (Ch3)	Register No. 4 (Ch4)
RS-485 Parity setting	0: NONE 1: ODD 2: EVEN		0		40111		
RS-485 Communication speed	0: 9.6kbps 1: 19.2kbps 2: 38.4kbps 3: Forbidden 4: 115.2kbps		1		40115		
RS-485 Communication permission	0: Read only 1: Read/Write		1 (R/W)		40114		
RS-485 Response interval time	0 to 25 (20ms/1digit)		0		40113		
Enhanced communication module (PUMC) connection	0: PUMC not connected (RS485 Enable) 1: PUMC connected (RS485 Disable)		0 (RS-485 valid)		40116		
Master/slave setting in connected modules	0: Master 1: Slave		1 (Slave)		40117		
User address 01	30000 to 49999		30002(PV1)		40301		
User address 02	30000 to 49999		30002(PV1)		40302		
User address 03	30000 to 49999		30002(PV1)		40303		
User address 04	30000 to 49999		30002(PV1)		40304		
User address 05	30000 to 49999		30002(PV1)		40305		
User address 06	30000 to 49999		30002(PV1)		40306		
User address 07	30000 to 49999		30002(PV1)		40307		
User address 08	30000 to 49999		30002(PV1)		40308		
User address 09	30000 to 49999		30002(PV1)		40309		
User address 10	30000 to 49999		30002(PV1)		40310		
User address 11	30000 to 49999		30002(PV1)		40311		
User address 12	30000 to 49999		30002(PV1)		40312		
User address 13	30000 to 49999		30002(PV1)		40313		
User address 14	30000 to 49999		30002(PV1)		40314		
User address 15	30000 to 49999		30002(PV1)		40315		
User address 16	30000 to 49999		30002(PV1)		40316		
User address 17	30000 to 49999		30002(PV1)		40317		
User address 18	30000 to 49999		30002(PV1)		40318		
User address 19	30000 to 49999		30002(PV1)		40319		
User address 20	30000 to 49999		30002(PV1)		40320		
User address 21	30000 to 49999		30002(PV1)		40321		
User address 22	30000 to 49999		30002(PV1)		40322		
User address 23	30000 to 49999		30002(PV1)		40323		
User address 24	30000 to 49999		30002(PV1)		40324		
User address 25	30000 to 49999		30002(PV1)		40325		
User address 26	30000 to 49999		30002(PV1)		40326		
User address 27	30000 to 49999		30002(PV1)		40327		
User address 28	30000 to 49999		30002(PV1)		40328		
User address 29	30000 to 49999		30002(PV1)		40329		
User address 30	30000 to 49999		30002(PV1)		40330		
User address 31	30000 to 49999		30002(PV1)		40331		
User address 32	30000 to 49999		30002(PV1)		40332		

5.7 Address Map and Data Format

Content	Readout/write data setting range	Depends on input range	Factory-set value	Register No. 1 (Ch1)	Register No. 2 (Ch2)	Register No. 3 (Ch3)	Register No. 4 (Ch4)
User data 01	Depends on "User address 01"		—	45001			
User data 02	Depends on "User address 02"		—	45002			
User data 03	Depends on "User address 03"		—	45003			
User data 04	Depends on "User address 04"		—	45004			
User data 05	Depends on "User address 05"		—	45005			
User data 06	Depends on "User address 06"		—	45006			
User data 07	Depends on "User address 07"		—	45007			
User data 08	Depends on "User address 08"		—	45008			
User data 09	Depends on "User address 09"		—	45009			
User data 10	Depends on "User address 10"		—	45010			
User data 11	Depends on "User address 11"		—	45011			
User data 12	Depends on "User address 12"		—	45012			
User data 13	Depends on "User address 13"		—	45013			
User data 14	Depends on "User address 14"		—	45014			
User data 15	Depends on "User address 15"		—	45015			
User data 16	Depends on "User address 16"		—	45016			
User data 17	Depends on "User address 17"		—	45017			
User data 18	Depends on "User address 18"		—	45018			
User data 19	Depends on "User address 19"		—	45019			
User data 20	Depends on "User address 20"		—	45020			
User data 21	Depends on "User address 21"		—	45021			
User data 22	Depends on "User address 22"		—	45022			
User data 23	Depends on "User address 23"		—	45023			
User data 24	Depends on "User address 24"		—	45024			
User data 25	Depends on "User address 25"		—	45025			
User data 26	Depends on "User address 26"		—	45026			
User data 27	Depends on "User address 27"		—	45027			

Content	Readout/write data setting range	Depends on input range	Factory-set value	Register No. 1 (Ch1)	Register No. 2 (Ch2)	Register No. 3 (Ch3)	Register No. 4 (Ch4)
User data 28	Depends on "User address 28"		—			45028	
User data 29	Depends on "User address 29"		—			45029	
User data 30	Depends on "User address 30"		—			45030	
User data 31	Depends on "User address 31"		—			45031	
User data 32	Depends on "User address 32"		—			45032	

Configuration Parameters

Content	Readout/write data setting range	Depends on input range	Factory-set value	Register No. 1 (Ch1)	Register No. 2 (Ch2)	Register No. 3 (Ch3)	Register No. 4 (Ch4)
Control when input burn-out is detected	0: Stop control 1: Continue control		0 (Stop control)	41407	42407	43407	44407
LED2 Lamp Allocation	0 to 255		1	40222			
LED3 Lamp Allocation	0 to 255		12	40223			
LED4 Lamp Allocation	0 to 255		13	40224			
LED5 Lamp Allocation	0 to 255		14	40225			
LED6 Lamp Allocation	0 to 255		15	40226			
Reset main unit	0: Do nothing 1: Reset main unit		0	40101			

Monitor Parameters

Content	Readout/write data setting range	Depends on input range	Factory-set value	Register No. 1 (Ch1)	Register No. 2 (Ch2)	Register No. 3 (Ch3)	Register No. 4 (Ch4)
SV value	0 to 100%FS	○	—	30905	30906	30907	30908
Remote mode switch	0: Local 1: Remote		—	30030 31037	30031 32037	30032 33037	30033 34037
System time	0 to 65535		—	30001			
Measurement value (PV)	-5 to 105%FS		—	30002 31001	30003 32001	30004 33001	30005 34001
Set value (SV)	0 to 100%FS		—	30006 31002	30007 32002	30008 33002	30009 34002
DV	-105 to 105%FS		—	30010 31003	30011 32003	30012 33003	30013 34003
Output value (MV1)	-3.0 to 103.0%		—	30014 31004	30016 32004	30018 33004	30020 34004
Output value (MV2)	-3.0 to 103.0%		—	30015 31005	30017 32005	30019 33005	30021 34005
Remote SV (RSV)	0.0 to 100.0%FS		—	30022 31045	30023 32045	30024 33045	30025 34045
RCJ temp	-3276.7 to 3276.7 °C		—	30110 31016	30111 32016	30112 33016	30113 34016
Heater current [A]	0.0 to 50.0A		—	30071 31046	30073 32046	30075 33046	30077 34046
Heater current [B]	0.0 to 50.0A		—	30072 31047	30074 32047	30076 33047	30078 34047
Leak current [A]	0.0 to 50.0A		—	30081 31048	30083 32048	30085 33048	30087 34048
Leak current [B]	0.0 to 50.0A		—	30082 31049	30084 32049	30086 33049	30088 34049
Error source display	0000 to FFFF		—	31008	32008	33008	34008
Alarm 1-5 status	0000 to 001F		—	31007	32007	33007	34007
Event input status	0000 to FFFF		—	31061	32061	33061	34061
Remaining time on timer 1	0 to 99min.59sec. /0 to 99hr.59min.		—	31011	32011	33011	34011
Remaining time on timer 2	0 to 99min.59sec. /0 to 99hr.59min.		—	31012	32012	33012	34012

Content	Readout/write data setting range	Depends on input range	Factory-set value	Register No. 1 (Ch1)	Register No. 2 (Ch2)	Register No. 3 (Ch3)	Register No. 4 (Ch4)
Remaining time on timer 3	0 to 99min.59sec. /0 to 99hr.59min.		—	31013	32013	33013	34013
Remaining time on timer 4	0 to 99min.59sec. /0 to 99hr.59min.		—	31014	32014	33014	34014
Remaining time on timer 5	0 to 99min.59sec. /0 to 99hr.59min.		—	31015	32015	33015	34015
Output value	-3.0 to 103.0%		—	30120	30121	30122	30123
RS-485 Communication permission	0: Read only 1: Read/Write		—	30062			

Order of Register Numbers

Content	Register number	Relative address
Ch1 Local SV value	40001	0000h
Ch2 Local SV value	40002	0001h
Ch3 Local SV value	40003	0002h
Ch4 Local SV value	40004	0003h
Ch1 MV value	40005	0004h
Ch2 MV value	40006	0005h
Ch3 MV value	40007	0006h
Ch4 MV value	40008	0007h
Ch1 Remote mode switch	40009	0008h
Ch2 Remote mode switch	40010	0009h
Ch3 Remote mode switch	40011	000Ah
Ch4 Remote mode switch	40012	000Bh
Ch1 Manual mode switch	40013	000Ch
Ch2 Manual mode switch	40014	000Dh
Ch3 Manual mode switch	40015	000Eh
Ch4 Manual mode switch	40016	000Fh
Ch1 RUN/Standby switch	40017	0010h
Ch2 RUN/Standby switch	40018	0011h
Ch3 RUN/Standby switch	40019	0012h
Ch4 RUN/Standby switch	40020	0013h
Ch1 Communication SV value	40023	0016h
Ch2 Communication SV value	40024	0017h
Ch3 Communication SV value	40025	0018h
Ch4 Communication SV value	40026	0019h
Reset main unit	40101	0064h
RS-485 Parity setting	40111	006Eh
RS-485 Response interval time	40113	0070h
RS-485 Communication permission	40114	0071h
RS-485 Communication speed	40115	0072h
Enhanced communication module (PUMC) connection	40116	0073h
Master/slave setting in connected modules	40117	0074h
Ch1 PV input type	40151	0096h
Ch2 PV input type	40152	0097h
Ch3 PV input type	40153	0098h
Ch4 PV input type	40154	0099h
OUT1 Current output range	40166	00A5h
OUT2 Current output range	40167	00A6h
OUT3 Current output range	40168	00A7h
OUT4 Current output range	40169	00A8h
OUT1 Output type	40171	00AAh
OUT1 Output master St. No.	40172	00ABh
OUT1 Output master Ch. No.	40173	00ACh
OUT1 Output scaling span	40174	00ADh
OUT1 Output scaling base	40175	00AEh
OUT1 Proportion cycle	40176	00AFh
OUT2 Output type	40177	00B0h
OUT2 Output master St. No.	40178	00B1h
OUT2 Output master Ch. No.	40179	00B2h
OUT2 Output scaling span	40180	00B3h
OUT2 Output scaling base	40181	00B4h

Content	Register number	Relative address
OUT2 Proportion cycle	40182	00B5h
OUT3 Output type	40183	00B6h
OUT3 Output master St. No.	40184	00B7h
OUT3 Output master Ch. No.	40185	00B8h
OUT3 Output scaling span	40186	00B9h
OUT3 Output scaling base	40187	00BAh
OUT3 Proportion cycle	40188	00BBh
OUT4 Output type	40189	00BCh
OUT4 Output master St. No.	40190	00BDh
OUT4 Output master Ch. No.	40191	00BEh
OUT4 Output scaling span	40192	00BFh
OUT4 Output scaling base	40193	00C0h
OUT4 Proportion cycle	40194	00C1h
Output shutdown	40201	00C8h
LED2 Lamp Allocation	40222	00DDh
LED3 Lamp Allocation	40223	00DEh
LED4 Lamp Allocation	40224	00DFh
LED5 Lamp Allocation	40225	00E0h
LED6 Lamp Allocation	40226	00E1h
User address 01	40301	012Ch
User address 02	40302	012Dh
User address 03	40303	012Eh
User address 04	40304	012Fh
User address 05	40305	0130h
User address 06	40306	0131h
User address 07	40307	0132h
User address 08	40308	0133h
User address 09	40309	0134h
User address 10	40310	0135h
User address 11	40311	0136h
User address 12	40312	0137h
User address 13	40313	0138h
User address 14	40314	0139h
User address 15	40315	013Ah
User address 16	40316	013Bh
User address 17	40317	013Ch
User address 18	40318	013Dh
User address 19	40319	013Eh
User address 20	40320	013Fh
User address 21	40321	0140h
User address 22	40322	0141h
User address 23	40323	0142h
User address 24	40324	0143h
User address 25	40325	0144h
User address 26	40326	0145h
User address 27	40327	0146h
User address 28	40328	0147h
User address 29	40329	0148h
User address 30	40330	0149h
User address 31	40331	014Ah
User address 32	40332	014Bh
Ch1 Local SV value	41001	03E8h
Ch1 MV value	41002	03E9h

Content	Register number	Relative address
Ch1 Manual mode switch	41003	03EAh
Ch1 RUN/Standby switch	41004	03EBh
Ch1 Auto-tuning RUN command	41005	03ECh
Ch1 Remote mode switch	41007	03EEh
Ch1 DI master Station No. setting	41011	03F2h
Ch1 DI-1 function select	41013	03F4h
Ch1 DI-2 function select	41014	03F5h
Ch1 DI-3 function select	41015	03F6h
Ch1 DI-4 function select	41016	03F7h
Ch1 DI-5 function select	41017	03F8h
Ch1 DI-6 function select	41018	03F9h
Ch1 DI-7 function select	41019	03FAh
Ch1 DI-8 function select	41020	03FBh
Ch1 DI-9 function select	41021	03FCh
Ch1 DI-10 function select	41022	03FDh
Ch1 DI-11 function select	41023	03FEh
Ch1 DI-12 function select	41024	03FFh
Ch1 DI-13 function select	41025	0400h
Ch1 DI-14 function select	41026	0401h
Ch1 DI-15 function select	41027	0402h
Ch1 DI-16 function select	41028	0403h
OUT1 PV input type	41029	0404h
Ch1 Digital output latch release command	41031	0406h
Ch1 DO1 output event type setting	41032	0407h
Ch1 ALM1 set value 1	41033	0408h
Ch1 ALM1 set value 2	41034	0409h
Ch1 ALM1 hysteresis	41035	040Ah
Ch1 DO1 option function setting	41036	040Bh
Ch1 ALM1 delay time	41037	040Ch
Ch1 ALM1 delay time units	41038	040Dh
Ch1 Object Ch. No. for interchannel ALM1	41039	040Eh
Ch1 DO2 option event type setting	41040	040Fh
Ch1 ALM2 set value 1	41041	0410h
Ch1 ALM2 set value 2	41042	0411h
Ch1 ALM2 hysteresis	41043	0412h
Ch1 DO2 option function setting	41044	0413h
Ch1 ALM2 delay time	41045	0414h
Ch1 ALM2 delay time units	41046	0415h
Ch1 Object Ch. No. for interchannel ALM2	41047	0416h
Ch1 DO3 option event type setting	41048	0417h
Ch1 ALM3 set value 1	41049	0418h
Ch1 ALM3 set value 2	41050	0419h
Ch1 ALM3 hysteresis	41051	041Ah
Ch1 DO3 option function setting	41052	041Bh
Ch1 ALM3 delay time	41053	041Ch
Ch1 ALM3 delay time units	41054	041Dh
Ch1 Object Ch. No. for interchannel ALM3	41055	041Eh

Content	Register number	Relative address
Ch1 DO4 option event type setting	41056	041Fh
Ch1 ALM4 set value 1	41057	0420h
Ch1 ALM4 set value 2	41058	0421h
Ch1 ALM4 hysteresis	41059	0422h
Ch1 DO4 option function setting	41060	0423h
Ch1 ALM4 delay time	41061	0424h
Ch1 ALM4 delay time units	41062	0425h
Ch1 Object Ch. No. for interchannel ALM4	41063	0426h
Ch1 DO5 option event type setting	41064	0427h
Ch1 ALM5 set value 1	41065	0428h
Ch1 ALM5 set value 2	41066	0429h
Ch1 ALM5 hysteresis	41067	042Ah
Ch1 DO5 option function setting	41068	042Bh
Ch1 ALM5 delay time	41069	042Ch
Ch1 ALM5 delay time units	41070	042Dh
Ch1 Object Ch. No. for interchannel ALM5	41071	042Eh
Ch1 CT[A] HB alarm set value	41072	042Fh
Ch1 CT[A] HB alarm hysteresis	41073	0430h
Ch1 CT[A] load short-circuit alarm set value	41074	0431h
Ch1 CT[A] load short-circuit alarm hysteresis	41075	0432h
Ch1 CT[B] HB alarm set value	41076	0433h
Ch1 CT[B] HB alarm hysteresis	41077	0434h
Ch1 CT[B] load short-circuit alarm set value	41078	0435h
Ch1 CT[B] load short-circuit alarm hysteresis	41079	0436h
Ch1 Loop break detection time	41080	0437h
Ch1 Loop break detection band	41081	0438h
Ch1 Communication SV value	41100	044Bh
Ch1 Local SV value	41101	044Ch
Ch1 Proportional band [P]	41102	044Dh
Ch1 Integration time [I]	41103	044Eh
Ch1 Derivation time [D]	41104	044Fh
Ch1 ON/OFF control hysteresis	41105	0450h
Ch1 Cooling proportional band coefficient [cool]	41106	0451h
Ch1 Dead band	41107	0452h
Ch1 Output convergence value	41108	0453h
Ch1 Anti-reset windup [ARW]	41109	0454h
Ch1 Direct/reverse action setting [MV1/MV2]	41110	0455h
Ch1 PV input scale lower	41212	04BBh
Ch1 PV input scale upper	41213	04BCh
Ch1 Decimal place	41214	04BDh
Ch1 Temperature unit	41215	04BEh
Ch1 PV input shift	41216	04BFh
Ch1 SV value shift	41217	04C0h
Ch1 SV lower limits	41218	04C1h
Ch1 SV upper limits	41219	04C2h

5.7 Address Map and Data Format

Content	Register number	Relative address
Ch1 PV input filter	41220	04C3h
Ch1 PV display zero adjustment	41221	04C4h
Ch1 PV display span adjustment	41222	04C5h
Ch1 Cold junction compensation	41223	04C6h
Ch1 Remote mode switch	41224	04C7h
Ch1 RSV zero adjustment	41225	04C8h
Ch1 RSV span adjustment	41226	04C9h
Ch1 MV1 lower limits	41255	04E6h
Ch1 MV1 upper limits	41256	04E7h
Ch1 MV2 lower limits	41257	04E8h
Ch1 MV2 upper limits	41258	04E9h
Ch1 Output limiter type setting	41259	04EAh
Ch1 FAULT MV1 set value	41260	04EBh
Ch1 FAULT MV2 set value	41261	04ECh
Ch1 Soft start MV1 value	41262	04EDh
Ch1 Soft start MV2 value	41263	04EEh
Ch1 Soft start time	41264	04EFh
Ch1 Standby MV1 value	41268	04F3h
Ch1 Standby MV2 value	41269	04F4h
Ch1 Standby mode setting	41270	04F5h
Ch1 Control algorithm	41291	050Ah
Ch1 ON/OFF hysteresis setting	41292	050Bh
Ch1 Ramp SV ON/OFF	41299	0512h
Ch1 Ramp SV - decline	41300	0513h
Ch1 Ramp SV - incline	41301	0514h
Ch1 Ramp SV slope time units	41302	0515h
Ch1 Mode at startup	41304	0517h
Ch1 Control when input burnout is detected	41407	057Eh
Ch1 RSV input master Station No.	41532	05FBh
Ch1 RSV input master Ch. No.	41533	05FCh
Ch1 Linkage operation master Station No.	41536	05FFh
Ch1 Linkage operation master Ch. No.	41537	0600h
Out1 Current output range	41801	0708h
Out1 Output type	41803	070Ah
Out1 Output master Station No.	41804	070Bh
Out1 Output master Ch. No.	41805	070Ch
Out1 Output scaling span	41806	070Dh
Out1 Output scaling base	41807	070Eh
Ch2 Local SV value	42001	07D0h
Ch2 MV value	42002	07D1h
Ch2 Manual mode switch	42003	07D2h
Ch2 RUN/Standby switch	42004	07D3h
Ch2 Auto-tuning RUN command	42005	07D4h
Ch2 Remote mode switch	42007	07D6h
Ch2 DI master Station No. setting	42011	07DAh
Ch2 DI-1 function select	42013	07DCh
Ch2 DI-2 function select	42014	07DDh
Ch2 DI-3 function select	42015	07DEh
Ch2 DI-4 function select	42016	07DFh
Ch2 DI-5 function select	42017	07E0h
Ch2 DI-6 function select	42018	07E1h

Content	Register number	Relative address
Ch2 DI-7 function select	42019	07E2h
Ch2 DI-8 function select	42020	07E3h
Ch2 DI-9 function select	42021	07E4h
Ch2 DI-10 function select	42022	07E5h
Ch2 DI-11 function select	42023	07E6h
Ch2 DI-12 function select	42024	07E7h
Ch2 DI-13 function select	42025	07E8h
Ch2 DI-14 function select	42026	07E9h
Ch2 DI-15 function select	42027	07EAh
Ch2 DI-16 function select	42028	07EBh
OUT2 PV input type	42029	07ECh
Ch2 Digital output latch release command	42031	07EEh
Ch2 DO1 output event type setting	42032	07EFh
Ch2 ALM1 set value 1	42033	07F0h
Ch2 ALM1 set value 2	42034	07F1h
Ch2 ALM1 hysteresis	42035	07F2h
Ch2 DO1 option function setting	42036	07F3h
Ch2 ALM1 delay time	42037	07F4h
Ch2 ALM1 delay time units	42038	07F5h
Ch2 Object Ch. No. for interchannel ALM1	42039	07F6h
Ch2 DO2 output event type setting	42040	07F7h
Ch2 ALM2 set value 1	42041	07F8h
Ch2 ALM2 set value 2	42042	07F9h
Ch2 ALM2 hysteresis	42043	07FAh
Ch2 DO2 option function setting	42044	07FBh
Ch2 ALM2 delay time	42045	07FCh
Ch2 ALM2 delay time units	42046	07FDh
Ch2 Object Ch. No. for interchannel ALM2	42047	07FEh
Ch2 DO3 output event type setting	42048	07FFh
Ch2 ALM3 set value 1	42049	0800h
Ch2 ALM3 set value 2	42050	0801h
Ch2 ALM3 hysteresis	42051	0802h
Ch2 DO3 option function setting	42052	0803h
Ch2 ALM3 delay time	42053	0804h
Ch2 ALM3 delay time units	42054	0805h
Ch2 Object Ch. No. for interchannel ALM3	42055	0806h
Ch2 DO4 output event type setting	42056	0807h
Ch2 ALM4 set value 1	42057	0808h
Ch2 ALM4 set value 2	42058	0809h
Ch2 ALM4 hysteresis	42059	080Ah
Ch2 DO4 option function setting	42060	080Bh
Ch2 ALM4 delay time	42061	080Ch
Ch2 ALM4 delay time units	42062	080Dh
Ch2 Object Ch. No. for interchannel ALM4	42063	080Eh
Ch2 DO5 output event type setting	42064	080Fh
Ch2 ALM5 set value 1	42065	0810h

Content	Register number	Relative address
Ch2 ALM5 set value 2	42066	0811h
Ch2 ALM5 hysteresis	42067	0812h
Ch2 DO5 option function setting	42068	0813h
Ch2 ALM5 delay time	42069	0814h
Ch2 ALM5 delay time units	42070	0815h
Ch2 Object Ch. No. for interchannel ALM5	42071	0816h
Ch2 CT[A] HB alarm set value	42072	0817h
Ch2 CT[A] HB alarm hysteresis	42073	0818h
Ch2 CT[A] load short-circuit alarm set value	42074	0819h
Ch2 CT[A] load short-circuit alarm hysteresis	42075	081Ah
Ch2 CT[B] HB alarm set value	42076	081Bh
Ch2 CT[B] HB alarm hysteresis	42077	081Ch
Ch2 CT[B] load short-circuit alarm set value	42078	081Dh
Ch2 CT[B] load short-circuit alarm hysteresis	42079	081Eh
Ch2 Loop break detection time	42080	081Fh
Ch2 Loop break detection band	42081	0820h
Ch2 Communication SV value	42100	0833h
Ch2 Local SV value	42101	0834h
Ch2 Proportional band [P]	42102	0835h
Ch2 Integration time [I]	42103	0836h
Ch2 Derivation time [D]	42104	0837h
Ch2 ON/OFF control hysteresis	42105	0838h
Ch2 Cooling proportional band coefficient [cool]	42106	0839h
Ch2 Dead band	42107	083Ah
Ch2 Output convergence value	42108	083Bh
Ch2 Anti-reset windup [ARW]	42109	083Ch
Ch2 Direct/reverse action setting [MV1/MV2]	42110	083Dh
Ch2 PV input scale lower	42212	08A3h
Ch2 PV input scale upper	42213	08A4h
Ch2 Decimal place	42214	08A5h
Ch2 Temperature unit	42215	08A6h
Ch2 PV input shift	42216	08A7h
Ch2 SV value shift	42217	08A8h
Ch2 SV lower limits	42218	08A9h
Ch2 SV upper limits	42219	08AAh
Ch2 PV input filter	42220	08ABh
Ch2 PV display zero adjustment	42221	08ACh
Ch2 PV display span adjustment	42222	08ADh
Ch2 Cold junction compensation	42223	08AEh
Ch2 Remote mode switch	42224	08AFh
Ch2 RSV zero adjustment	42225	08B0h
Ch2 RSV span adjustment	42226	08B1h
Ch2 MV1 lower limits	42255	08CEh
Ch2 MV1 upper limits	42256	08CFh
Ch2 MV2 lower limits	42257	08D0h
Ch2 MV2 upper limits	42258	08D1h
Ch2 Output limiter type setting	42259	08D2h
Ch2 FAULT MV1 set value	42260	08D3h
Ch2 FAULT MV2 set value	42261	08D4h

Content	Register number	Relative address
Ch2 Soft start MV1 value	42262	08D5h
Ch2 Soft start MV2 value	42263	08D6h
Ch2 Soft start time	42264	08D7h
Ch2 Standby MV1 value	42268	08DBh
Ch2 Standby MV2 value	42269	08DCh
Ch2 Standby mode setting	42270	08DDh
Ch2 Control algorithm	42291	08F2h
Ch2 ON/OFF hysteresis setting	42292	08F3h
Ch2 Ramp SV ON/OFF	42299	08FAh
Ch2 Ramp SV - decline	42300	08FBh
Ch2 Ramp SV - incline	42301	08FCh
Ch2 Ramp SV slope time units	42302	08FDh
Ch2 Mode at startup	42304	08FFh
Ch2 Control when input burnout is detected	42407	0966h
Ch2 RSV input master Station No.	42532	09E3h
Ch2 RSV input master Ch. No.	42533	09E4h
Ch2 Linkage operation master Station No.	42536	09E7h
Ch2 Linkage operation master Ch. No.	42537	09E8h
Out2 Current output range	42801	0AF0h
Out2 Output type	42803	0AF2h
Out2 Output master station No.	42804	0AF3h
Out2 Output master Ch. No.	42805	0AF4h
Out2 Output scaling span	42806	0AF5h
Out2 Output scaling base	42807	0AF6h
Ch3 Local SV value	43001	0BB8h
Ch3 MV value	43002	0BB9h
Ch3 Manual mode switch	43003	0BBAh
Ch3 RUN/Standby switch	43004	0BBBh
Ch3 Auto-tuning RUN command	43005	0BBCh
Ch3 Remote mode switch	43007	0BBEh
Ch3 DI master Station No. setting	43011	0BC2h
Ch3 DI-1 function select	43013	0BC4h
Ch3 DI-2 function select	43014	0BC5h
Ch3 DI-3 function select	43015	0BC6h
Ch3 DI-4 function select	43016	0BC7h
Ch3 DI-5 function select	43017	0BC8h
Ch3 DI-6 function select	43018	0BC9h
Ch3 DI-7 function select	43019	0BCAh
Ch3 DI-8 function select	43020	0BCBh
Ch3 DI-9 function select	43021	0BCCh
Ch3 DI-10 function select	43022	0BCDh
Ch3 DI-11 function select	43023	0BCEh
Ch3 DI-12 function select	43024	0BCFh
Ch3 DI-13 function select	43025	0BD0h
Ch3 DI-14 function select	43026	0BD1h
Ch3 DI-15 function select	43027	0BD2h
Ch3 DI-16 function select	43028	0BD3h
Out3 PV input type	43029	0BD4h
Ch3 Digital output latch release command	43031	0BD6h

5.7 Address Map and Data Format

Content	Register number	Relative address
Ch3 DO1 output event type setting	43032	0BD7h
Ch3 ALM1 set value 1	43033	0BD8h
Ch3 ALM1 set value 2	43034	0BD9h
Ch3 ALM1 hysteresis	43035	0BDAh
Ch3 DO1 option function setting	43036	0BDBh
Ch3 ALM1 delay time	43037	0BDCh
Ch3 ALM1 delay time units	43038	0BDDh
Ch3 Object Ch. No. for interchannel ALM1	43039	0BDEh
Ch3 DO2 output event type setting	43040	0BDFh
Ch3 ALM2 set value 1	43041	0BE0h
Ch3 ALM2 set value 2	43042	0BE1h
Ch3 ALM2 hysteresis	43043	0BE2h
Ch3 DO2 option function setting	43044	0BE3h
Ch3 ALM2 delay time	43045	0BE4h
Ch3 ALM2 delay time units	43046	0BE5h
Ch3 Object Ch. No. for interchannel ALM2	43047	0BE6h
Ch3 DO3 output event type setting	43048	0BE7h
Ch3 ALM3 set value 1	43049	0BE8h
Ch3 ALM3 set value 2	43050	0BE9h
Ch3 ALM3 hysteresis	43051	0BEAh
Ch3 DO3 option function setting	43052	0BEBh
Ch3 ALM3 delay time	43053	0BECCh
Ch3 ALM3 delay time units	43054	0BEDh
Ch3 Object Ch. No. for interchannel ALM3	43055	0BEEh
Ch3 DO4 output event type setting	43056	0BEFh
Ch3 ALM4 set value 1	43057	0BF0h
Ch3 ALM4 set value 2	43058	0BF1h
Ch3 ALM4 hysteresis	43059	0BF2h
Ch3 DO4 option function setting	43060	0BF3h
Ch3 ALM4 delay time	43061	0BF4h
Ch3 ALM4 delay time units	43062	0BF5h
Ch3 Object Ch. No. for interchannel ALM4	43063	0BF6h
Ch3 DO5 output event type setting	43064	0BF7h
Ch3 ALM5 set value 1	43065	0BF8h
Ch3 ALM5 set value 2	43066	0BF9h
Ch3 ALM5 hysteresis	43067	0BFAh
Ch3 DO5 option function setting	43068	0BFBh
Ch3 ALM5 delay time	43069	0BFCh
Ch3 ALM5 delay time units	43070	0BFDh
Ch3 Object Ch. No. for interchannel ALM5	43071	0BFEh
Ch3 CT[A] HB alarm set value	43072	0BFFh
Ch3 CT[A] HB alarm hysteresis	43073	0C00h
Ch3 CT[A] load short-circuit alarm set value	43074	0C01h
Ch3 CT[A] load short-circuit alarm hysteresis	43075	0C02h

Content	Register number	Relative address
Ch3 CT[B] HB alarm set value	43076	0C03h
Ch3 CT[B] HB alarm hysteresis	43077	0C04h
Ch3 CT[B] load short-circuit alarm set value	43078	0C05h
Ch3 CT[B] load short-circuit alarm hysteresis	43079	0C06h
Ch3 Loop break detection time	43080	0C07h
Ch3 Loop break detection band	43081	0C08h
Ch3 Communication SV value	43100	0C1Bh
Ch3 Local SV value	43101	0C1Ch
Ch3 Proportional band [P]	43102	0C1Dh
Ch3 Integration time [I]	43103	0C1Eh
Ch3 Derivation time [D]	43104	0C1Fh
Ch3 ON/OFF control hysteresis	43105	0C20h
Ch3 Cooling proportional band coefficient [cool]	43106	0C21h
Ch3 Dead band	43107	0C22h
Ch3 Output convergence value	43108	0C23h
Ch3 Anti-reset windup [ARW]	43109	0C24h
Ch3 Direct/reverse action setting [MV1/MV2]	43110	0C25h
Ch3 PV input scale lower	43212	0C8Bh
Ch3 PV input scale upper	43213	0C8Ch
Ch3 Decimal place	43214	0C8Dh
Ch3 Temperature unit	43215	0C8Eh
Ch3 PV input shift	43216	0C8Fh
Ch3 SV value shift	43217	0C90h
Ch3 SV lower limits	43218	0C91h
Ch3 SV upper limits	43219	0C92h
Ch3 PV input filter	43220	0C93h
Ch3 PV display zero adjustment	43221	0C94h
Ch3 PV display span adjustment	43222	0C95h
Ch3 Cold junction compensation	43223	0C96h
Ch3 Remote mode switch	43224	0C97h
Ch3 RSV zero adjustment	43225	0C98h
Ch3 RSV span adjustment	43226	0C99h
Ch3 MV1 lower limits	43255	0CB6h
Ch3 MV1 upper limits	43256	0CB7h
Ch3 MV2 lower limits	43257	0CB8h
Ch3 MV2 upper limits	43258	0CB9h
Ch3 Output limiter type setting	43259	0CBAh
Ch3 FAULT MV1 set value	43260	0CBBh
Ch3 FAULT MV2 set value	43261	0CBCCh
Ch3 Soft start MV1 value	43262	0CBDh
Ch3 Soft start MV2 value	43263	0CBEh
Ch3 Soft start time	43264	0CBFh
Ch3 Standby MV1 value	43268	0CC3h
Ch3 Standby MV2 value	43269	0CC4h
Ch3 Standby mode setting	43270	0CC5h
Ch3 Control algorithm	43291	0CDAh
Ch3 ON/OFF hysteresis setting	43292	0CDBh
Ch3 Ramp SV ON/OFF	43299	0CE2h
Ch3 Ramp SV - decline	43300	0CE3h
Ch3 Ramp SV - incline	43301	0CE4h
Ch3 Ramp SV slope time units	43302	0CE5h
Ch3 Mode at startup	43304	0CE7h

Content	Register number	Relative address
Ch3 Control when input burnout is detected	43407	0D4Eh
Ch3 RSV input master Station No.	43532	0DCBh
Ch3 RSV input master Ch. No.	43533	0DCCh
Ch3 Linkage operation master Station No.	43536	0DCFh
Ch3 Linkage operation master Ch. No.	43537	0DD0h
Out3 Current output range	43801	0ED8h
Out3 Output type	43803	0EDAh
Out3 Output master Station No.	43804	0EDBh
Out3 Output master Ch. No.	43805	0EDCh
Out3 Output scaling span	43806	0EDDh
Out3 Output scaling base	43807	0EDEh
Ch4 Local SV value	44001	0FA0h
Ch4 MV value	44002	0FA1h
Ch4 Manual mode switch	44003	0FA2h
Ch4 RUN/Standby switch	44004	0FA3h
Ch4 Auto-tuning RUN command	44005	0FA4h
Ch4 Remote mode switch	44007	0FA6h
Ch4 DI master Station No. setting	44011	0FAAh
Ch4 DI-1 function select	44013	0FACH
Ch4 DI-2 function select	44014	0FADh
Ch4 DI-3 function select	44015	0FAEh
Ch4 DI-4 function select	44016	0FAFh
Ch4 DI-5 function select	44017	0FB0h
Ch4 DI-6 function select	44018	0FB1h
Ch4 DI-7 function select	44019	0FB2h
Ch4 DI-8 function select	44020	0FB3h
Ch4 DI-9 function select	44021	0FB4h
Ch4 DI-10 function select	44022	0FB5h
Ch4 DI-11 function select	44023	0FB6h
Ch4 DI-12 function select	44024	0FB7h
Ch4 DI-13 function select	44025	0FB8h
Ch4 DI-14 function select	44026	0FB9h
Ch4 DI-15 function select	44027	0FBAh
Ch4 DI-16 function select	44028	0FBBh
Out4 PV input type	44029	0FBCh
Ch4 Digital output latch release command	44031	0FBEh
Ch4 DO1 output event type setting	44032	0FBFh
Ch4 ALM1 set value 1	44033	0FC0h
Ch4 ALM1 set value 2	44034	0FC1h
Ch4 ALM1 hysteresis	44035	0FC2h
Ch4 DO1 option function setting	44036	0FC3h
Ch4 ALM1 delay time	44037	0FC4h
Ch4 ALM1 delay time units	44038	0FC5h
Ch4 Object Ch. No. for interchannel ALM1	44039	0FC6h
Ch4 DO2 output event type setting	44040	0FC7h
Ch4 ALM2 set value 1	44041	0FC8h
Ch4 ALM2 set value 2	44042	0FC9h

Content	Register number	Relative address
Ch4 ALM2 hysteresis	44043	0FCAh
Ch4 DO2 option function setting	44044	0FCBh
Ch4 ALM2 delay time	44045	0FCCh
Ch4 ALM2 delay time units	44046	0FCDh
Ch4 Object Ch. No. for interchannel ALM2	44047	0FCEh
Ch4 DO3 output event type setting	44048	0FCFh
Ch4 ALM3 set value 1	44049	0FD0h
Ch4 ALM3 set value 2	44050	0FD1h
Ch4 ALM3 hysteresis	44051	0FD2h
Ch4 DO3 option function setting	44052	0FD3h
Ch4 ALM3 delay time	44053	0FD4h
Ch4 ALM3 delay time units	44054	0FD5h
Ch4 Object Ch. No. for interchannel ALM3	44055	0FD6h
Ch4 DO4 output event type setting	44056	0FD7h
Ch4 ALM4 set value 1	44057	0FD8h
Ch4 ALM4 set value 2	44058	0FD9h
Ch4 ALM4 hysteresis	44059	0FDAh
Ch4 DO4 option function setting	44060	0FDBh
Ch4 ALM4 delay time	44061	0FDCCh
Ch4 ALM4 delay time units	44062	0FDDh
Ch4 Object Ch. No. for interchannel ALM4	44063	0FDEh
Ch4 DO5 output event type setting	44064	0FDFh
Ch4 ALM5 set value 1	44065	0FE0h
Ch4 ALM5 set value 2	44066	0FE1h
Ch4 ALM5 hysteresis	44067	0FE2h
Ch4 DO5 option function setting	44068	0FE3h
Ch4 ALM5 delay time	44069	0FE4h
Ch4 ALM5 delay time units	44070	0FE5h
Ch4 Object Ch. No. for interchannel ALM5	44071	0FE6h
Ch4 CT[A] HB alarm set value	44072	0FE7h
Ch4 CT[A] HB alarm hysteresis	44073	0FE8h
Ch4 CT[A] load short-circuit alarm set value	44074	0FE9h
Ch4 CT[A] load short-circuit alarm hysteresis	44075	0FEAh
Ch4 CT[B] HB alarm set value	44076	0FEBh
Ch4 CT[B] HB alarm hysteresis	44077	0FECh
Ch4 CT[B] load short-circuit alarm set value	44078	0FEDh
Ch4 CT[B] load short-circuit alarm hysteresis	44079	0FEEh
Ch4 Loop break detection time	44080	0FEFh
Ch4 Loop break detection band	44081	0FF0h
Ch4 Communication SV value	44100	1003h
Ch4 Local SV value	44101	1004h
Ch4 Proportional band [P]	44102	1005h
Ch4 Integration time [I]	44103	1006h
Ch4 Derivation time [D]	44104	1007h
Ch4 ON/OFF control hysteresis	44105	1008h

5.7 Address Map and Data Format

Content	Register number	Relative address
Ch4 Cooling proportional band coefficient [cool]	44106	1009h
Ch4 Dead band	44107	100Ah
Ch4 Output convergence value	44108	100Bh
Ch4 Anti-reset windup [ARW]	44109	100Ch
Ch4 Direct/reverse action setting [MV1/MV2]	44110	100Dh
Ch4 PV input scale lower	44212	1073h
Ch4 PV input scale upper	44213	1074h
Ch4 Decimal place	44214	1075h
Ch4 Temperature unit	44215	1076h
Ch4 PV input shift	44216	1077h
Ch4 SV value shift	44217	1078h
Ch4 SV lower limits	44218	1079h
Ch4 SV upper limits	44219	107Ah
Ch4 PV input filter	44220	107Bh
Ch4 PV display zero adjustment	44221	107Ch
Ch4 PV display span adjustment	44222	107Dh
Ch4 Cold junction compensation	44223	107Eh
Ch4 Remote mode switch	44224	107Fh
Ch4 RSV zero adjustment	44225	1080h
Ch4 RSV span adjustment	44226	1081h
Ch4 MV1 lower limits	44255	109Eh
Ch4 MV1 upper limits	44256	109Fh
Ch4 MV2 lower limits	44257	10A0h
Ch4 MV2 upper limits	44258	10A1h
Ch4 Output limiter type setting	44259	10A2h
Ch4 FAULT MV1 set value	44260	10A3h
Ch4 FAULT MV2 set value	44261	10A4h
Ch4 Soft start MV1 value	44262	10A5h
Ch4 Soft start MV2 value	44263	10A6h
Ch4 Soft start time	44264	10A7h
Ch4 Standby MV1 value	44268	10ABh
Ch4 Standby MV2 value	44269	10ACh
Ch4 Standby mode setting	44270	10ADh
Ch4 Control algorithm	44291	10C2h
Ch4 ON/OFF hysteresis setting	44292	10C3h
Ch4 Ramp SV ON/OFF	44299	10CAh
Ch4 Ramp SV - decline	44300	10CBh
Ch4 Ramp SV - incline	44301	10CCh
Ch4 Ramp SV slope time units	44302	10CDh
Ch4 Mode at startup	44304	10CFh
Ch4 Control when input burnout is detected	44407	1136h
Ch4 RSV input master Station No.	44532	11B3h
Ch4 RSV input master Ch. No.	44533	11B4h
Ch4 Linkage operation master Station No.	44536	11B7h
Ch4 Linkage operation master Ch. No.	44537	11B8h
Out4 Current output range	44801	12C0h
Out4 Output type	44803	12C2h
Out4 Output master Station No.	44804	12C3h
Out4 Output master Ch. No.	44805	12C4h
Out4 Output scaling span	44806	12C5h

Content	Register number	Relative address
Out4 Output scaling base	44807	12C6h
User data 01	45001	1388h
User data 02	45002	1389h
User data 03	45003	138Ah
User data 04	45004	138Bh
User data 05	45005	138Ch
User data 06	45006	138Dh
User data 07	45007	138Eh
User data 08	45008	138Fh
User data 09	45009	1390h
User data 10	45010	1391h
User data 11	45011	1392h
User data 12	45012	1393h
User data 13	45013	1394h
User data 14	45014	1395h
User data 15	45015	1396h
User data 16	45016	1397h
User data 17	45017	1398h
User data 18	45018	1399h
User data 19	45019	139Ah
User data 20	45020	139Bh
User data 21	45021	139Ch
User data 22	45022	139Dh
User data 23	45023	139Eh
User data 24	45024	139Fh
User data 25	45025	13A0h
User data 26	45026	13A1h
User data 27	45027	13A2h
User data 28	45028	13A3h
User data 29	45029	13A4h
User data 30	45030	13A5h
User data 31	45031	13A6h
User data 32	45032	13A7h
System time	30001	0000h
Ch1 Measurement value (PV)	30002	0001h
Ch2 Measurement value (PV)	30003	0002h
Ch3 Measurement value (PV)	30004	0003h
Ch4 Measurement value (PV)	30005	0004h
Ch1 Set value (SV)	30006	0005h
Ch2 Set value (SV)	30007	0006h
Ch3 Set value (SV)	30008	0007h
Ch4 Set value (SV)	30009	0008h
Ch1 DV	30010	0009h
Ch2 DV	30011	000Ah
Ch3 DV	30012	000Bh
Ch4 DV	30013	000Ch
Ch1 Output value (MV1)	30014	000Dh
Ch1 Output value (MV2)	30015	000Eh
Ch2 Output value (MV1)	30016	000Fh
Ch2 Output value (MV2)	30017	0010h
Ch3 Output value (MV1)	30018	0011h
Ch3 Output value (MV2)	30019	0012h
Ch4 Output value (MV1)	30020	0013h
Ch4 Output value (MV2)	30021	0014h
Ch1 Remote SV (RSV)	30022	0015h
Ch2 Remote SV (RSV)	30023	0016h

Content	Register number	Relative address
Ch3 Remote SV (RSV)	30024	0017h
Ch4 Remote SV (RSV)	30025	0018h
Ch1 Remote mode switch	30030	001Dh
Ch2 Remote mode switch	30031	001Eh
Ch3 Remote mode switch	30032	001Fh
Ch4 Remote mode switch	30033	0020h
RS-485 Communication permission	30062	003Dh
Ch1 Heater current [A]	30071	0046h
Ch1 Heater current [B]	30072	0047h
Ch2 Heater current [A]	30073	0048h
Ch2 Heater current [B]	30074	0049h
Ch3 Heater current [A]	30075	004Ah
Ch3 Heater current [B]	30076	004Bh
Ch4 Heater current [A]	30077	004Ch
Ch4 Heater current [B]	30078	004Dh
Ch1 Leak current [A]	30081	0050h
Ch1 Leak current [B]	30082	0051h
Ch2 Leak current [A]	30083	0052h
Ch2 Leak current [B]	30084	0053h
Ch3 Leak current [A]	30085	0054h
Ch3 Leak current [B]	30086	0055h
Ch4 Leak current [A]	30087	0056h
Ch4 Leak current [B]	30088	0057h
Ch1 RCJtemp	30110	006Dh
Ch2 RCJtemp	30111	006Eh
Ch3 RCJtemp	30112	006Fh
Ch4 RCJtemp	30113	0070h
Out1 Output value	30120	0077h
Out2 Output value	30121	0078h
Out3 Output value	30122	0079h
Out4 Output value	30123	007Ah
Ch1 SV value	30905	0388h
Ch2 SV value	30906	0389h
Ch3 SV value	30907	038Ah
Ch4 SV value	30908	038Bh
Ch1 Measurement value (PV)	31001	03E8h
Ch1 Set value (SV)	31002	03E9h
Ch1 DV	31003	03EAh
Ch1 Output value (MV1)	31004	03EBh
Ch1 Output value (MV2)	31005	03ECh
Ch1 Alarm 1-5 status	31007	03EEh
Ch1 Error source display	31008	03EFh
Ch1 Remaining time on timer 1	31011	03F2h
Ch1 Remaining time on timer 2	31012	03F3h
Ch1 Remaining time on timer 3	31013	03F4h
Ch1 Remaining time on timer 4	31014	03F5h
Ch1 Remaining time on timer 5	31015	03F6h
Ch1 RCJtemp	31016	03F7h
Ch1 Remote mode switch	31037	040Ch
Ch1 Remote SV (RSV)	31045	0414h
Ch1 Heater current [A]	31046	0415h
Ch1 Heater current [B]	31047	0416h
Ch1 Leak current [A]	31048	0417h
Ch1 Leak current [B]	31049	0418h
Ch1 Error source display	31054	041Dh

Content	Register number	Relative address
Ch1 Alarm 1-5 status	31060	0423h
Ch1 Event input status	31061	0424h
Ch2 Measurement value (PV)	32001	07D0h
Ch2 Set value (SV)	32002	07D1h
Ch2 DV	32003	07D2h
Ch2 Output value (MV1)	32004	07D3h
Ch2 Output value (MV2)	32005	07D4h
Ch2 Alarm 1-5 status	32007	07D6h
Ch2 Error source display	32008	07D7h
Ch2 Remaining time on timer 1	32011	07DAh
Ch2 Remaining time on timer 2	32012	07DBh
Ch2 Remaining time on timer 3	32013	07DCh
Ch2 Remaining time on timer 4	32014	07DDh
Ch2 Remaining time on timer 5	32015	07DEh
Ch2 RCJtemp	32016	07DFh
Ch2 Remote mode switch	32037	07F4h
Ch2 Remote SV (RSV)	32045	07FCh
Ch2 Heater current [A]	32046	07FDh
Ch2 Heater current [B]	32047	07FEh
Ch2 Leak current [A]	32048	07FFh
Ch2 Leak current [B]	32049	0800h
Ch2 Error source display	32054	0805h
Ch2 Alarm 1-5 status	32060	080Bh
Ch2 Event input status	32061	080Ch
Ch3 Measurement value (PV)	33001	0BB8h
Ch3 Set value (SV)	33002	0BB9h
Ch3 DV	33003	0BBAh
Ch3 Output value (MV1)	33004	0BBBh
Ch3 Output value (MV2)	33005	0BBCh
Ch3 Alarm 1-5 status	33007	0BBEh
Ch3 Error source display	33008	0BBFh
Ch3 Remaining time on timer 1	33011	0BC2h
Ch3 Remaining time on timer 2	33012	0BC3h
Ch3 Remaining time on timer 3	33013	0BC4h
Ch3 Remaining time on timer 4	33014	0BC5h
Ch3 Remaining time on timer 5	33015	0BC6h
Ch3 RCJtemp	33016	0BC7h
Ch3 Remote mode switch	33037	0BDCh
Ch3 Remote SV (RSV)	33045	0BE4h
Ch3 Heater current [A]	33046	0BE5h
Ch3 Heater current [B]	33047	0BE6h
Ch3 Leak current [A]	33048	0BE7h
Ch3 Leak current [B]	33049	0BE8h
Ch3 Error source display	33054	0BEDh
Ch3 Alarm 1-5 status	33060	0BF3h
Ch3 Event input status	33061	0BF4h
Ch4 Measurement value (PV)	34001	0FA0h
Ch4 Set value (SV)	34002	0FA1h
Ch4 DV	34003	0FA2h
Ch4 Output value (MV1)	34004	0FA3h
Ch4 Output value (MV2)	34005	0FA4h
Ch4 Alarm 1-5 status	34007	0FA6h
Ch4 Error source display	34008	0FA7h
Ch4 Remaining time on timer 1	34011	0FAAh
Ch4 Remaining time on timer 2	34012	0FABh
Ch4 Remaining time on timer 3	34013	0FACh

5.7 Address Map and Data Format

Content	Register number	Relative address
Ch4 Remaining time on timer 4	34014	0FADh
Ch4 Remaining time on timer 5	34015	0FAEh
Ch4 RCJtemp	34016	0FAFh
Ch4 Remote mode switch	34037	0FC4h
Ch4 Remote SV (RSV)	34045	0FCCh
Ch4 Heater current [A]	34046	0FCDh
Ch4 Heater current [B]	34047	0FCEh
Ch4 Leak current [A]	34048	0FCFh
Ch4 Leak current [B]	34049	0FD0h
Ch4 Error source display	34054	0FD5h
Ch4 Alarm 1-5 status	34060	0FDBh
Ch4 Event input status	34061	0FDCh

5.8 Sample Program

A sample program for reading and writing data that runs on Microsoft Visual Basic 6.0 (SP6) is distributed in our home page.

The sample program is meant to be used as a reference for your own program creation, and therefore all its actions are not guaranteed.

Sample program body can be downloaded from our home page indicated below.

Home page address : <http://www.fic-net.jp/> PUM_Sample_program.lzh

Before running the program, check the following summary of points for communication conditions.

- Parity, communication speed to be set in this program. Please match these values with the conditions of the PUM.

Warning when using an RS-232C to RS-485 converter

The sent data is sometimes added to the response data from the slave before it is received. In this case, when receiving the data, process the response data only after first getting rid of the number of bytes from the sent data.

Compatible OS

Windows 2000 Professional

Windows XP Professional Edition

Note

- Windows® is a registered trademark of the Microsoft Corporation.
- Visual Basic® is a registered trademark of the Microsoft Corporation.

Fuji Electric Systems Co., Ltd. assumes no responsibility for damages or infringement upon third party rights as a result of using this sample program. Use this program while conforming to the contents of the agreement listed within.

6

Troubleshooting

6.1 Troubleshooting Procedures 6-3

6.1 Troubleshooting Procedures

Troubles that May Occur when the Loader Software is Connected

The following table lists troubles that may occur when module setting is made using a loader software and remedies against such troubles.

Also see the instruction manual of the loader software.

Trouble	Causes	Solution
None of the connected modules is capable of communicating with the loader software.	Improper loader software connection	Check that the loader software and the modules are connected properly.
	Cables connected to the loader software are defective.	Replace the cables connected to the loader software.
	Improper station No. setting	Check station No. of module that connected with loader software.
	Incompatible communication conditions	Check that the communication specifications of the loader software and those of the module are compatible.
Some of the connected modules only cannot communicate with the loader software.	Improper loader software connection	Check that the loader software is connected to the master of the internal communication between modules.
	Improper station No. setting	Check that none of the station Nos. is set duplicated.
Parameters cannot be changed.	“RS-485 communication permission setting” is set to “Read only.”	Set “RS-485 communication permission setting” to “Read/Write.”

Troubles during Operation

If trouble should occur during operation, check the type of your module and its connection as well as parameter setting for any abnormalities. The following table lists typical trouble and measures to be taken against them.

At power ON

Trouble	Causes	Solution
The PWR indicator does not come on even if the power is turned on.	Power is not supplied to the main unit.	Check that power supply wiring is installed.
	Power supply voltage does not fall within the permissible range.	Use a power supply conforming to the module specifications.
	Main unit failure	Replace the module.
Control is not started properly even if the power is turned on.	“mode at startup” setting is set to Manual or Standby.	Check “mode at startup” setting.
An alarm is output on turning on the power.	Setting has been made to allow the alarm range to be entered when operation for production is not performed.	Check the values set as alarm operation points. Change the type of alarms to the one provided with the hold function as required.

At start of operation

Trouble	Causes	Solution
The PV value exceeds the upper or lower limit.	Improper sensor connection	Check that the sensor is connected to the input terminal, and that the polarity is not reversed.
	Sensor failure (break or degradation)	Replace the sensor.
	Too long compensating lead wire from the sensor causes conductor resistance to affect the reading.	Use a thick compensating lead wire. Keep wiring as short as possible by changing the sensor position.
	Improper input settings	Check input type and input correction.
Improper output (control output or retransmission output)	Improper control setting	Check the parameter of PID and "direct/reverse action" setting. Perform Auto tuning as required.
	Output is limited	Make output limiter setting and select output limiter type.
	Standby or Manual mode is selected.	Check the control mode currently selected.
	Improper output setting	Check the Output master station No., Output master Ch, and output type.
	Output is shut down.	Check the output shutdown setting.
Event input from Event I/O module cannot be made.	Digital input master station No. has not been set.	Check the Digital input master station No. setting.
Event output from Event I/O module cannot be made.	Digital output master has not been set.	Check Digital output master station No. and Digital output master Ch.
Alarm output is latched.	Alarm latch is enabled by alarm options.	Check alarm options.
	Contact melting caused by a unit failure	Replace the module.

During operation

Trouble	Causes	Solution
Fluctuation of PV value	Effect of external noise	Take measures against noise, or provide an input filter as required.
	Inappropriate parameter of PID.	Perform Auto tuning.
PV value does not change.	Sensor failure	Check the sensor, and replace it as required.
	Main unit failure	Contact us or your dealer.
Remote SV cannot be input.	Remote SV master setting error	Check the setting of remote SV master station No. and master Ch.
Alarm is output during normal operation.	Setting has been made to allow alarms to be detected during normal operation.	Check the alarm setting.
HB alarms cannot be detected.	Too low HB alarm setting	Check the HB alarm setting.
HB alarm is output during normal operation.	Too high HB alarm setting	Check the HB alarm setting.
Loop break alarm cannot be detected.	Too narrow loop break detection range	Check the Loop break alarm setting.
Loop break alarm is output during normal operation	Too wide loop break detection range	Check the Loop break alarm setting.
Abnormal LED indicator display	Abnormal internal communication between modules	<p><About the LED indicator display> If either one of the following state is reached, the "RUN" LED indicator may come on in red, indicating that the internal communication error between modules is occurring.</p> <ul style="list-style-type: none"> • Station No. is duplicated in the connected modules. • There are two or more "Master" station in the connected modules. • There is no master module designated as RSV input master station., DI input master station, output master station, and linkage operation master station.
Standby MV value is output.	(1) Operation is made in Standby and not in RUN state. (2) The upper/lower limit range of the PV input scale exceeds 10,000, causing the module to remain in standby mode.	(1) "RUN /Standby" setting is set to "0: RUN". (2) Set the upper/lower limit range of the PV input scale to less than 10,000.

Troubles with RS-485 Communication

The following table lists typical trouble in communication and measures to be taken for the case in which a host equipment is connected via RS-485.

Trouble	Causes	Solution
Communication cannot be made from the host equipment.	Improper RS-485 connection	Check the polarity of the wiring and the existence of terminating resistance.
	Improper station No. setting	Check that none of the station Nos. is duplicated.
	incompatible communication conditions	Check "RS-485 Communication speed" setting, "RS-485 Parity" setting, and "RS-485 Response interval time" setting.
Error messages are returned to the host system.	An improper address is accessed.	Check that proper addresses are accessed.
Parameters cannot be changed by way of host equipment.	Values that do not fall within the limit range are written.	Check that the values to be written fall within the limit range.
	"RS-485 communication permission" is set to "0:Read only."	Set "RS-485 communication permission" to "1:Rea/Write."

Index

Numeral

2 position control 4-33,4-37,4-40,4-41,4-43

A

Accessories 1-5,3-14
Alarm 1-5 status 4-98,4-101
Alarm hold 4-69
Alarm parameter 5-36
ALM delay time 4-65
ALM delay time units 4-66
ALM hysteresis 4-67
ALM set value 4-62
Analog input/output module
..... 2-6,2-7,2-9,3-13,4-56,4-70
Anti-reset windup setting 4-39
Auto/Manual switch 4-8,4-90
Auto-tuning RUN command 4-6,4-90

B

Base part 1-6,1-9,3-8,3-9,3-11,5-7
Break short-circuit alarm 4-60
Broadcast query 5-3
Burnout 4-53

C

CC-Link 2-9,3-6,4-84
Coil number 5-14,5-15,5-16
Cold junction compensation 4-21,4-97,4-100
Command message 5-12,5-14,5-15,5-18,5-19
Communication condition 5-10
Communication parameter 5-37
Communication specification 5-5
Communication SV value 4-4
Condition output 4-61
Configuration parameter 5-40
Connector 1-9,3-12,3-14
Control (PID) parameter 4-6,4-33,4-37,5-30
Control algorithm 4-34,4-37

Cooling proportional band coefficient 4-43
Crimp terminal 3-17
CT input connector 1-7,1-8
CT input terminal cable 1-8,3-18
Current output range 4-27
Current output 3-16,4-25

D

Dead band 4-43,4-44
Decimal place 4-15
Derivative control action 4-37,4-38
Derivative time[D] 4-37,4-38
Deviation alarm 4-58,4-73
DI function select 4-88
DI function 4-88
DI master Station No. setting 4-88
Dimensions 3-8
Direct action 4-35,4-40,4-41,4-42
Direct/Reverse setting 4-42
DO event types 4-57,4-68
DO latch release command 4-11
DO option function setting 4-68
DO output latch function 4-64,4-68
Dual control 4-42
DV (value) 4-29,4-30,4-99

E

End plates 3-14
Enhanced communication module (PUMC)
connection permission setting 4-84
Enhanced communication module 2-9,3-6,3-13
Error check code 5-14,5-15,5-17
Error input alarm function 4-68
Error source display 4-98,4-100
Event delay time 4-65
Event input status 4-98,4-102
Event input/output module
..... 2-7,2-9,3-13,4-56,4-70,4-88,4-102

Event output	4-55	Lock lever	3-10
F		Locking tab	1-9,3-11,3-12,3-15
FAULT MV set value	4-53	Loop break alarm	4-75
Frame detection	5-18	M	
Front terminal block	1-6,1-7,3-9	Manual mode switch	4-8,4-90
Function code	5-14,5-15,5-16	Master module communication method	5-18
FUZZY PID control	4-33,4-34,4-36	Master/slave setting in connected modules	4-85,5-11
H		Master/slave setting.....	2-5,4-85,5-11
HB alarm	4-77	Master	1-7,2-5,2-6,2-7,2-9,3-13,4-22, 4-28,4-85,4-88,4-92,5-3,5-12
HB hysteresis	4-78	Message composition	5-21,5-23,5-25
Heater break (HB) alarm.....	4-77	MODBUS communication protocol	5-12
Heater current value	4-78,4-97,4-98,4-100	Mode at startup.....	4-54
Heating control	4-35,4-42	Model code	1-4
Heating proportional band	4-43	Monitor parameter	5-40
Hold reset	4-68,4-69	Mounting screw hole	1-9
Host communication equipment	3-7	Mounting screw.....	3-15
I		MV alarm	4-72
Input/output monitor.....	4-96	MV upper/lower limits	4-49,4-52
Insulation	3-16	MV value	4-5,4-96,4-97,4-99,4-100
Integral control action	4-37,4-38,4-39	N	
Integration time[I]	4-37,4-38	No response	5-15,5-17,5-20
Interchannel PV deviation alarm	4-60,4-73	Non-excitation output	4-68,4-69,4-101
Intermodule communication	4-85	O	
Irregular Slave Response	5-15	ON/OFF (2 position) control	4-6,4-35
L		ON/OFF control hysteresis.....	4-40
Leak current value	4-81,4-98,4-100	ON/OFF hysteresis mode	4-41
LED display	4-103	Operation parameter	5-29
LED indicator lamp	1-7	Output convergence value	4-45
Linkage operation master channel No.....	4-92	Output limiter type	4-49
Linkage operation master Station No.	4-92	Output master Ch No.	4-28
Linkage operation setting	4-92	Output master Station No.	4-28
Load short-circuit alarm	4-80	Output proportional cycle	4-26
Loader communication port	1-6,1-7,1-8,2-3,2-4,2-5,5-7	Output scaling base	4-31
Loader connecting cable	1-8,2-4,2-5,2-6,2-7,2-9,5-3,5-7,5-9	Output scaling span	4-31
Loader interface	5-3,5-6	Output shutdown	4-32
Local SV value	4-4	Output type	4-28

Output value	4-3,4-5,4-9,4-49,4-51,4-52, 4-53,4-96,4-97,4-99,4-100	Remote SV zero adjustment	4-23
Output when input error occurred	4-53	Remote SV(RSV)	4-10,4-14,4-22,4-23, 4-47,4-54,4-71,4-97,4-100
Overlap band	4-44	Remote/local switch	4-10,4-90
P		Reset main unit	4-107
P control	4-37,4-47	Resistance bulb	3-16,4-15
PI control	4-37	Response message	5-12,5-14,5-15,5-19
PID control against open-loop	4-33,4-34,4-36	Reverse action	4-35,4-40,4-41,4-42
PID control	4-34,4-36,4-37	RS-485 communication permission setting	4-84
Power terminal	1-6,1-9,3-17	RS-485 communication speed	4-83
Process value (PV)	3-16,4-96,4-99	RS-485 parity setting	4-83
Proportional band [P]	4-34,4-35,4-37,4-38,4-43,4-44	RS-485 response interval time setting	4-86
Proportional control action	4-38	RS-485 terminal	1-9,3-17
PUM parameter loader software	1-8,2-3,3-3	Run/Standby switch	4-9,4-90
PUM Response	5-19	S	
PV absolute alarm	4-58	Sample program	5-51
PV display span adjustment	4-20	Setup parameter	5-31
PV display zero adjustment	4-20	Side connecting terminal covers	3-14
PV input filter	4-18	Single control	4-42
PV input scale	4-15	Slave	1-7,2-5,2-6,3-13,4-85,5-3, 5-8,5-11,5-12,5-15,5-17,5-20
PV input shift	4-19	Soft start MV value	4-52
PV input type	4-15	Soft start output	4-52
R		Soft start time	4-52
Ramp SV decline	4-48	SSR drive output	4-26,4-30
Ramp SV incline	4-48	Standby mode setting	4-51
Ramp SV ON/OFF setting	4-48,4-90	Standby MV	4-51
Ramp SV slope time units	4-48	Station number	2-7,3-13,4-22,4-28,4-88, 4-92,5-3,5-6,5-10,5-11,5-15
Ramp SV	4-48,4-90,4-105	SV alarm	4-71
Range alarm	4-58,4-59	SV lower/upper limit	4-46
Reading read-only word data	5-23	SV value shift	4-47
Reading word data	5-16,5-20	SV value	4-4,4-96,4-99
Recommended power supply	5	System configuration	2-3
Register number	5-14,5-20,5-42	System parameter	5-32
Relay output	4-25,4-26,4-30	T	
Remaining time on timer	4-99,4-102	Terminal layout	3-17
Remote SV master Ch No.	4-22	Terminating resistance	3-18,5-8
Remote SV master station No.	4-22	Thermocouple	3-16,3-17,4-15
Remote SV span adjustment	4-23		

Timer code.....	4-55
Transmission control steps	5-18

U

Upper/lower limit alarm	4-59
User address R/W area	4-106
User address register number specification	4-106
User address specification communication	4-106

W

Wiring for heater break detection CT	3-18
Wiring to input/output	3-16
Wiring for power supply	3-17
Wiring for RS-485.....	3-17
Writing continuous word data	5-16,5-27
Writing word data	5-16,5-25

Fuji Electric Systems Co., Ltd.

Head Office

Gate City Ohsaki, East Tower, 11-2, Osaki 1-chome,
Shinagawa-ku, Tokyo 141-0032, Japan
<http://www.fesys.co.jp/eng>

Instrumentation Div.

International Sales Dept.

No.1, Fuji-machi, Hino-city, Tokyo 191-8502, Japan
Phone: 81-42-585-6201, 6202 Fax: 81-42-585-6187
<http://www.fic-net.jp/eng>
