



## Instruction Manual

Type

PUM

Parameter loader for multi-loop  
module-type temperature controller (PUM)

**Fuji Electric Systems Co., Ltd.**

INP-TN5A0201b-E

**Head office**

Gate City Ohsaki, East Tower, 11-2, Osaki 1-chome, Shinagawa-ku, Tokyo 141-0032, Japan  
http://www.fesys.co.jp/eng

**Instrumentation Div.**

**International Sales Dept.**

No.1, Fuji-machi, Hino-city, Tokyo 191-8502, Japan  
Phone: 81-42-585-6201, 6202 Fax: 81-42-585-6187  
http://www.fic-net.jp/eng

Thank you very much for purchasing Fuji's multi-loop module-type temperature controller. Please read this instruction manual carefully before using the instrument. Make sure that this instruction manual will be handed over to the final user of this software (PUM parameter loader).

**Note**

The contents of this manual are subject to change without notice.

This manual is compiled with possible care for the purpose of accuracy, however, Fuji Electric Systems shall not be held liable for any damages, including indirect damage, caused by typographical errors, absence of information or use of information in this manual.

## Contents

1	About the copyright of this software .....	3	Favorite .....	27
2	Outline .....	3	Switching between display ON and OFF .....	30
3	Operating environment .....	3	Relevant parameters .....	32
4	Installing/uninstalling the software .....	4	Online function .....	34
	Installation .....	4	Module composition .....	36
	Uninstallation .....	8	Checking the type code .....	38
5	Connecting your PC to the module-type temperature controller .....	9	Displaying trend .....	40
	Connection with RS-232C .....	9	Copying parameters .....	42
6	Starting the PUM parameter loader .....	13	Parameter list .....	46
	Selecting mode/File selection startup mode .....	15	Uploading (Transmission from PUM to PC) .....	48
	Selecting mode/module data reception launch mode .....	17	Downloading (Transmission from PC to PUM) .....	51
7	Initial setting .....	21	Opening files .....	54
8	Parameter setting .....	23	Saving the setting in a file .....	56
	"PUM loader – PUM Parameters Support" screen .....	23	Exiting the PUM parameter loader .....	57
	Setting parameters .....	25	9 Troubleshooting .....	59

---

---

# 1 About the copyright of this software

---

The copyright of this software (PUM parameter loader) belongs to Fuji Electric Systems Co., Ltd. Reproduction of any form or distribution of this software without permission is prohibited.

## 2 Outline

---

This software (PUM parameter loader) is an auxiliary tool for setting parameters and tuning the module-type temperature controller. The setting conditions can be edited and saved with this software. By setting, editing, and saving parameters on your PC, the setting can be copied for multiple module-type temperature controllers. The PV, SV, and MV trend can also be displayed as an auxiliary tool for tuning the module-type temperature controllers.

Unless otherwise specified, the parameter loader for module-type temperature controllers (PUM) is referred to as “PUM parameter loader” or “this software” in this manual.

## 3 Operating environment

---

OS	: Windows XP (English version)
RAM	: 128M bytes or more recommended
Free hard disk space	: 500M bytes or more recommended
Display resolution	: 1024 × 768 pixels or higher
Excel	: Microsoft ® Office Excel
Reader	: Adobe Reader

### Note

---

- Windows® is a registered trademark of Microsoft Corporation.
  - Excel® is a registered trademark of Microsoft Corporation.
  - Adobe® and Reader® are registered trademarks of Adobe Systems Incorporated.
-

---

# 4 Installing/uninstalling the software

---

Install the PUM parameter loader in your PC before use. Uninstall the software if it is no longer required.

## Installation

---

Install the PUM parameter loader as follows.

- 1 Open the “PUM loader XXXX \*” folder that has been downloaded, and then double-click “setup.exe.”  
\* XXXX describes version code.
- 2 Click [Next] to continue.

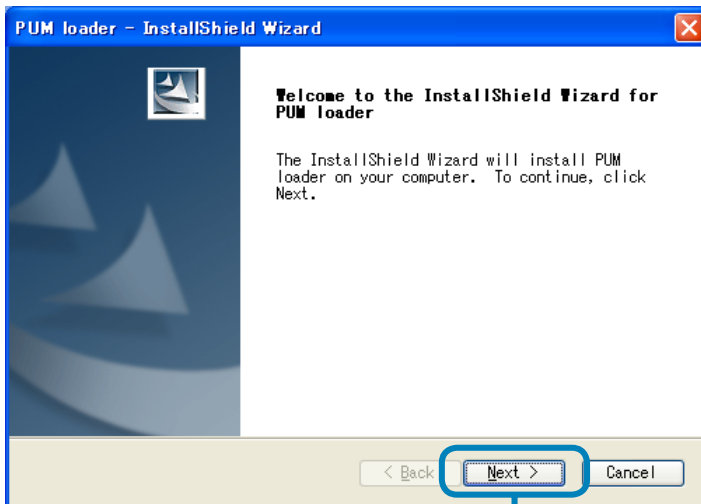

Click.

### ■ To cancel the installation

Click [Cancel].

- 3** Enter “User Name” and “Company Name”, then click [Next].



Click.

■ **To return to the previous screen**

Click [<Back].

■ **To cancel the installation**

Click [Cancel].

**Note**

You can not go to next procedure unless entry user's information.

- 4** Select set-up type, then click [Next].

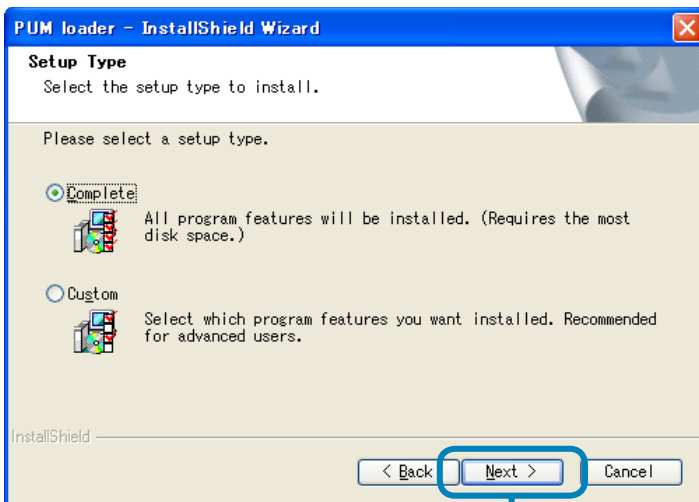

Click.

- When you selected set-up type, [all (C)] → go to **8**.
- When you selected set-up type, [Custom (S)] → go to **6**.

■ **To return to the previous screen**

Click [<Back].

■ **To cancel the installation**

Click [Cancel].

**5** Select the folder you want to install in, then click [Next].

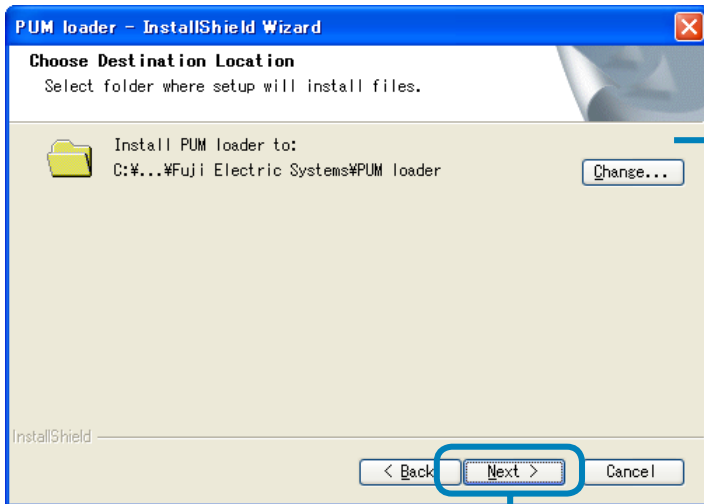

(1) Although you can change the folder you want to install in by clicking [Change], we recommended to install as the initial setting is.

(2) Click.

■ **To return to the previous screen**

Click [<Back].

■ **To cancel the installation**

Click [Cancel].

**6** Select the functions you want to install, then click [Next (N)>].

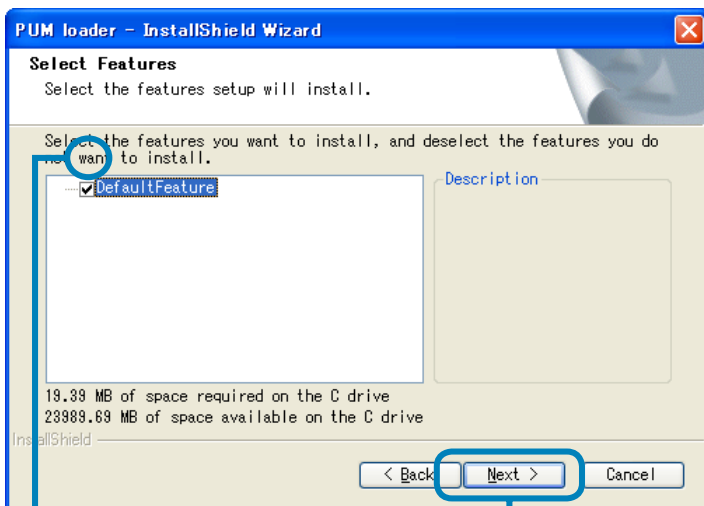

(1) You must check the box.

(2) Click.

■ **To return to the previous screen**

Click [<Back].

■ **To cancel the installation**

Click [Cancel].

**7** Click [Install].

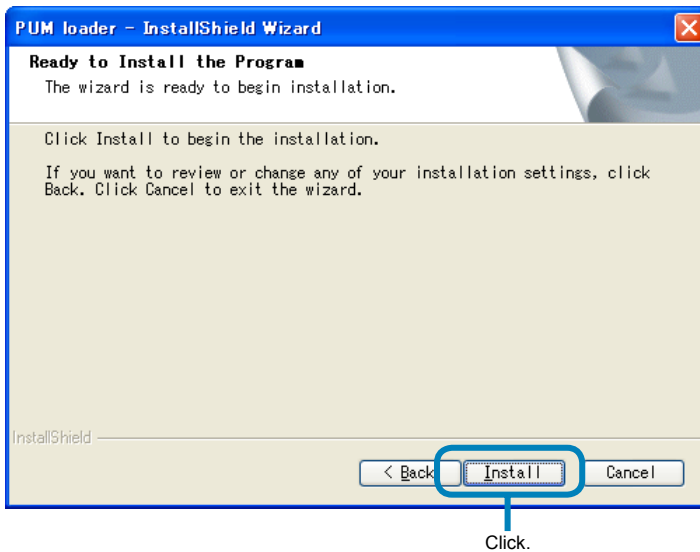

■ **To return to the previous screen**

Click [<Back].

■ **To cancel the installation**

Click [Cancel].

**8** Installation begins.

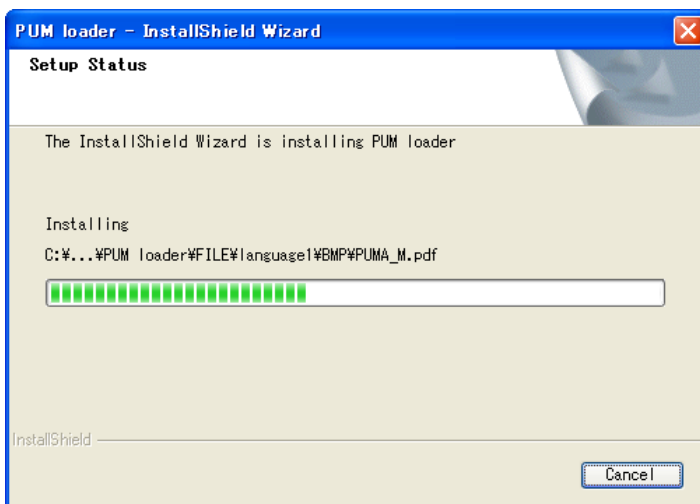

■ **To cancel the installation**

Click [Cancel].

- 
- 9 Click [Finish] to exit.

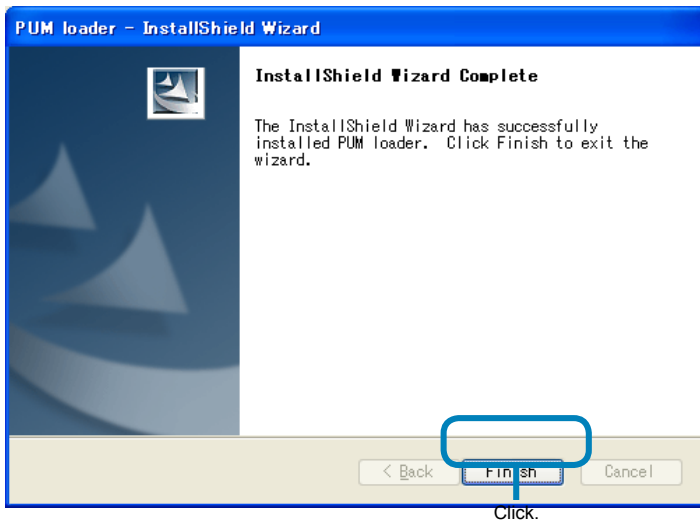

## Uninstallation

---

Select "Setting (S)" → "Control panel (C)" → "Program Add/Delete" from the start menu to uninstall the software.

# 5 Connecting your PC to the module-type temperature controller

Connect your PC to the module-type temperature controller using the RS-232C interface.

## Note

- Make the setting, being careful not to make the station Nos. of the module-type temperature controllers duplicate. The station number of the control module (PUMA/B) or the analog module is the station number configuration switch +1, and that of the event module (PUME) is the station number configuration switch +17.
- Connection via RS-485 communication is not supported.
- When operating the parameters of the enhanced communication module, connect the loader connecting cable to the loader communication port of the enhanced communication module.

## Connection with RS-232C

Provide the optionally available cable for loader connection (RS-232C, Type: PUMZ \*L01). Connect the RS-232C port (D-sub 9 pin) and the loader communication port on the front face of the module-type temperature controller with the loader connecting cable.

**[When connecting the PUM parameter loader to a control module, an event module, and an analog module]**

<Connecting a single unit>

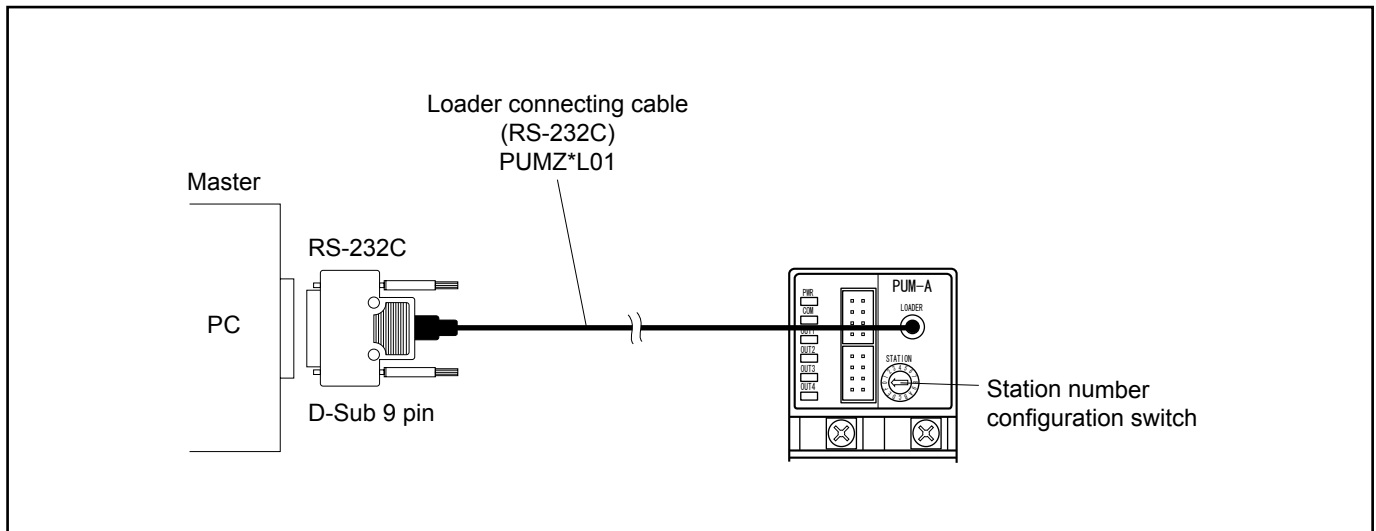

### <Connecting multiple units>

- (1) Adjust the station number configuration switch to "0" position.  
\* **The station number configuration switch can be adjusted a control/event/analog module in hexadecimal digits from 0 to F.**

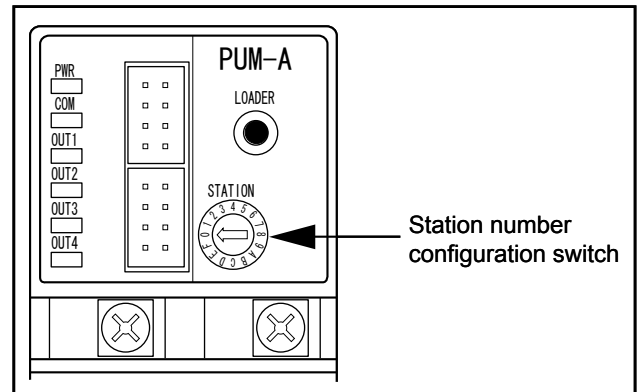

- (2) Connect one unit only first, and then select on the tree structure in the left field of the "PUM parameters Support" screen (on P. 23) "Control module → 1; Parameter → 6; Communication → 6; Master/Slave" setting connected module to "Master". (See "Parameter setting" on P. 23 for details of the setting.)  
\* **The multiple module-type temperature controller set in (2) above functions as the master..**
- (3) Connect multiple module-type temperature controllers to the one set as the master clockwise.

#### Note

Be sure to turn off the power of the module-type temperature controllers before making connections.

- (4) Set the station number configuration switches of the connected module-type temperature controllers as 1, 2, ....., F (station Nos.: 2, 3, ....., 16) consecutively from left.  
\* **Control/Analog module : Station number configuration switch set value + 1 = Station No.**  
**Event module : Station number configuration switch set value + 17 = Station No.**

#### Note

Set the station number of the control/analog module in the range of "1" to "16" without number duplication.

- (5) Following the procedure "Parameter setting" (on P.23), check that "Control module → 1; Parameter → 6; Communication → 6; Master/Slave setting connected module is set to "Slave" except for the first one, which is set to "Master."

#### Note

When all the settings are completed, turn on the power again.

## Completed connections

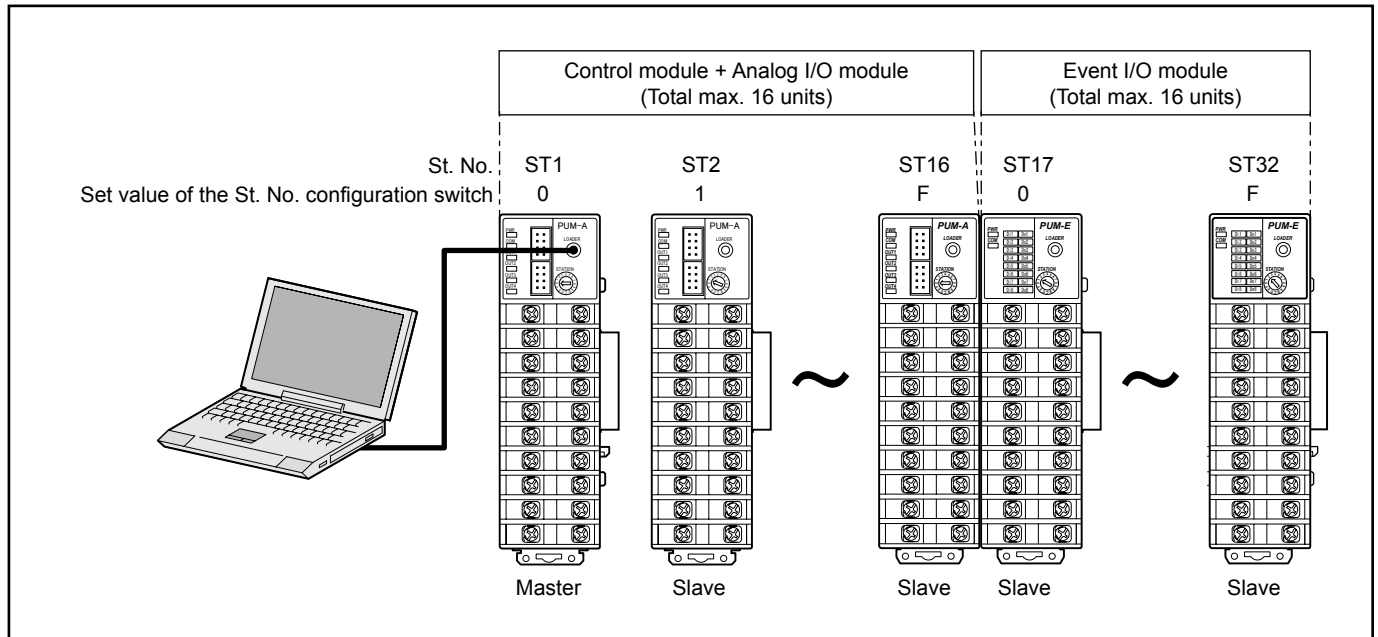

## [When connecting the PUM parameter loader to the enhanced communication module]

<Single connection>

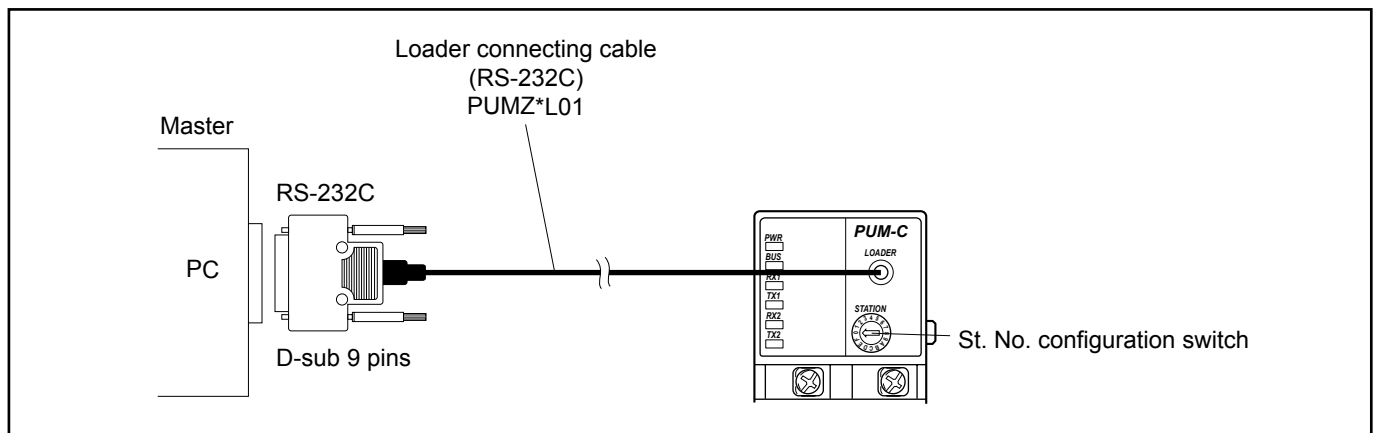

<Multiple connection>

- (1) Adjust the station number configuration switch of the enhanced communication module to "0".

\* Only "0" (fixed) can be set to the enhanced communication module.

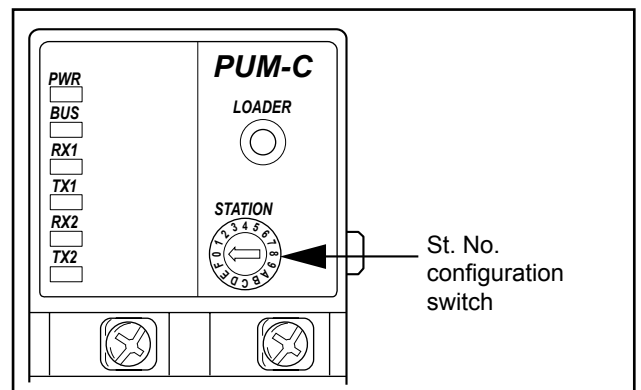

**Note**

When all the settings are completed, turn the power on again.

**<Completed connections>**

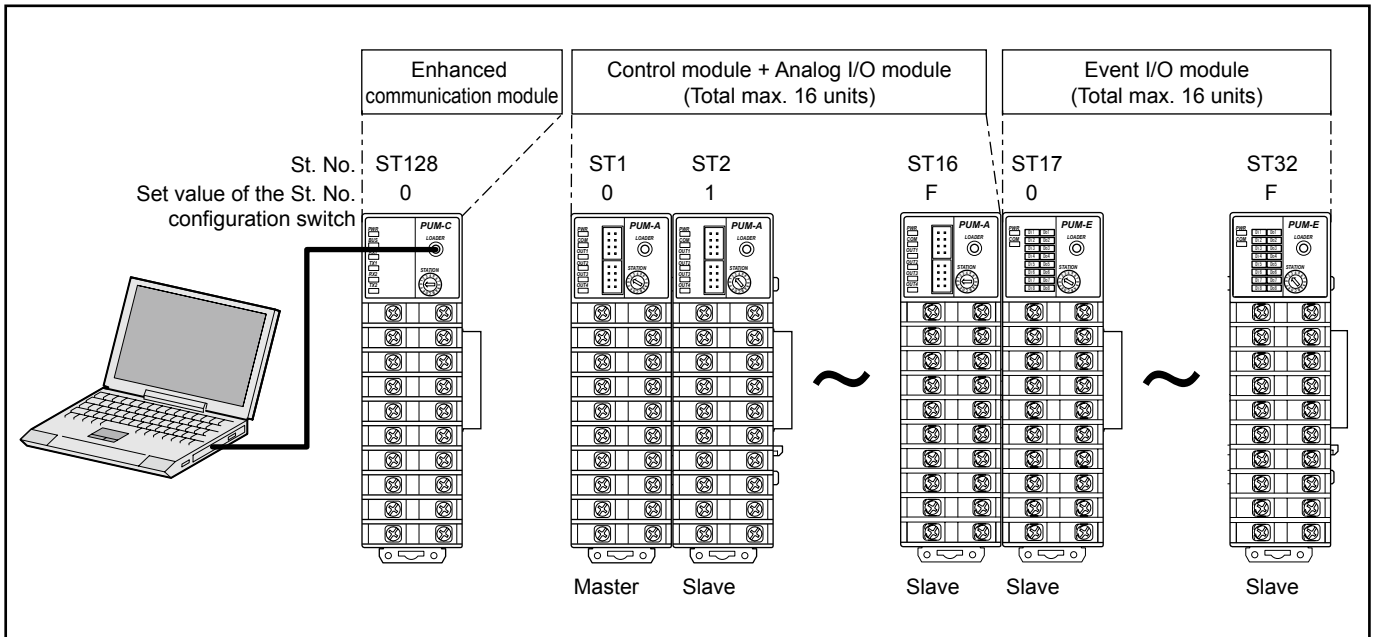

**Note**

Always place the enhanced communication module on the left of the control module set as the master.

# 6 Starting the PUM parameter loader

Select "PUM loader" on the start menu, and the following "Module type selection" screen appears.

- 1 Select the type of the module-type temperature controller you want to start on the "module type selection" screen, then click [OK].

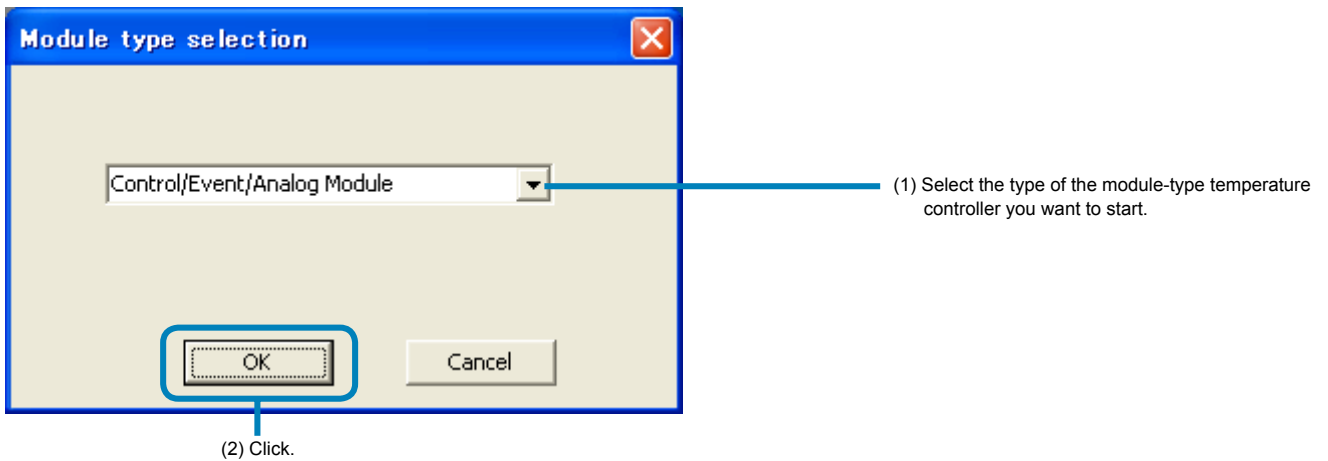

- 2 "Startup mode" screen appears.

The display screen of the control/ event/ analog module on start-up

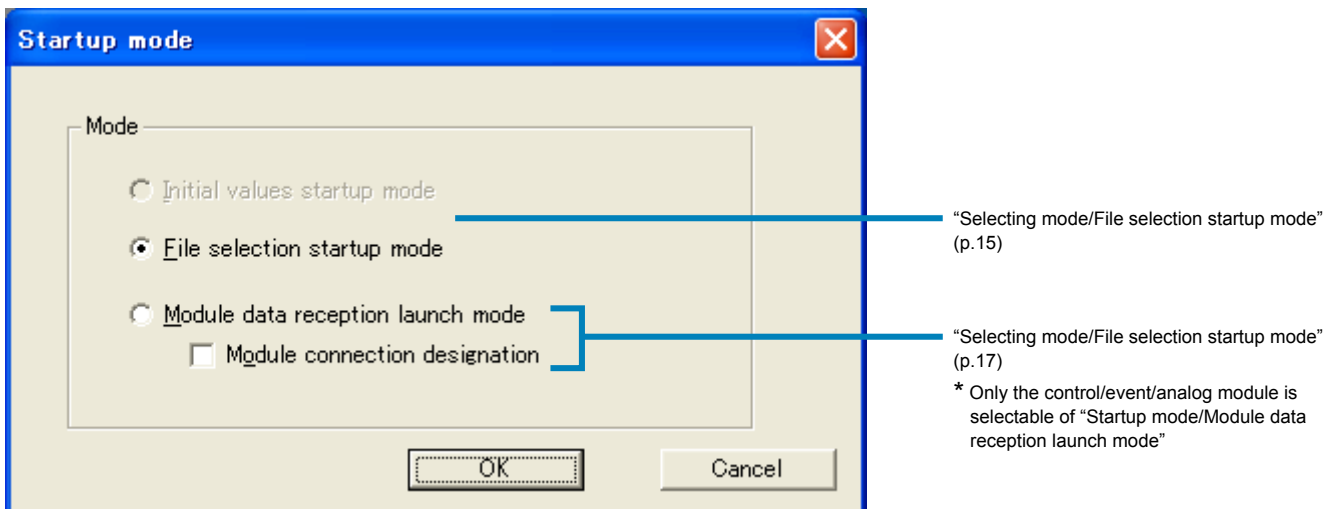

---

The display screen of the enhanced communication module on start-up

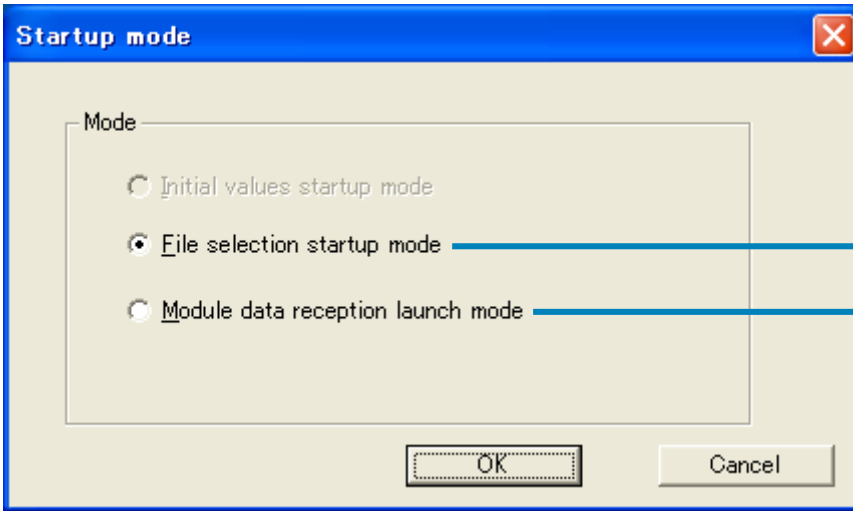

"Selecting mode/File selection startup mode"  
(p.15)

"Selecting mode/Module data reception  
launch mode" (p.17)

**Note**

If you select the module type other than the module-type temperature controller selected on the "Module type selection" screen, communication fault on start-up occurs. Select the proper module type.

---

## Selecting mode/File selection startup mode

---

Read the parameter setting file stored previously as follows.

- 1 Select "File selection startup mode" on the "Startup mode" screen, and then click [OK].

### The display screen of the control/event/analog module on start-up

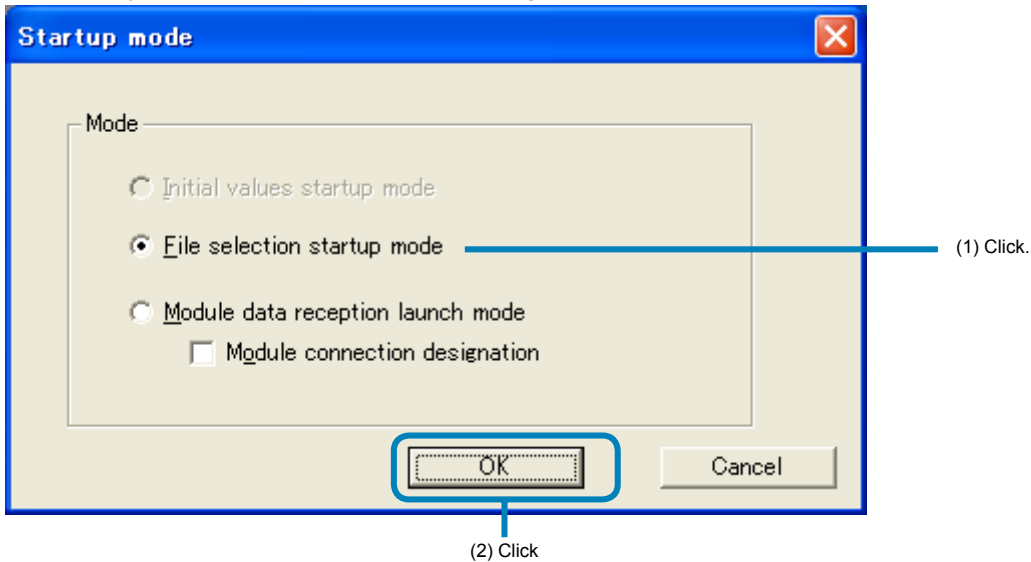

### The display screen of the enhanced communication module on start-up

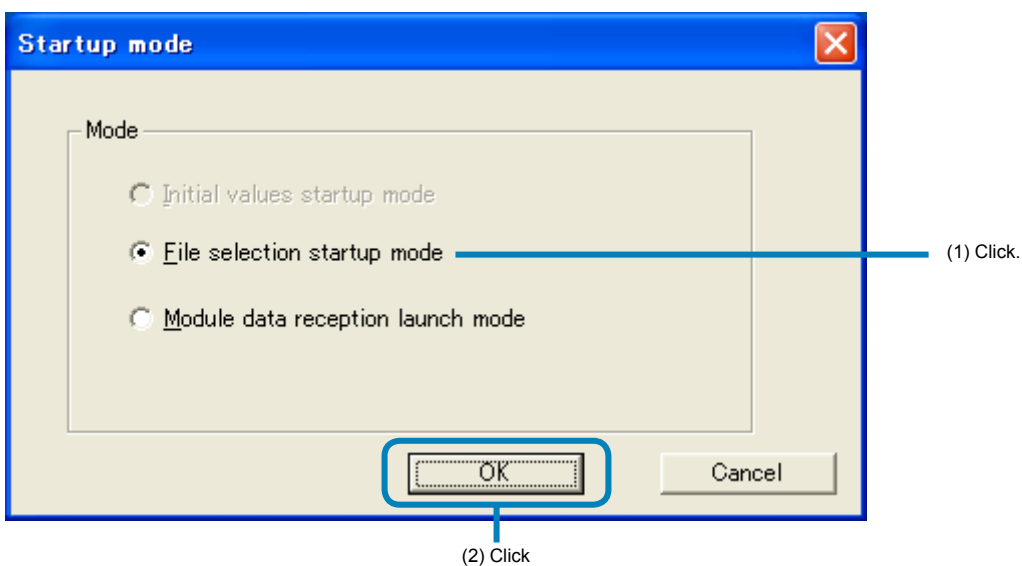

**2** On the “File selection startup mode” screen, select the file or the parameter setting stored previously, and then click [Open].

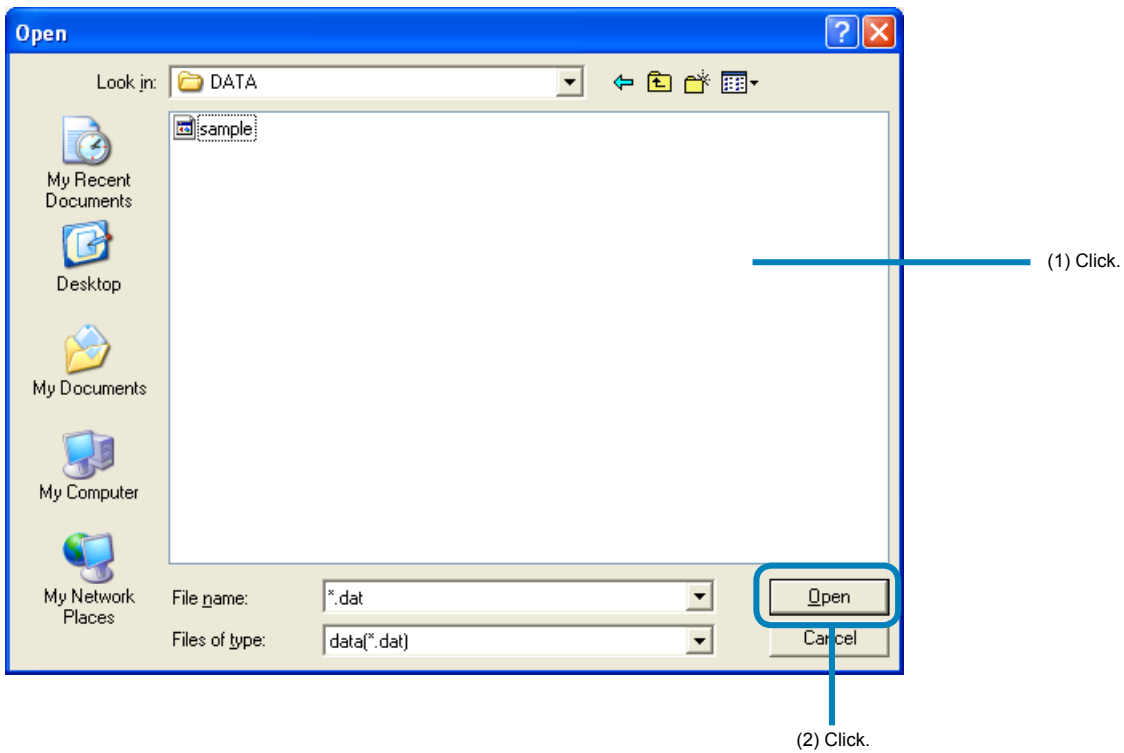

The “PUM loader-PUM parameters Support” screen appears (p.23).

---

## Selecting mode/module data reception launch mode

---

Read the parameter setting of the connected module-type temperature controllers as follows.

- 1 On the "Startup mode" screen, select "Module data reception launch mode" and then click [OK].

### The display screen of the control/event/analog module on start-up

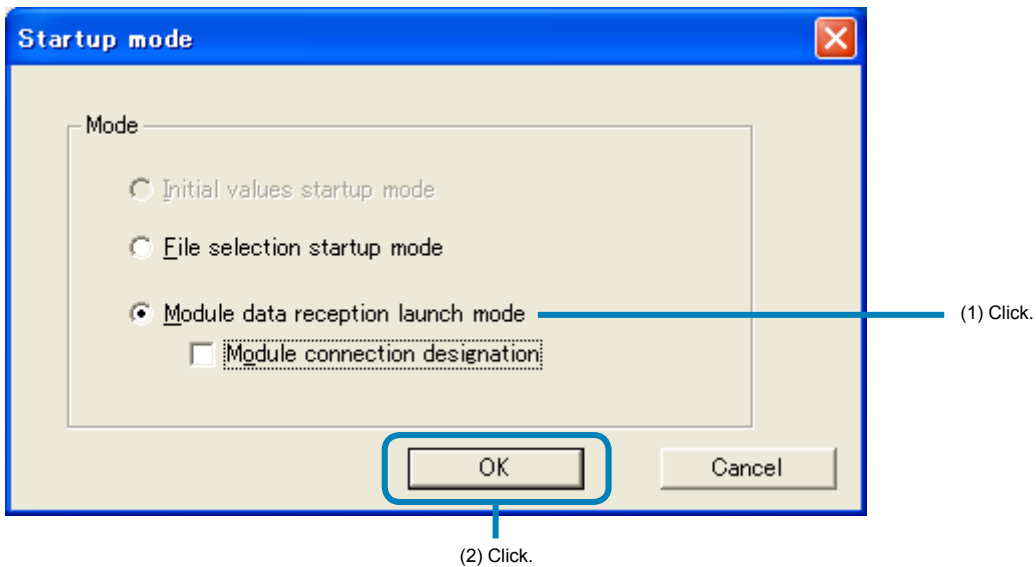

### The display screen of the enhanced communication module on start-up

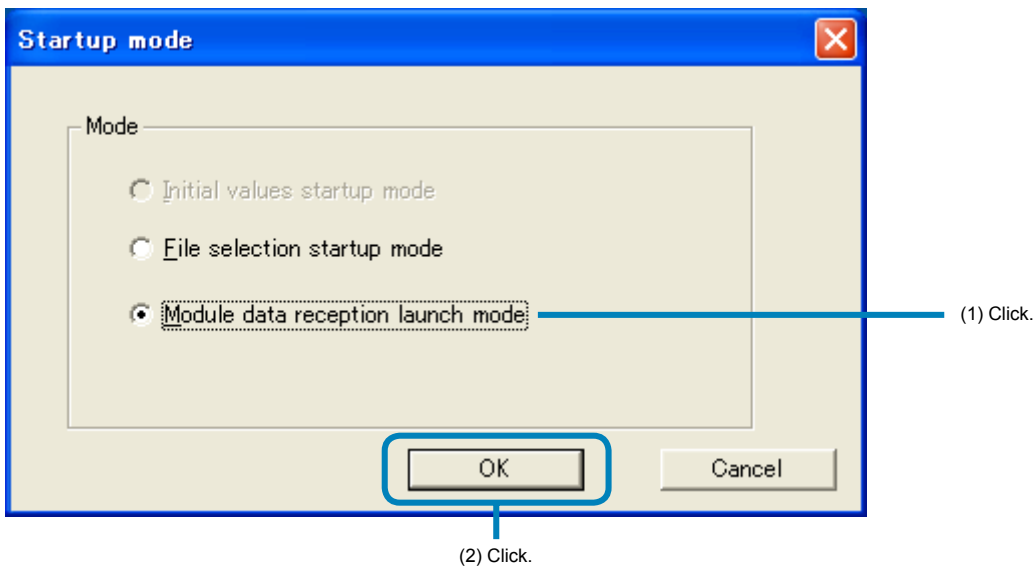

---

**2** The “PUM loader-PUM Parameters Support” screen appears (p.23).

Check the connected module-type temperature controllers automatically, and then read the set value out.

■ **To cancel reading**

Press the [Esc] key on the keyboard to cancel reading.

**Note**

- Approximately 20 seconds are required to read the parameter settings per module-type temperature controller. Do not perform other communication operations while the settings are read.
  - Do not turn off the power of the module-type temperature controller while the settings are read.
  - Do not pull out the loader connection cable while the settings are read.
-

## Reading the setting by selecting the Station No. of the module-type temperature controllers connected

This method is not available when selected the “enhanced communication module” on the “module type selection”.

- 1 Select “Module data reception launch mode” on the “Startup mode” screen, check “Module connection designation,” and click [OK].

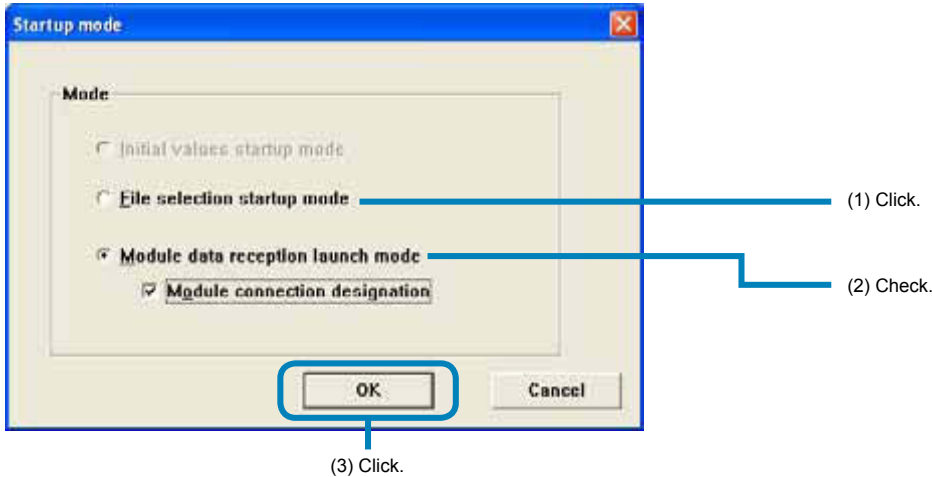

- 2 Check the St. No. of the module-type temperature controller to be read on the “Station definition” screen, and then click [OK].

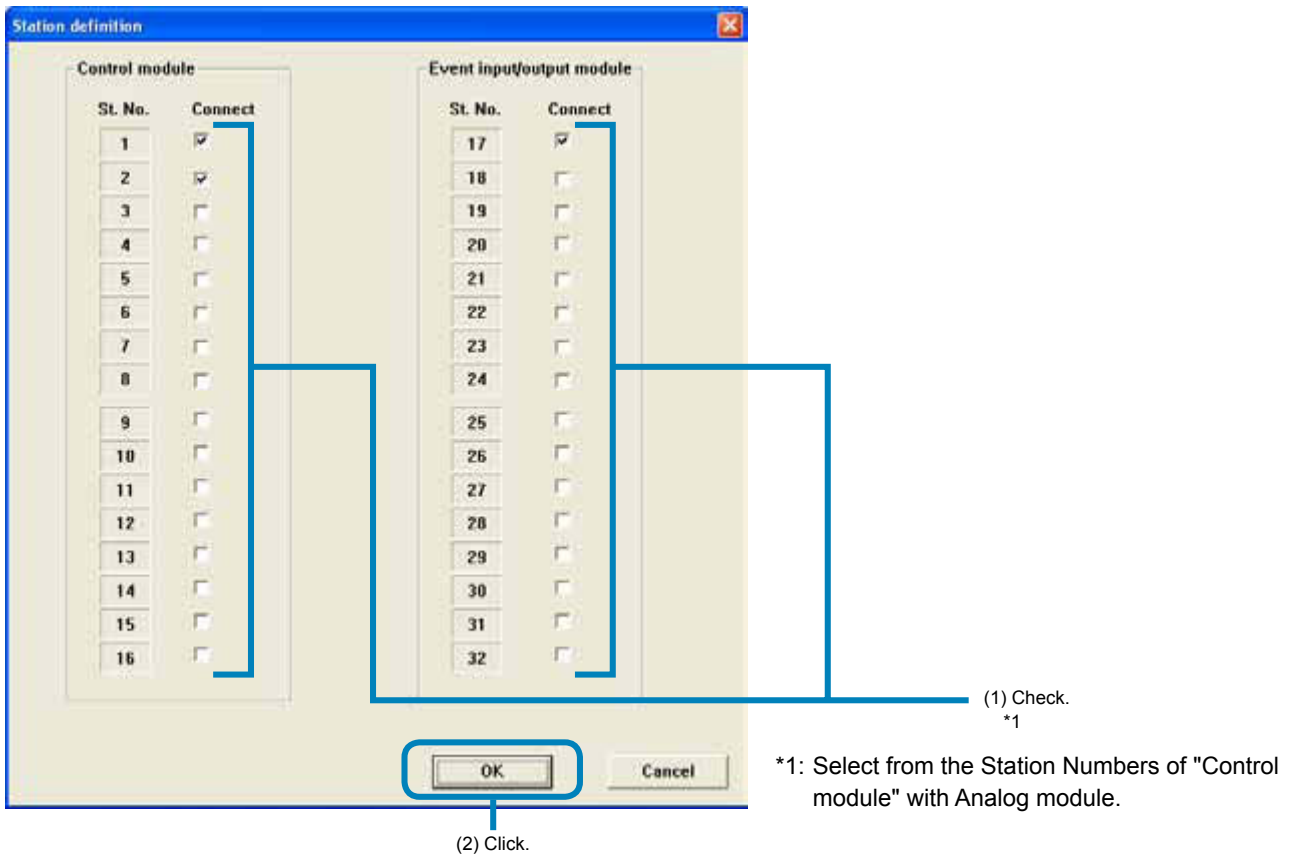

### Note

Do not check the ST No. of the controller that is not connected. Otherwise a communication error occurs. The “communication error” message does not appear in this case. (The reading from the module-type temperature controller connected is performed normally.)

**3** The “PUM loader – PUM Parameters Support” screen appears (P.23).

Read the parameter set value out from the module-type temperature controller of the St. No. that was checked in the box.

**■To cancel reading**

Press the [Esc] key on the keyboard to cancel reading.

**Note**

- Approximately 20 seconds are required to read the parameter settings per module-type temperature controller. Do not perform other communication operations while the settings are read.
- “Offline: STNo.” is displayed in (1) and a bar indicating progress status is displayed in (2) while communication is carried out. “Offline: ” is displayed in (1) and nothing is displayed in (2) when communication is not carried out.

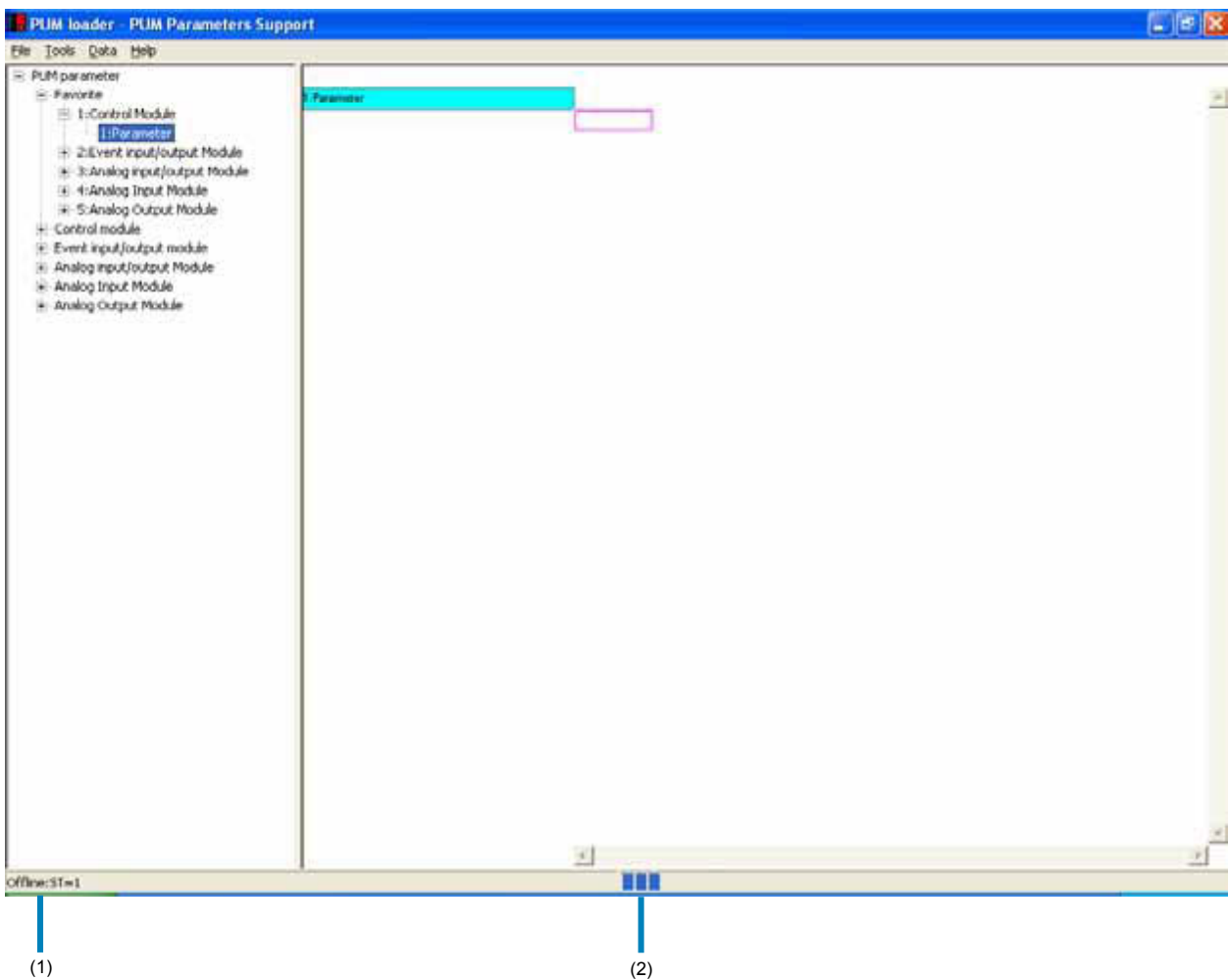

# 7 Initial setting

Perform initial setting of the PUM parameter loader as follows.

- 1 On the “PUM loader – PUM Parameters Support” screen, select “Initial setting” on the “File” menu.

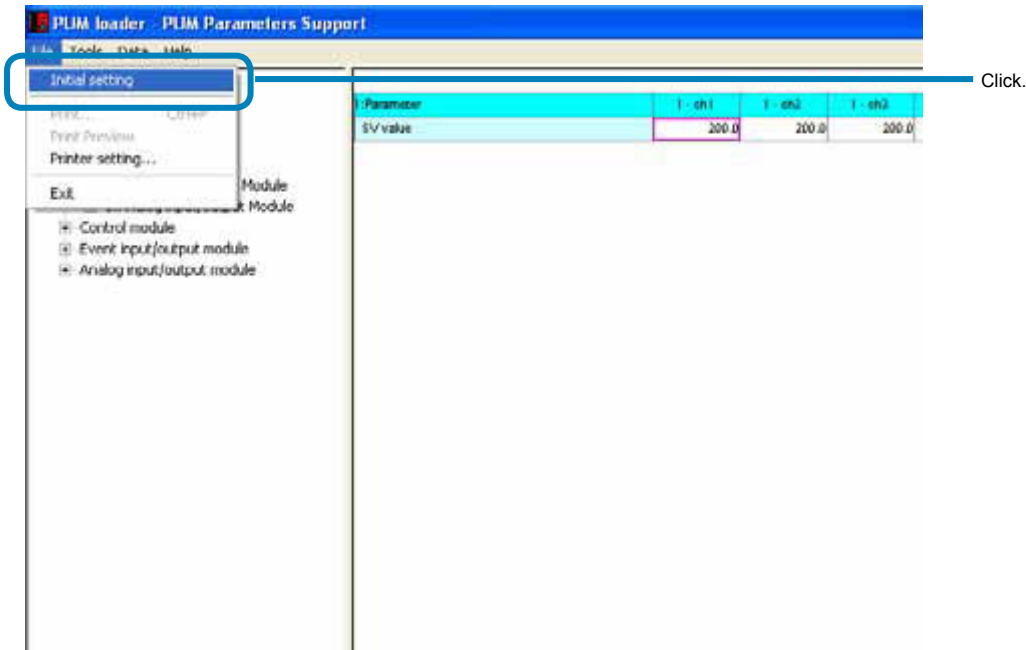

- 2 Set required items on the “Initial setting” screen, and then click [OK].

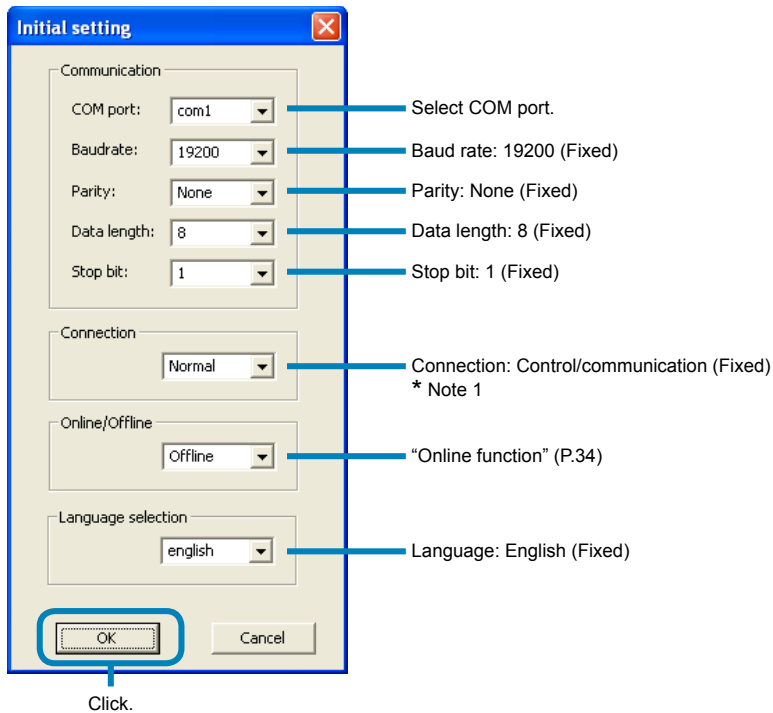

\* Note 1: Connection method is not selectable when started up with the enhanced communication module.

---

**Note**

The "Online/Offline" setting can be made only when startup is performed by selecting "Module connection designation" on the "Startup mode" screen.

The setting is always "Offline" on start-up.

---

# 8 Parameter setting

In parameter setting, frequently-used parameters can be registered in Favorite, parameter settings can be changed, state of the connected module-type temperature controllers can be checked, trend can be displayed, and parameters can be copied.

## “PUM loader – PUM Parameters Support” screen

On the “PUM loader – PUM Parameter Support” screen, parameter tree is displayed on the left, and setting can be made on the right field.

### [The display screen of the control/event/analog module on start-up]

Parameter tree is displayed.

“Station No. – (Channel)”

Operation	1 - ch1	1 - ch2	1 - ch3	1 - ch4	2 - ch1	2 - ch2	2 - ch3	2 - ch4
SV value	0.0	0.0	0.0	0.0	0.0	0.0	0.0	0.0
MV value	0.0	0.0	0.0	0.0	0.0	0.0	0.0	0.0
Manual mode switch	Auto	Auto	Auto	Auto	Auto	Auto	Auto	Auto
Run/Standby switch	Run	Run	Run	Run	Run	Run	Run	Run
Remote mode switch	Local	Local	Local	Local	Local	Local	Local	Local
Auto-tuning RUN command	Stop/End	Stop/End	Stop/End	Stop/End	Stop/End	Stop/End	Stop/End	Stop/End
Digital output latch release command	0	0	0	0	0	0	0	0
ALM1 set value 1	10.0	10.0	10.0	10.0	10.0	10.0	10.0	10.0
ALM1 set value 2	10.0	10.0	10.0	10.0	10.0	10.0	10.0	10.0
ALM2 set value 1	10.0	10.0	10.0	10.0	10.0	10.0	10.0	10.0
ALM2 set value 2	10.0	10.0	10.0	10.0	10.0	10.0	10.0	10.0
ALM3 set value 1	10.0	10.0	10.0	10.0	10.0	10.0	10.0	10.0
ALM3 set value 2	10.0	10.0	10.0	10.0	10.0	10.0	10.0	10.0
ALM4 set value 1	10.0	10.0	10.0	10.0	10.0	10.0	10.0	10.0
ALM4 set value 2	10.0	10.0	10.0	10.0	10.0	10.0	10.0	10.0
ALM5 set value 1	10.0	10.0	10.0	10.0	10.0	10.0	10.0	10.0
ALM5 set value 2	10.0	10.0	10.0	10.0	10.0	10.0	10.0	10.0

Parameters are displayed.

Set values are displayed.

**[The display screen of the enhanced communication module on start-up]**

Parameter tree is displayed.

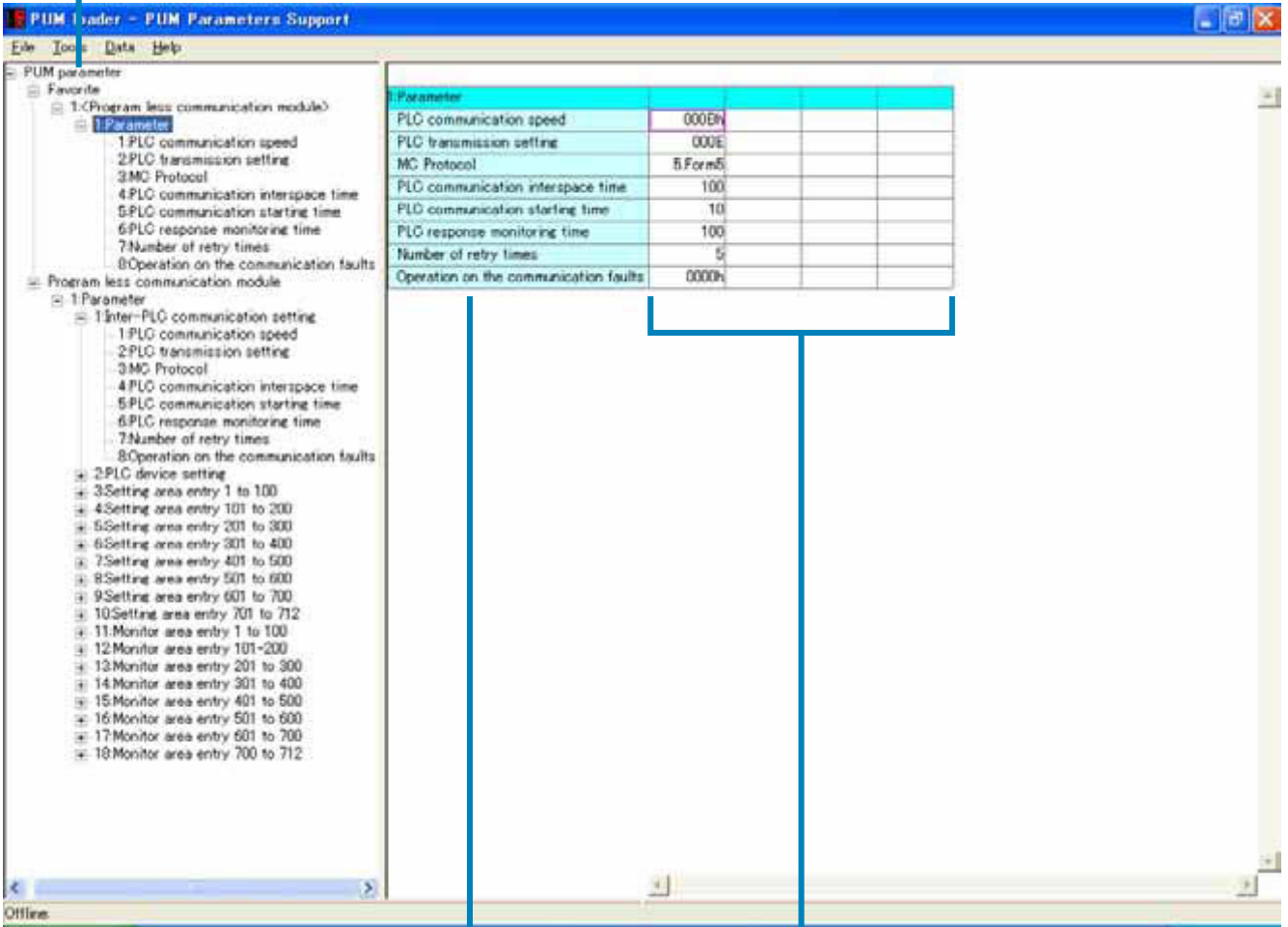

Parameters are displayed.

Set values are displayed.  
\* Blank cell cannot be set.

# Setting parameters

This section describes how to set parameters.

- 1 On the “PUM loader – PUMP Parameters Support” screen (on P.23), select the parameter group to be changed, and on the setting screen on the right, double-click the setting to be changed.

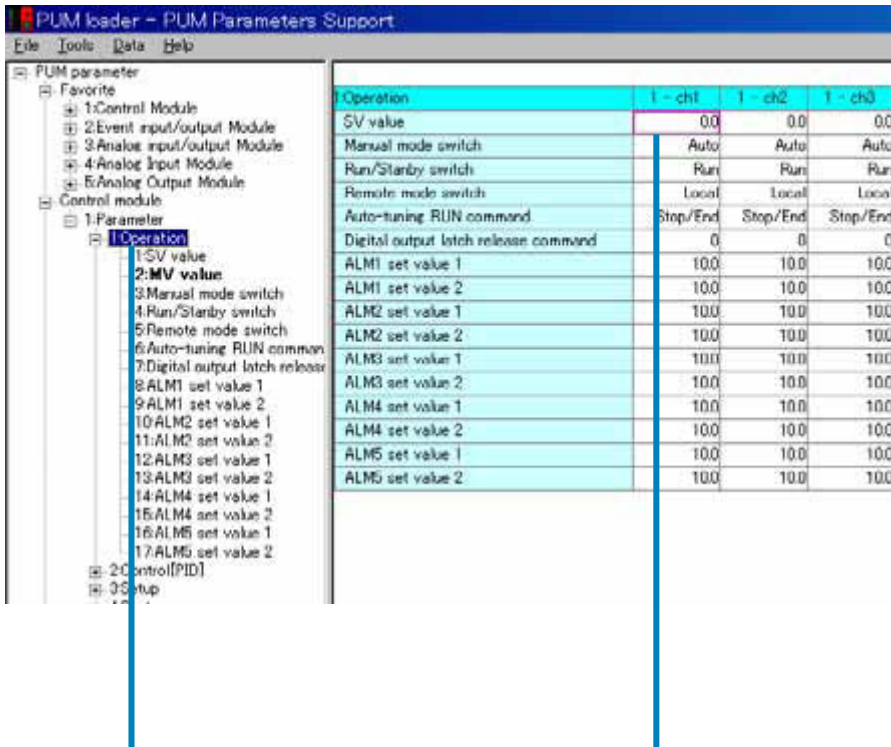

(1) Select the parameter group from the Parameter tree.

(2) Double-click the setting to be changed.

- 2 Set a desired value on the “Please set the value” window, and then click [OK].

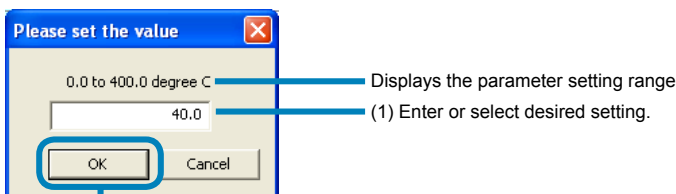

(2) Click.

## ■ To transmit the changed setting to the module-type temperature controller

See Downloading (transmission from PC to PUM) (on P.51).

---

### Note

- When entering or selecting values from the pull-down menu, be careful not to select or enter those other than the set values (such as character strings) or “No function” display other than “0: No function.”
- Do not set the same value for “PV input scale lower” and “PV input scale Upper”
- The term "Logic output" used for event module parameters represents event output.
- When PV input type, PV input scale upper/lower limit, or decimal point position is changed, review all the industrial value parameters, which are displayed in %FS unit.
- When the parameter display is scrolled, parameters of a different group may be displayed. In this case, display a different group first, and then display the desired group.
- The setting range display may exceed the value that can actually be set.
- Do not directly enter numeric values for the parameters for which pull-down menu is displayed. (The values that do not fall within the setting range may be set.)
- Some values banned setting are included in the setting range displayed in the enhanced communication module. Refer to the detailed parameter manual in the relevant parameters (p.32) about the values banned setting.

---

### Point

- Press the [Enter] key on the keyboard while the setting to be changed is selected, and the setting entry or selection screen is displayed. If the [F5] key on the keyboard is pressed, the focus is switched between the parameter tree screen (on the left side) and the setting screen (on the right side).
- The settings that have been changed are displayed in red. The red display is kept valid until they are uploaded.
- <SV limit value>  
The SV value is limited and automatically changed according to the change of SV limit.
- <Automatic industrial value conversion>  
The parameters displayed in industrial values are automatically converted into values within the setting range in accordance with the change of PV input type, PV scale, and decimal point position.
- <Automatic alarm setting conversion>  
The alarm settings are automatically converted into values within the setting range in accordance with the DO output event type setting.

## Favorite

Frequently-used parameters can be set in “Favorite” in the parameter tree screen on the left side. Up to 200 parameters per module can be registered.

The screenshot shows the 'PUM loader - PUM Parameters Support' application. On the left is a tree view of parameters. The 'Favorite' section is expanded, showing parameters for the Control Module, Analogue Input/Output Module, and Control module. On the right is a table of parameters with columns for the parameter name and three channels (1 - ch1, 1 - ch2, 1 - ch3). The table lists parameters such as Proportional band[P], Integration time[I], Derivation time[D], SV value, and MV value.

Parameter	1 - ch1	1 - ch2	1 - ch3
Proportional band[P]	5.0	5.0	5.0
Integration time[I]	240	240	240
Derivation time[D]	60.0	60.0	60.0
SV value	0.0	0.0	0.0
MV value	0.0	0.0	0.0

Displays parameters set in “Favorite.”

## Registering in “Favorite”

- 1 On the parameter tree of the “PUM loader – PUM Parameters Support” screen (on P.23), right-click the parameter you want to register in “Favorite” and then click “Favorite Add/Delete.”

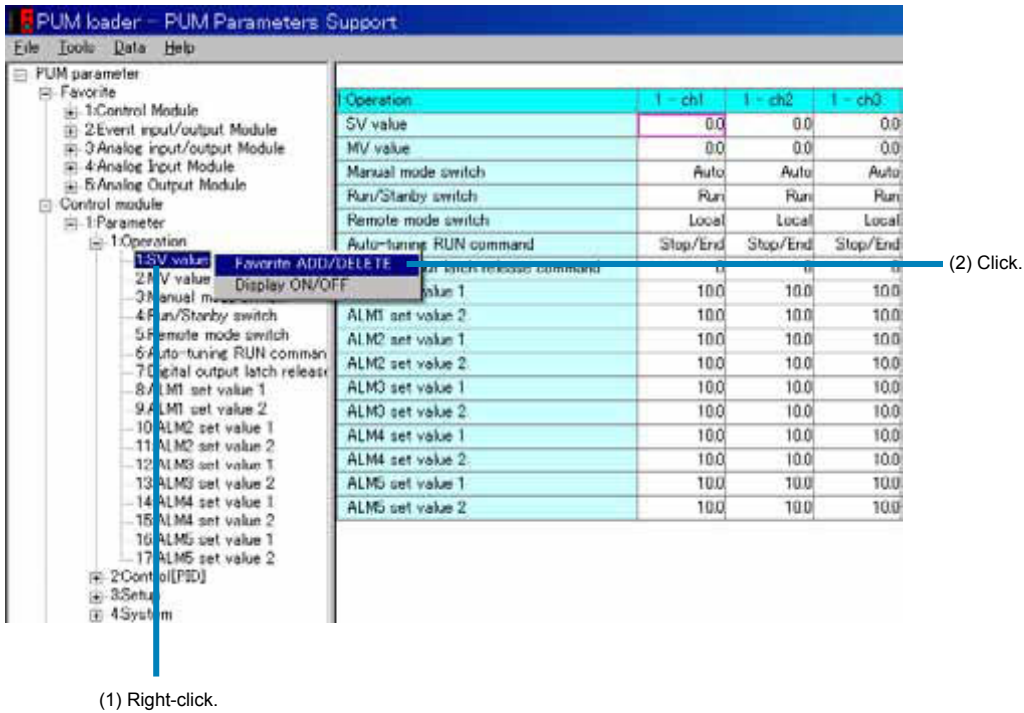

### Point

Press the [F2] key on the keyboard while a parameter is selected on the parameter tree on the left side, and the parameter can be registered in Favorite.

## Deleting the registration in “Favorite”

- 1 Right-click a parameter within the “Favorite” tree on the “PUM loader – PUM Parameters Support” screen (on P.23), and then click “Favorite Add/Delete.”

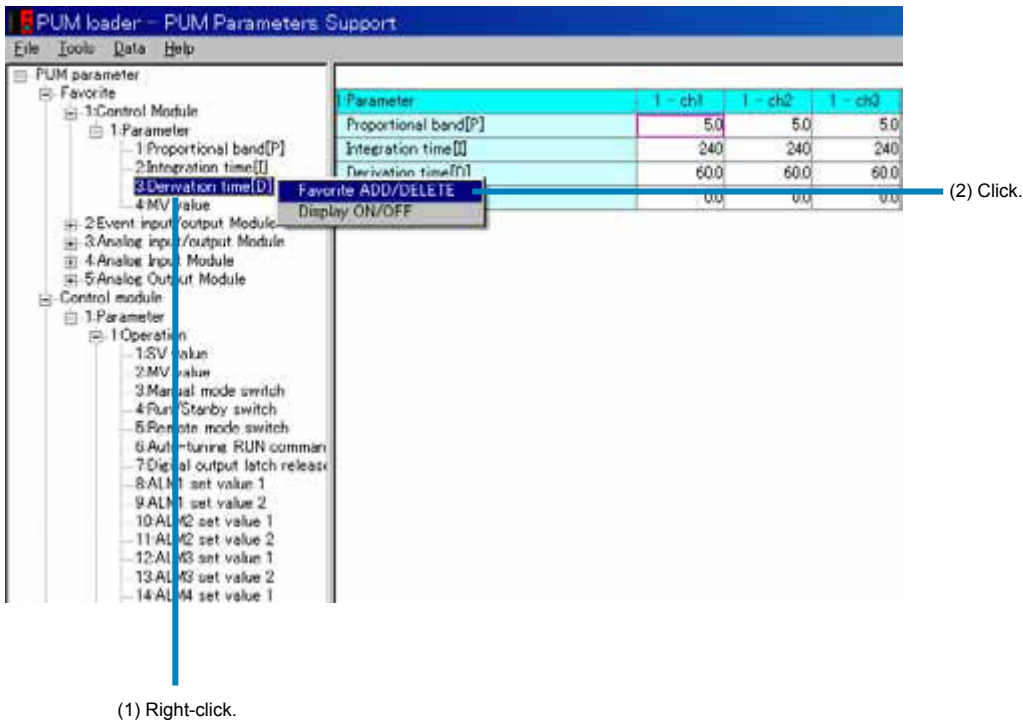

### Point

Press the [F2] key on the keyboard while a parameter is selected on the parameter tree screen on the left side, and the parameter can be deleted from Favorite.

# Switching between display ON and OFF

Parameter display on the setting screen on the right side can be changed between ON and OFF.

The screenshot shows the 'PUM loader - PUM Parameters Support' window. On the left is a tree view of parameters, and on the right is a table of values for three channels (1-ch1, 1-ch2, 1-ch3). The '1-Operation' parameter is selected in the tree view. The table shows various parameters and their values for each channel. Some values are 'OFF', and some are '10.0'.

Operation	1 - ch1	1 - ch2	1 - ch3
SV value	0.0	0.0	0.0
Manual mode switch	Auto	Auto	Auto
Run/Standby switch	Run	Run	Run
Remote mode switch	Local	Local	Local
Auto-tuning RUN command	Stop/End	Stop/End	Stop/End
Digital output latch release command	0	0	0
ALM1 set value 1	10.0	10.0	10.0
ALM1 set value 2	10.0	10.0	10.0
ALM2 set value 1	10.0	10.0	10.0
ALM2 set value 2	10.0	10.0	10.0
ALM3 set value 1	10.0	10.0	10.0
ALM3 set value 2	10.0	10.0	10.0
ALM4 set value 1	10.0	10.0	10.0
ALM4 set value 2	10.0	10.0	10.0
ALM5 set value 1	10.0	10.0	10.0
ALM5 set value 2	10.0	10.0	10.0

Parameters set as "OFF" are not displayed on the setting screen on the right side.

Parameters set as "OFF" are displayed in boldface type.

## Switching between display ON and OFF

- 1 Right-click the parameter to be or not to be displayed on the parameter tree screen (on the left side) of the “PUM loader – PUM Parameters Support” screen (on P.23), and click “Display ON/OFF.”

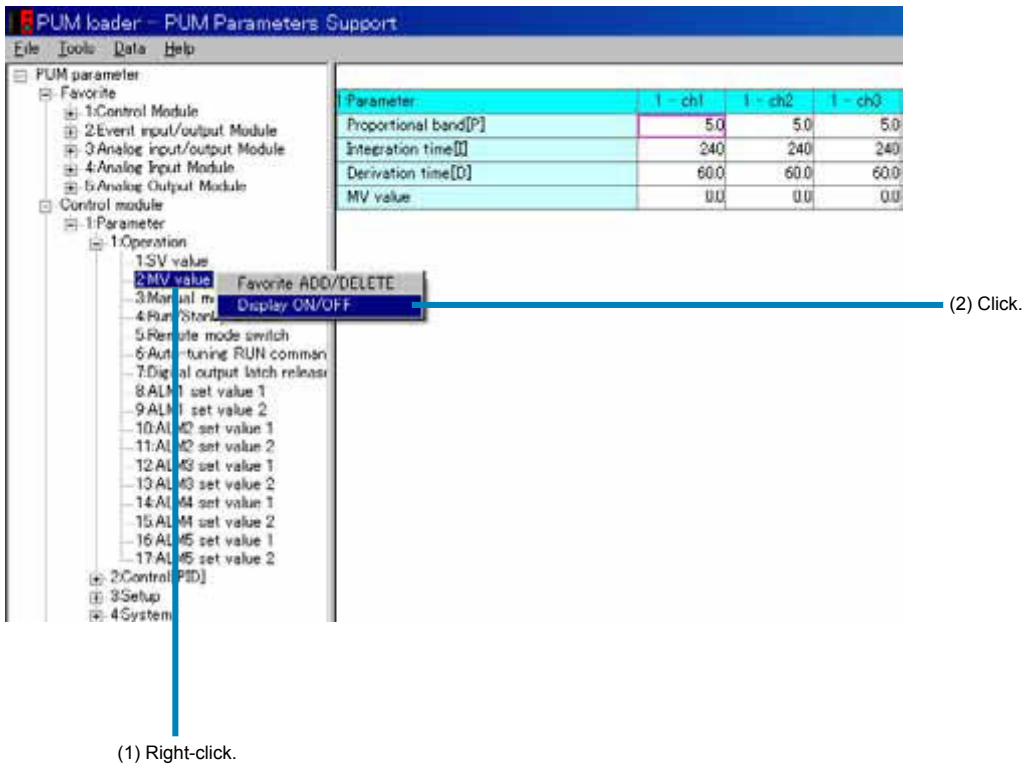

### Point

- You can also press the [F4] key on the keyboard while the parameter is selected on the parameter tree screen (on the left side) to switch between ON and OFF.
- You can also double-click the parameter on the parameter tree screen (on the left side) to switch between ON and OFF.

## Relevant parameters

Detailed description of the selected parameters can be displayed. Detailed display/settings of related parameters can also be made.

- 1 Select a parameter from the parameter tree screen on the left side of the “PUM loader – PUM Parameters Support” screen (on P.23), and then right-click the setting that displays a related parameter on the setting screen (on the right side).

Operation	1 - ch1	1 - ch2	1 - ch3
SV value	0.0	0.0	0.0
Manual mode switch	Auto	Auto	Auto
Run/Standby switch	Run	Run	Run
Remote mode switch	Local	Local	Local
Auto-tuning RUN command	Stop	Stop/End	Stop/End
Digital output latch release command	0	0	0
ALM1 set value 1	10.0	10.0	10.0
ALM1 set value 2	10.0	10.0	10.0
ALM2 set value 1	10.0	10.0	10.0
ALM2 set value 2	10.0	10.0	10.0
ALM3 set value 1	10.0	10.0	10.0
ALM3 set value 2	10.0	10.0	10.0
ALM4 set value 1	10.0	10.0	10.0
ALM4 set value 2	10.0	10.0	10.0
ALM5 set value 1	10.0	10.0	10.0
ALM5 set value 2	10.0	10.0	10.0

(1) Select a parameter from the tree.

(2) Right-click the setting that displays a related parameter, or press the [F1] key on the keyboard.

2 Check the related parameter on the “Relevant parameters” screen.

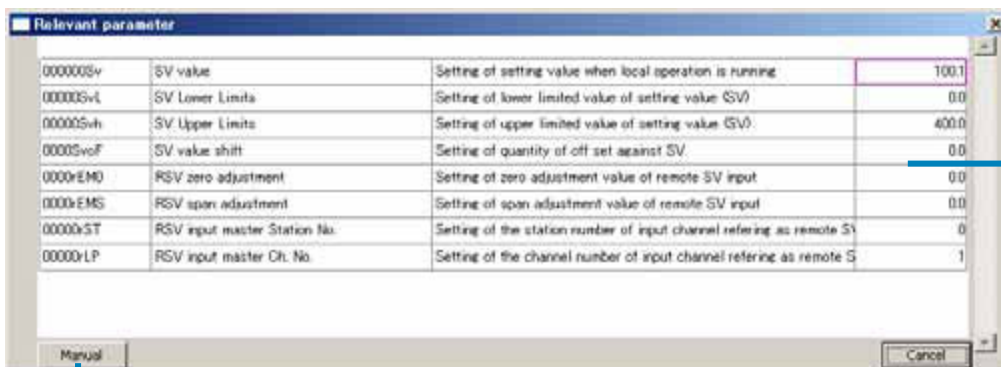

Displays related parameters. Setting change can also be made.

Click to display detailed manual of the parameter.

■ To display detailed manual of the parameter

Click [Manual], and detailed manual of the parameter is displayed.

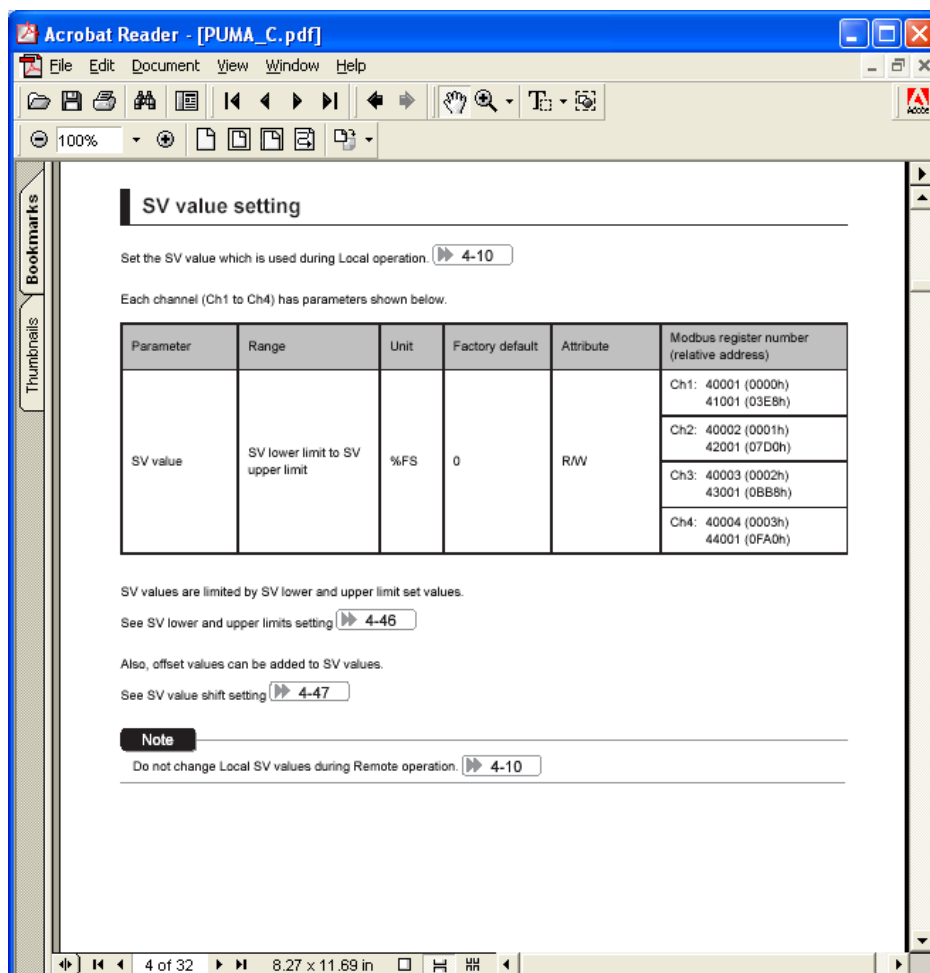

## Online function

As soon as the parameter is changed, the change can be written into the module-type temperature controller.

- 1 Select "Initial setting" on the "File" menu of the "PUM loader – PUMP Parameters Support" screen (on P.23).

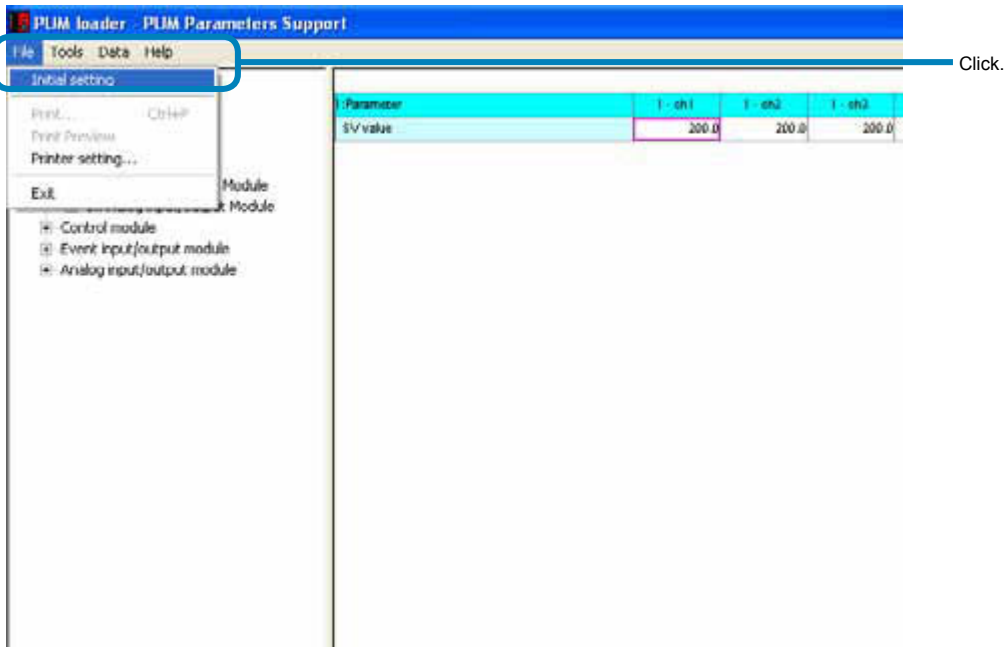

- 2 Select "Online" on the "Initial setting" screen, and then click [OK].

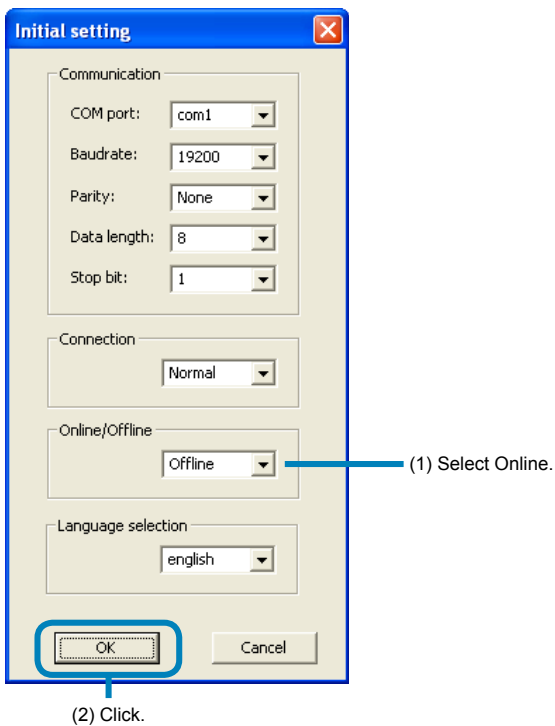

---

**Note**

- The "Online/Offline" setting can be made only when startup is performed by selecting "Module data reception launch mode" in "Startup mode" (P.17).
  - If a parameter that affects other parameters is changed online, all the parameters of the module-type temperature controller having the changed parameter are read. Reading takes approximately 20 seconds per module-type temperature controller.
  - If a parameter that changes its value when processing is exited such as auto tuning start command, reading is continued until the value reaches "0."
  - If "Offline" is selected in initial setting, do not set values for the following parameters other than those shown.  
"Auto - tuning RUN command" = Stop/End  
"Digital output latch release command" = OFF  
"Reset main unit" = None
  - The setting is always "Offline" on start-up.
-

# Module composition

The composition of the connected module-type temperature controllers can be checked.

- 1 Select "Module composition" from the "Tool" menu of the "PUMP loader – PUM Parameters Support" screen (on P.23).

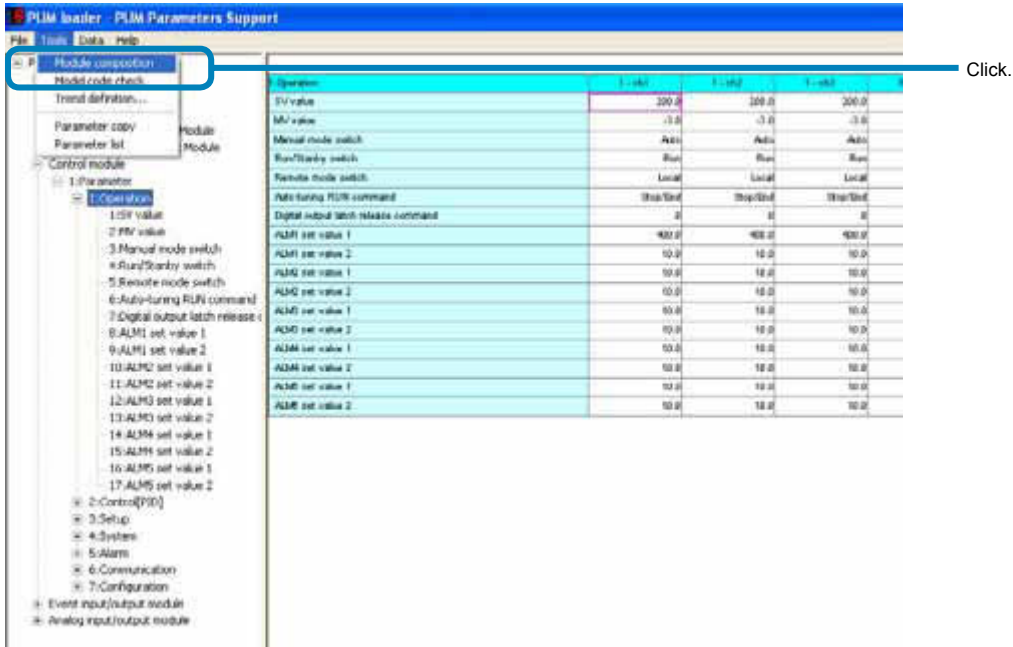

- 2 Check the composition of the module-type temperature controller on the "Module composition" screen.

## [Display screen of the control/event/analog module on start-up]

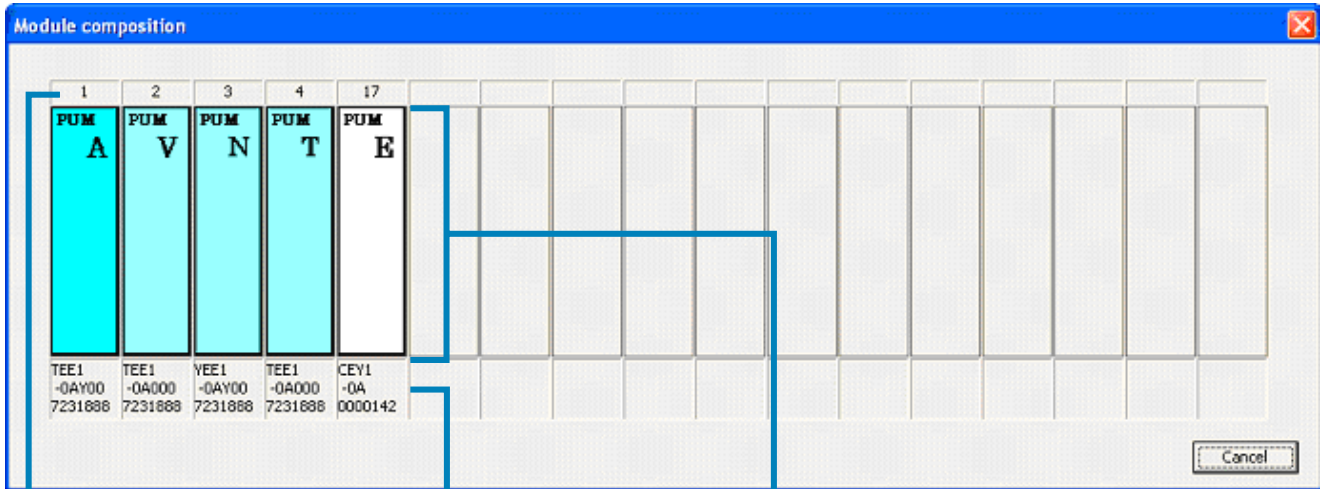

Displays Station No.

Displays model code/serial code.

Displays the module-type temperature controller connected.

## [Display screen of the enhanced communication module on start-up]

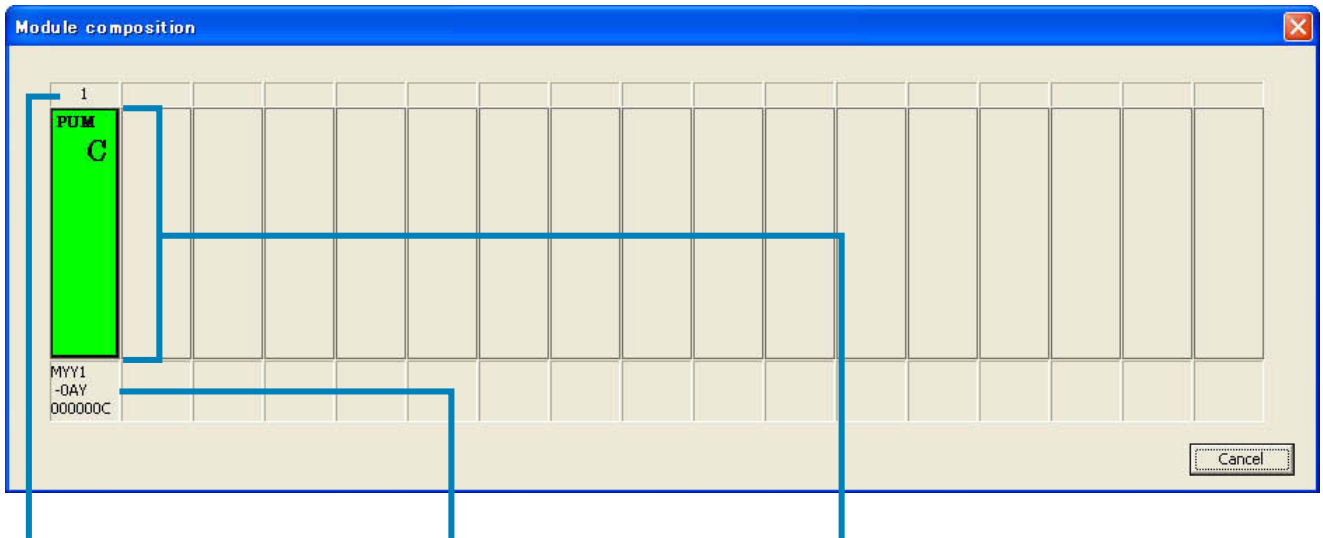

It displays St. No. for enhanced communication. (\*Note that this is different from the St. No. of the loader communication port)

It displays model code/serial code.

It displays the connected module-type temperature controller.

### Note

Error is displayed if the module-type temperature controller is not connected properly.

## [Error display]

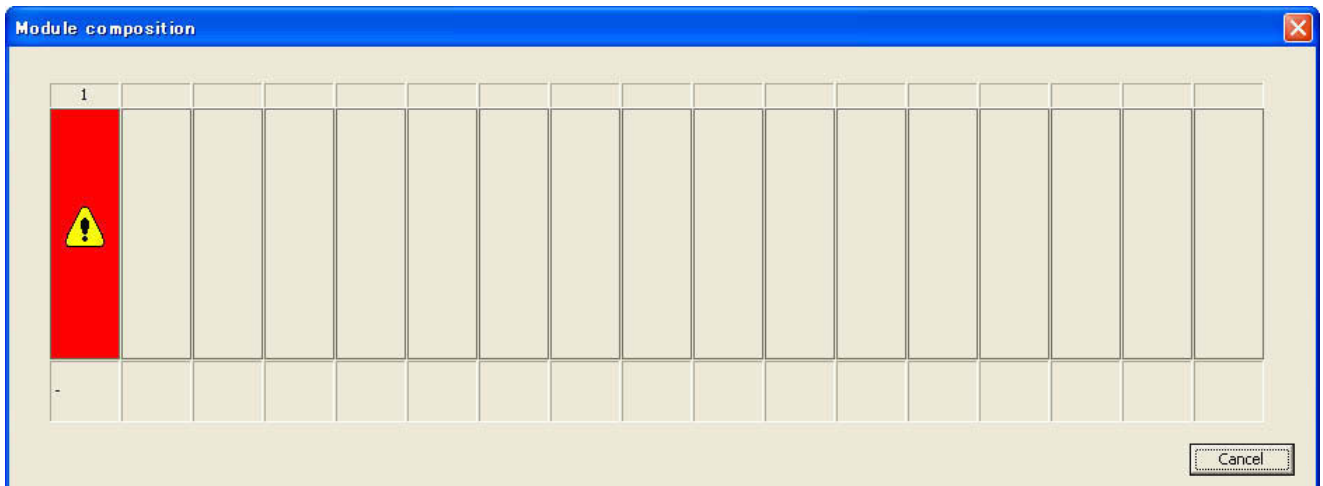

## Checking the type code

The type code of the module-type temperature controller currently edited can be checked.

- 1 Select "Model composition" from the "Tool" menu of the "PUM loader – PUM Parameters Support" screen.

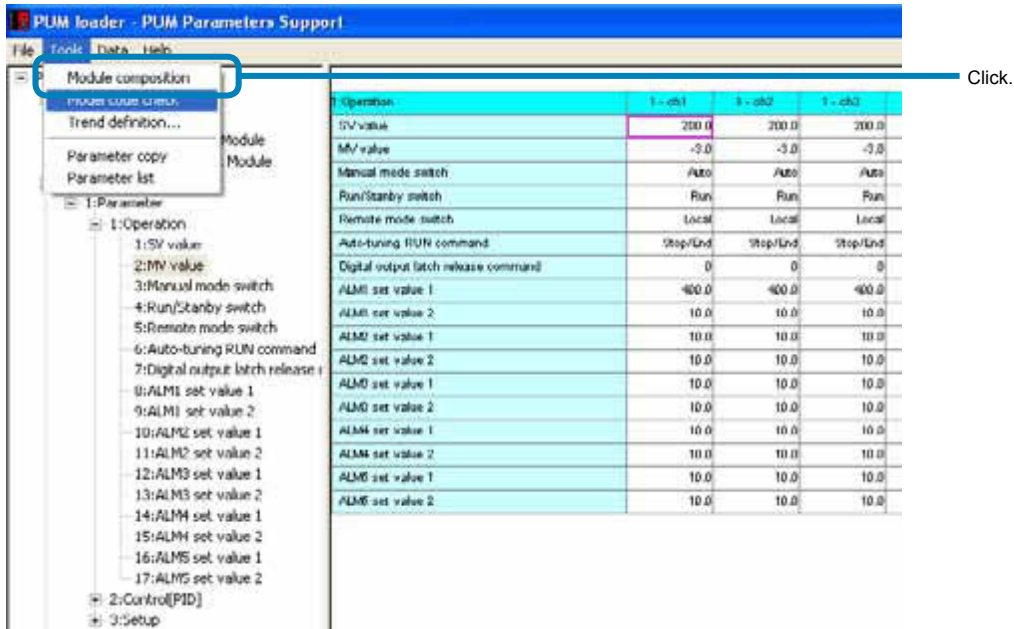

- 2 Select a desired model code on the "Display model code" screen, and then click [OK].

### [Display screen of the control/event/analog module on start-up]

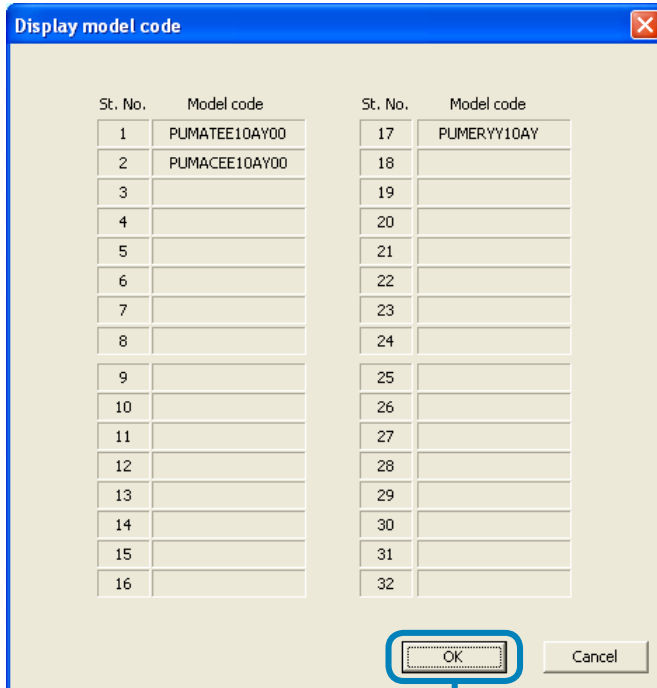

---

**[Display screen of the enhanced communication module on start-up]**

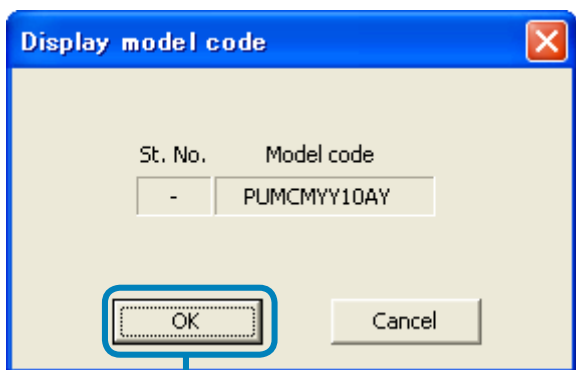

Click.

# Displaying trend

Data trend can be displayed. Pens can be defined for up to 10 groups, with 8 pens regarded as one group.  
 •This method is not available when selected the “enhanced communication module” on the “module type selection”.

1 Select “Trend definition” from the “Tool” menu of the “PUM loader – PUM Parameters Support” screen (on P.23).

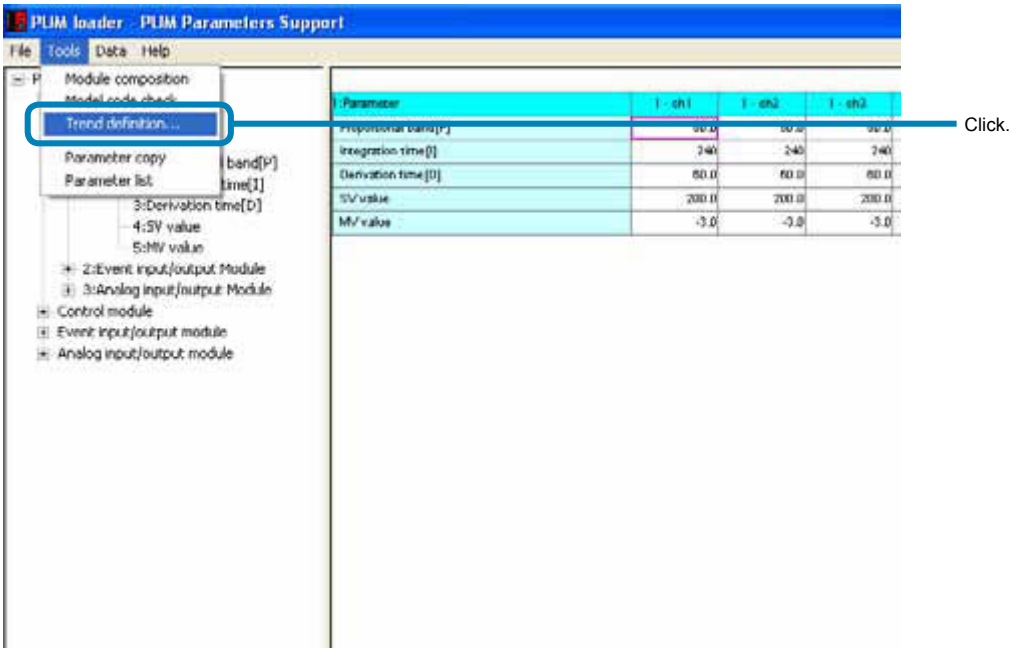

2 Set required items on the “Trend selection” screen, and then click “Trend Disp.”

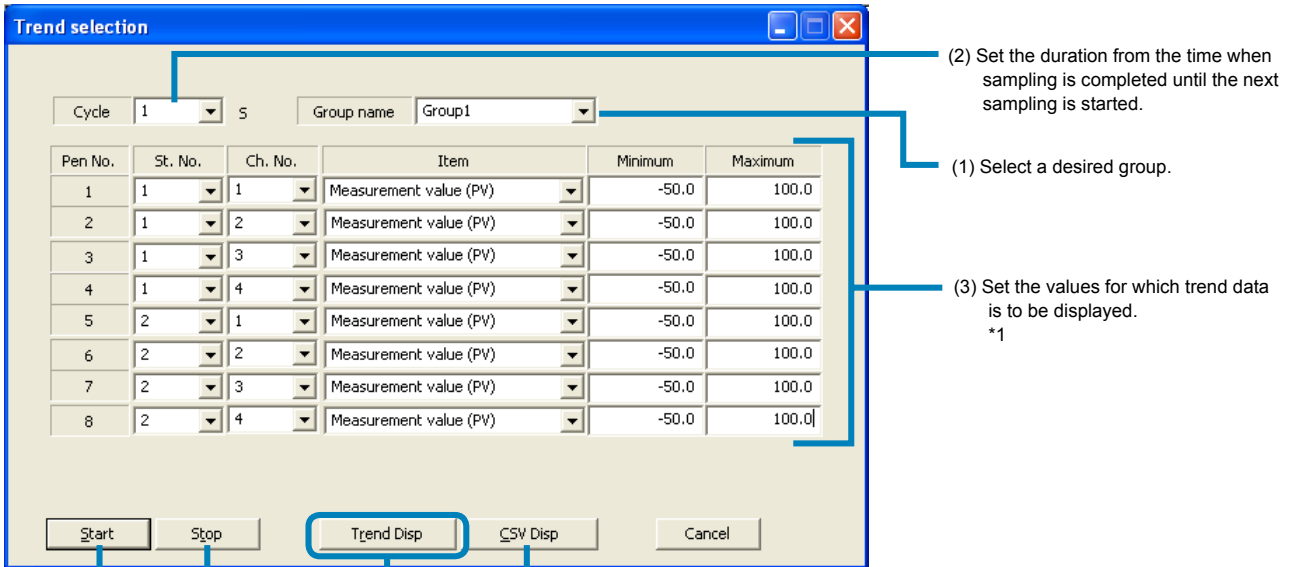

- (2) Set the duration from the time when sampling is completed until the next sampling is started.
- (1) Select a desired group.
- (3) Set the values for which trend data is to be displayed.  
\*1
- (4) Starts collecting the trend data.
- (5) Click.
- (6) Stops collecting the trend data.
- (7) Displays the trend data in CSV format.

\*1: When you select the St. No from the analog module, do not select "Set value (SV)", "Manipulating value (MV1)", or "Manipulating value (MV2)".

**3** Check the trend display on the “TrendDisplay – Trend” screen.

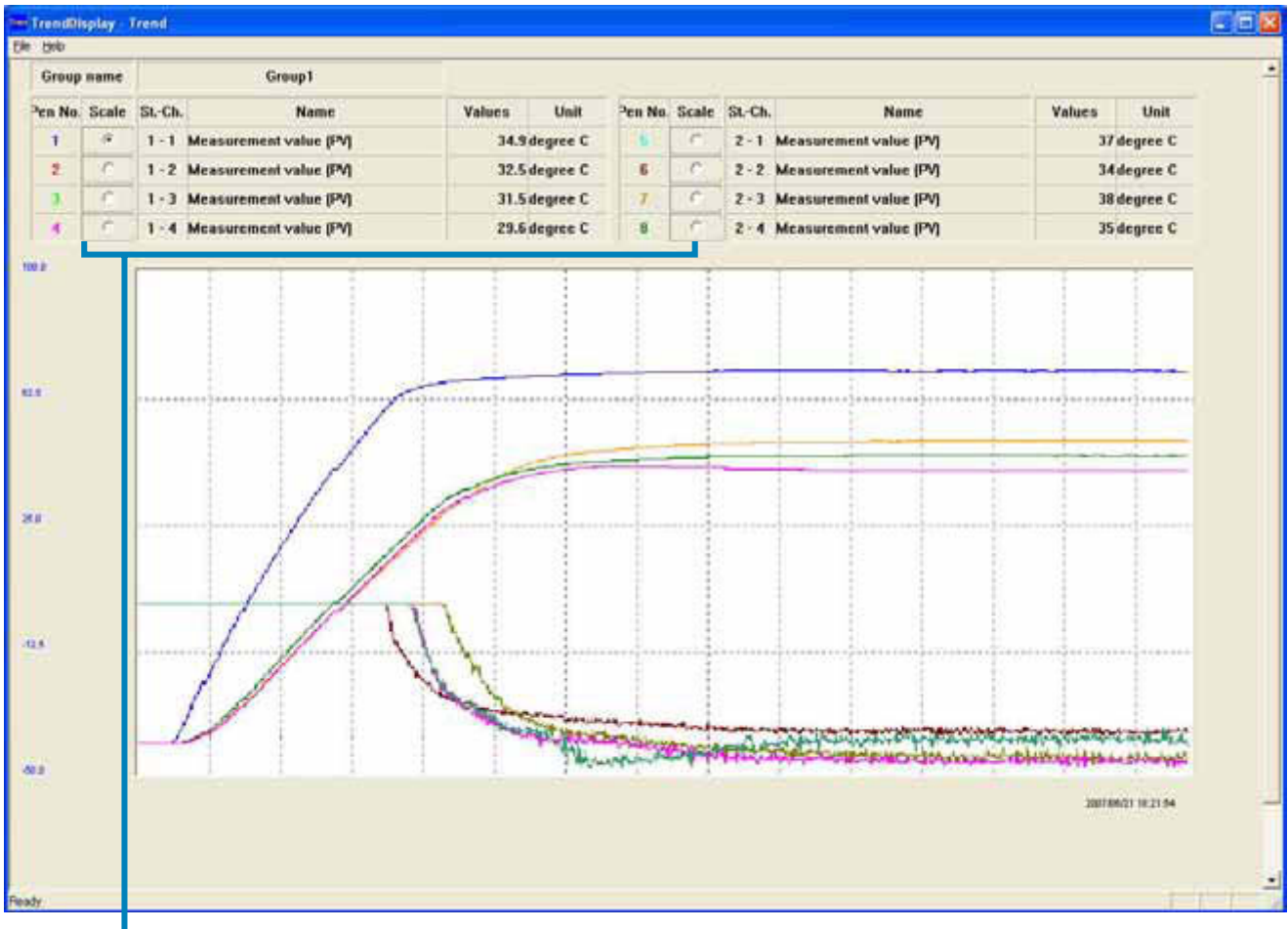

Select a pen for which scale is to be displayed.

**Note**

- Save the trend data, if required, in a CSV file by giving a name to it.
- If the trend data is displayed in a CSV file, the CSV file previously displayed is overwritten.
- If the displayed CSV file is saved, the time display becomes “00” (fraction omitted).
- If sec. display is required, select “time” for display format in Excel cell format setting, change it into desired display format, and then save the data.
- The first data at the start of trend display may differ from the actual value.
- Do not press the “Start trend” button on the trend select screen while the trend is being displayed. Otherwise the trend is displayed overlapped.
- The final data may not be displayed when the trend display is stopped. Check the data in CSV format in this case.
- When you select the St. No from the analog module, do not select "Set value (SV)", "Manipulating value (MV1)", or "Manipulating value (MV2)".

# Copying parameters

Parameter settings can be copied between channels or stations.

•This method is not available when selected the “enhanced communication module” on the “module type selection”.

## Copying between channels

1 Select “Parameter copy” from the “Tool” menu of the “PUM loader – PUM Parameters Support” screen (on P.23).

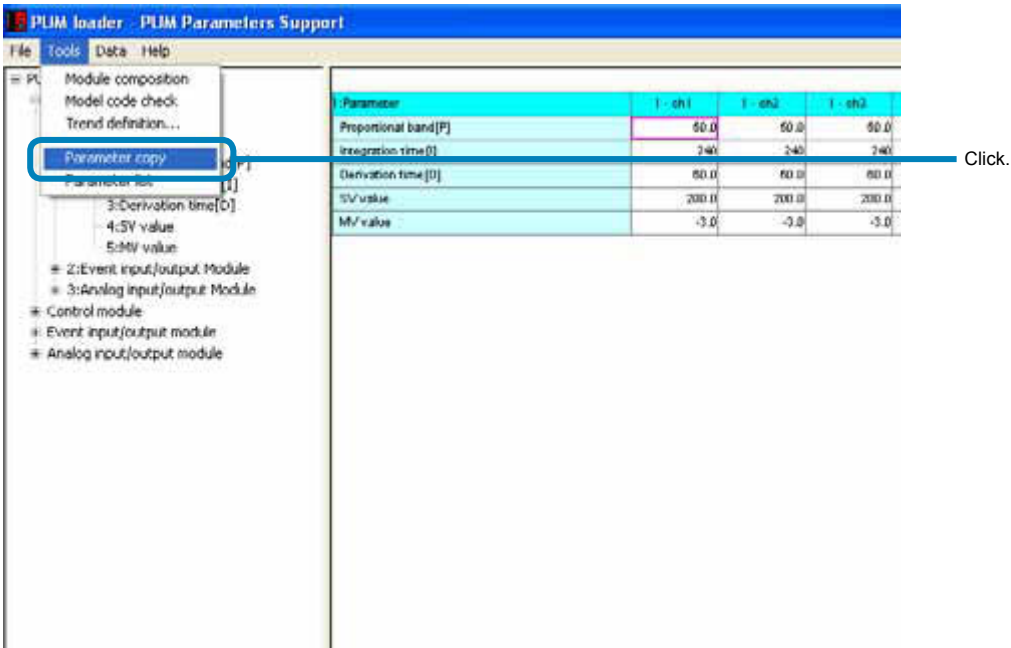

2 Click the “Ch. Copy” tab on the “Parameter copy” screen.

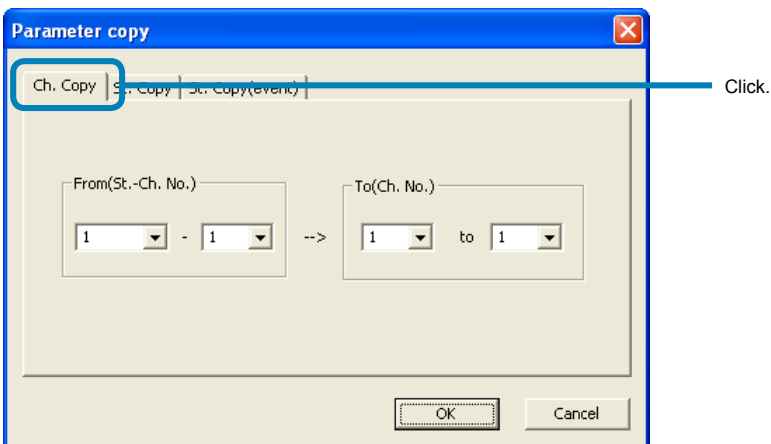

3 Select the St-Ch No. from which the parameter is to be copied and that to which it is written, and then click [OK].

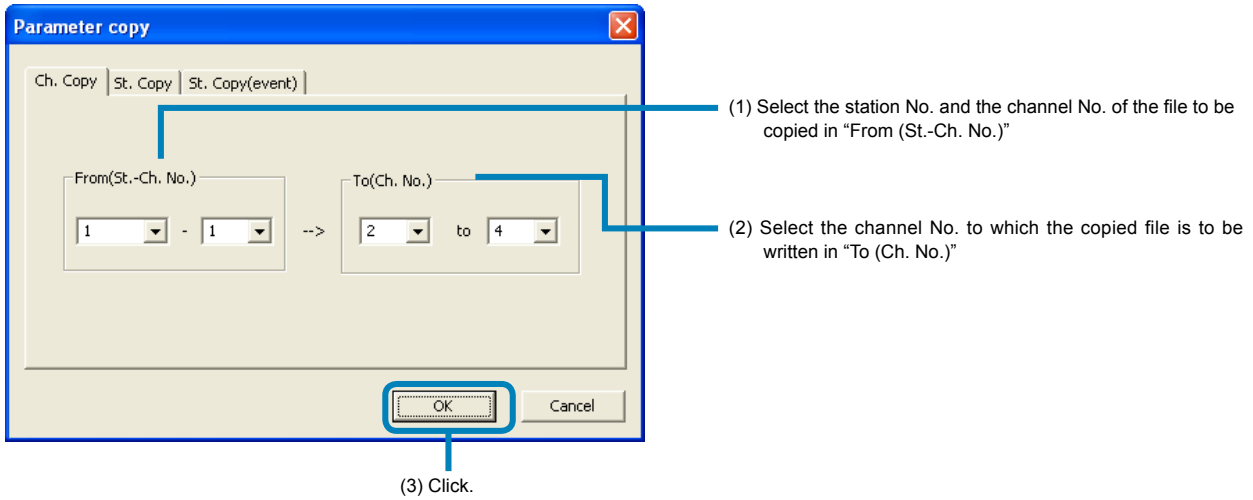

4 Click [OK] on the "PUM loader" window.



■To cancel parameter copying

Click [Cancel].

Point

In Ch. copy, the data is copied only within the station specified in "From (St.-Ch. No.)".

Note

- Make sure that the channel No. on the right side becomes smaller than that of the left side when specifying the channel to which the parameter is to be written.
- Copied parameters are not written into the module-type temperature controller online.
- When "Ch. copy" in parameter copy function is used, do not specify the No. of the station that does not exist. Otherwise an erroneous value is copied.

## Copying between stations

1 Select "Parameter copy (C)" from the "Tool (T)" menu of the "PUM loader – PUM Parameters Support" screen (on P.23).

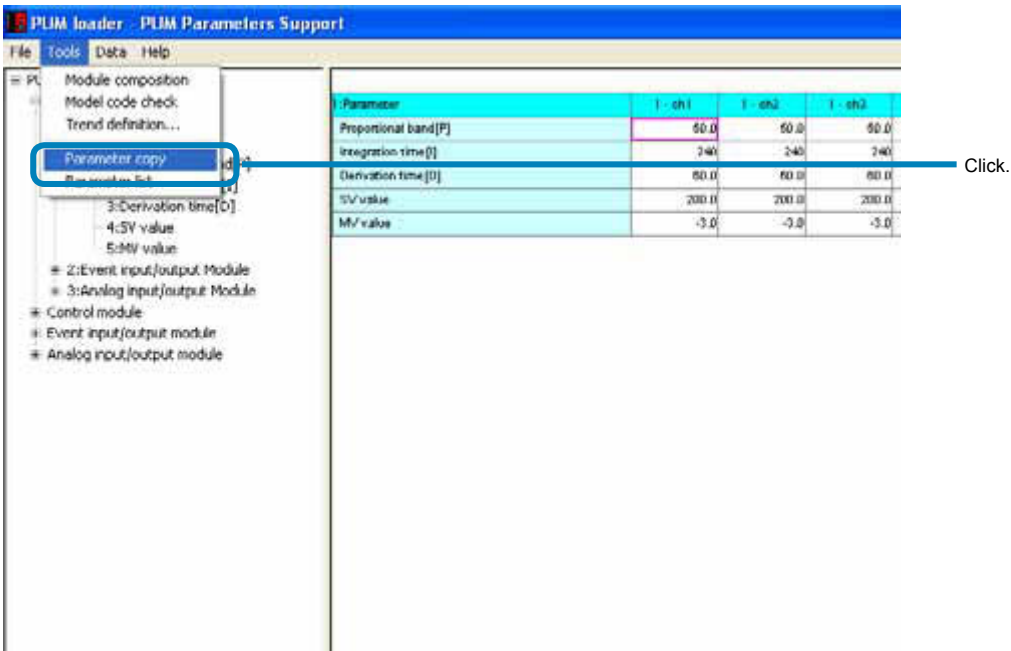

2 Click the "St. copy" tab on the "Parameter copy" screen.

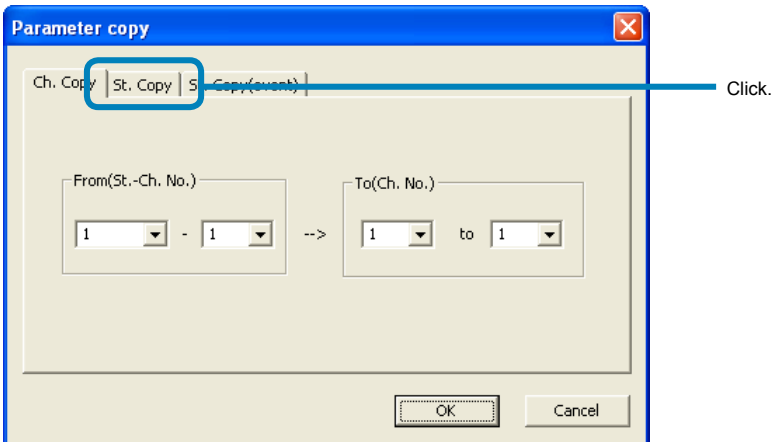

### ■ To copy event module parameters between stations

Click the "St. copy (Event)" tab.

- 3 Select the St-Ch No. from which the parameter is to be copied and that to which it is written, and then click [OK].

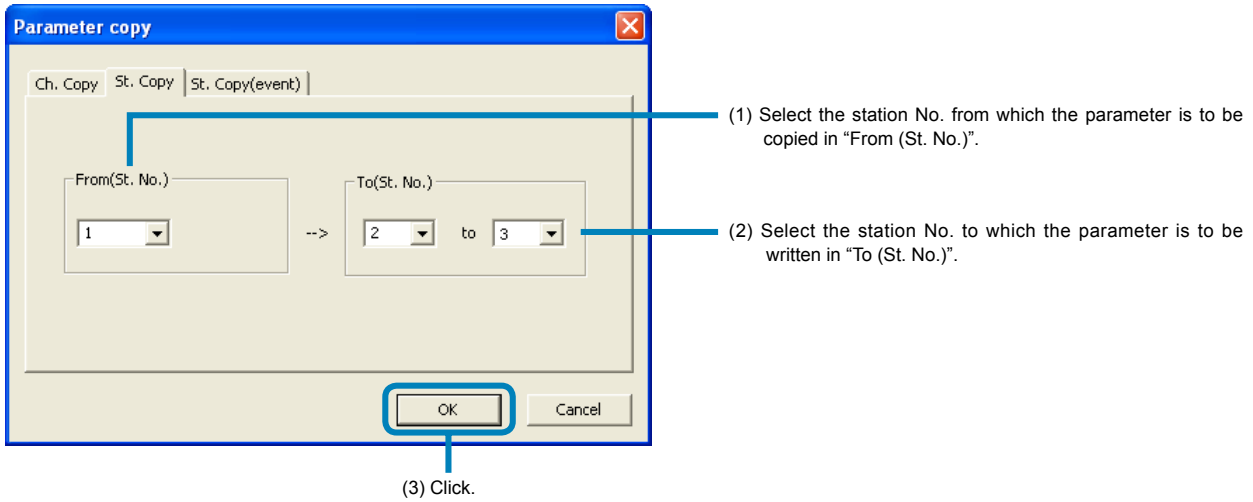

- 4 Click [OK] on the "PUM loader" screen.



■ **To cancel the parameter copy**

Click [Cancel].

**Point**

Follow the same procedure for copying parameters between stations (Event).

**Note**

- Be sure not to specify station No. that has not been defined. Otherwise an erroneous value may be written in the parameter.
- Make sure that the station No. of the right side becomes smaller than that of the left side when specifying the station to which the parameter is to be written.
- Copied parameters are not written into the module-type temperature controller online.
- You cannot inter-station copy on the other type modules.

# Parameter list

Parameter setting can be printed or displayed in CSV file format for each module-type temperature controller.

- 1 Select "Parameter list" from the "Tool" menu of the "PUM loader – PUM Parameters Support" screen (on P.23).

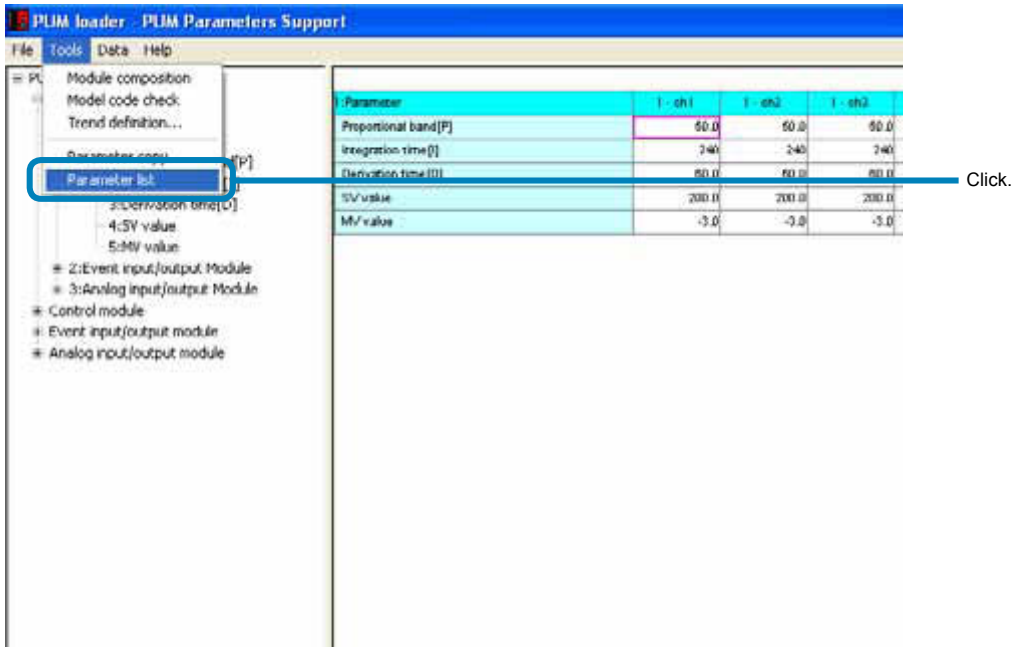

- 2 Set necessary items on the "Parameter list" screen, and then click "Print" or "CSV Disp."

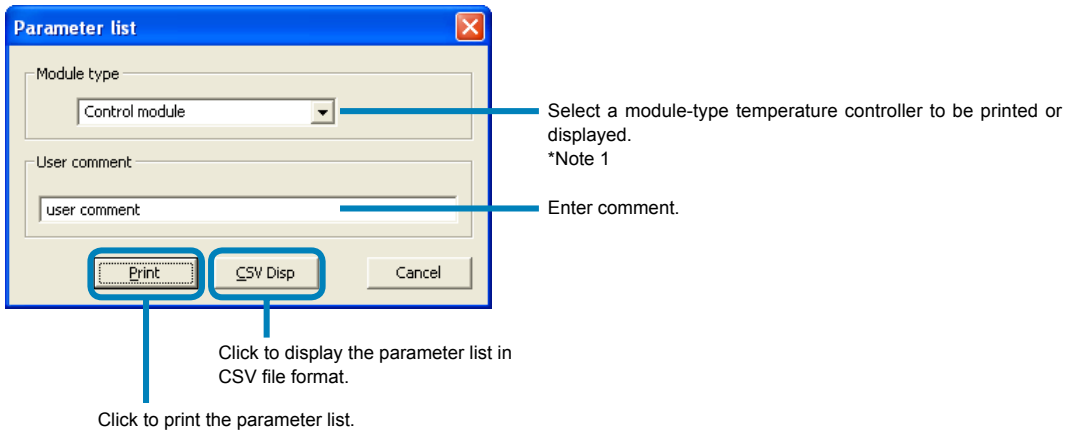

\* Note1: The module type is not selectable when starting up with the enhanced communication module.

---

**Note**

- The entered contents may be automatically converted into Excel format depending on the contents of the user comment.  
(Example: 4-20 → April 20)
  - The value "0" in fractional portion is not displayed in CSV format.
  - Printing is made on A4 paper in vertical orientation (fixed).
  - The setting display of the PUM parameter loader and the display of the printing/CSV output result may not be the same.  
Example: If the PUM parameter loader display = "0009," the result of printing/CSV output = "9."
  - If setting displayed in binary digit is printed or output in CSV format, the setting is displayed as a decimal number.  
Example: If DO1 optional function setting = "0101," the result of printing/CSV output = "101."
-

---

## Uploading (Transmission from PUM to PC)

---

The parameter setting of the module-type temperature controller can be received in batch.

- 1 Select "Upload (PC ← PUM data transmit) (U)" from the "Data (D)" menu of the "PUM loader – PUM Parameters Support" screen (on P.23).

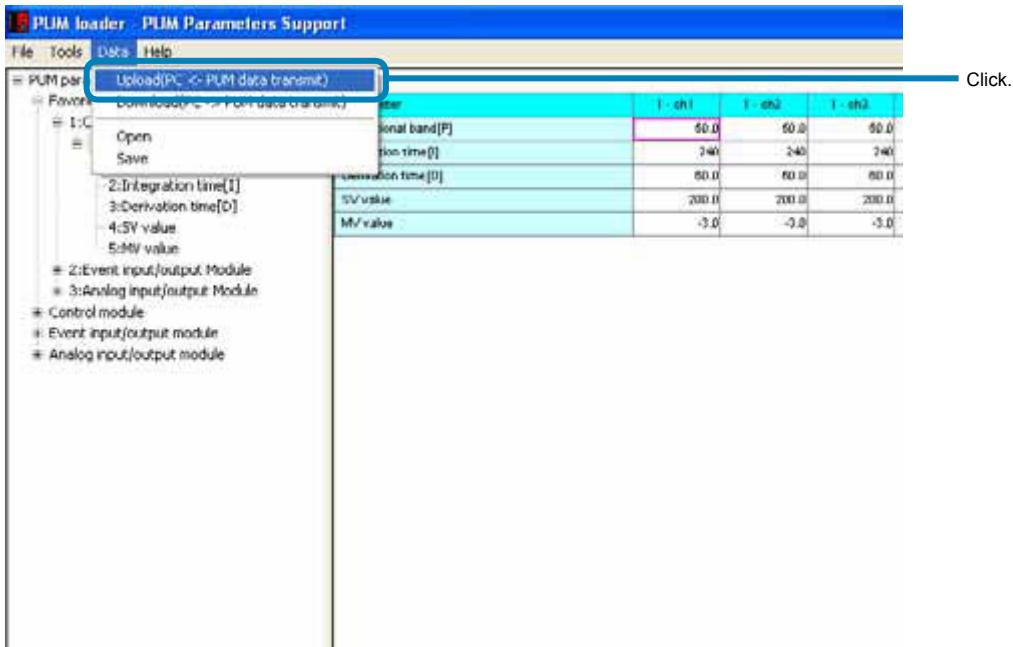

- \* Proceed to **2** when selected the "control/event/analog" on the "module type selection".
- \* Proceed to **3** when selected the "enhanced communication module" on the "module type selection".

- 2 Check the ST Nos. of the module-type temperature controllers to be uploaded on the “Station definition” screen, and then click [OK].

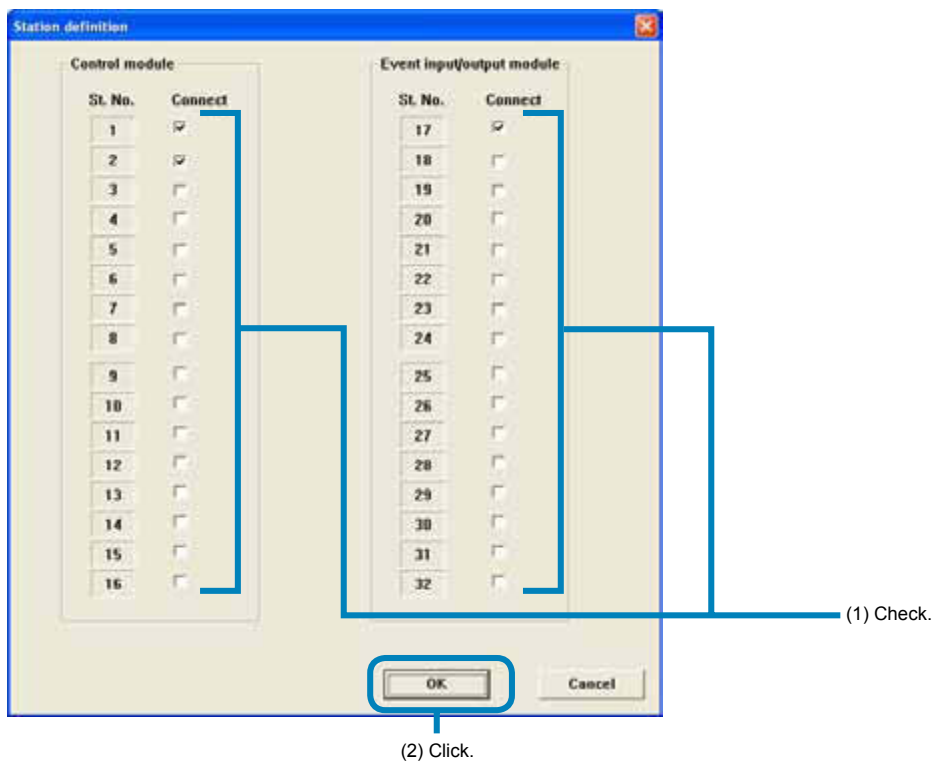

Proceed to 4.

#### Note

Do not check the box of the module not connected.

- 3 Click [OK] on the “PUM loader” screen.

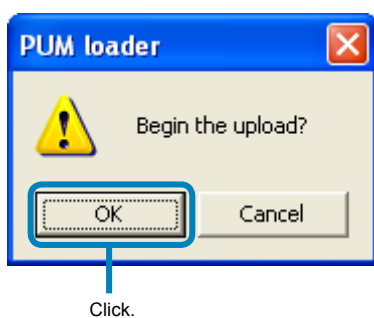

#### ■ To cancel uploading

Click [Cancel] .

4 Click [OK] on the “PUM loader” screen.

Click [OK] to save the parameter setting currently selected.

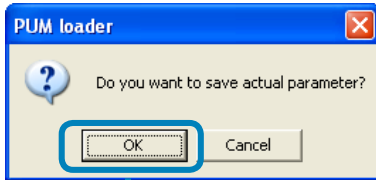

Click.

■ **Not to save the parameter setting currently selected**

Click [Cancel] .

5 Select the file to which the parameter setting is to be saved on the “Save as” screen, and then click “Save.”

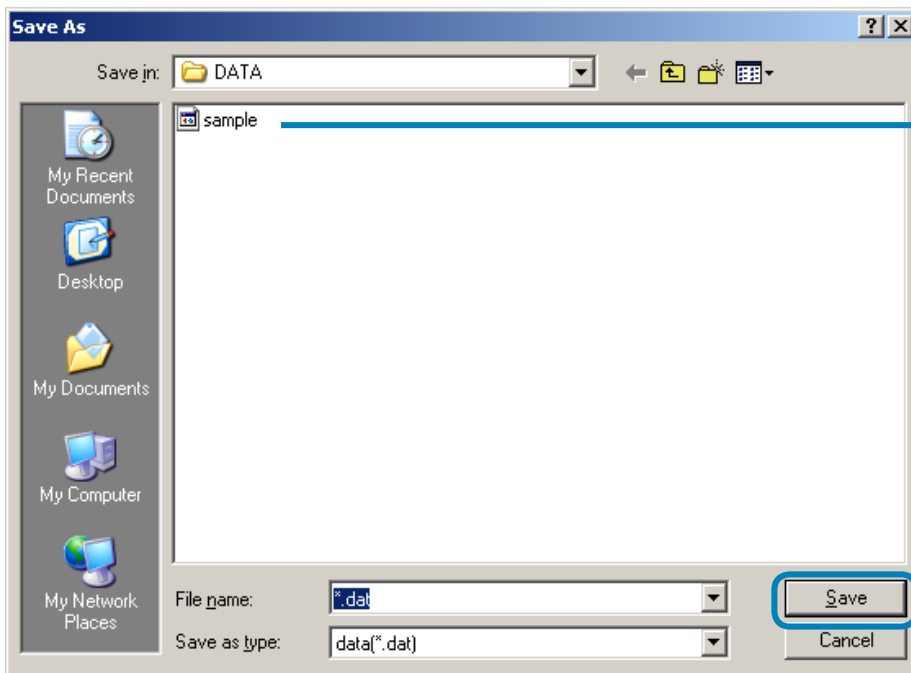

(1) Select the file in which the parameter setting is to be saved.

(2) Click.

#### Note

- Approximately 20 seconds are required for uploading per module-type temperature controller. Do not perform other communication operations while the settings are read.
- Do not turn off the power of the module-type temperature controller while the settings are read.
- Do not pull out the loader connection cable while the settings are read.

## Downloading (Transmission from PC to PUM)

Parameter settings can be transmitted to the connected module-type temperature controllers.

- 1 Select “Download (PC → PUM data transmit (D))” from the “Data (D)” menu of the “PUM loader – PUM Parameters Support” screen (on P.23).

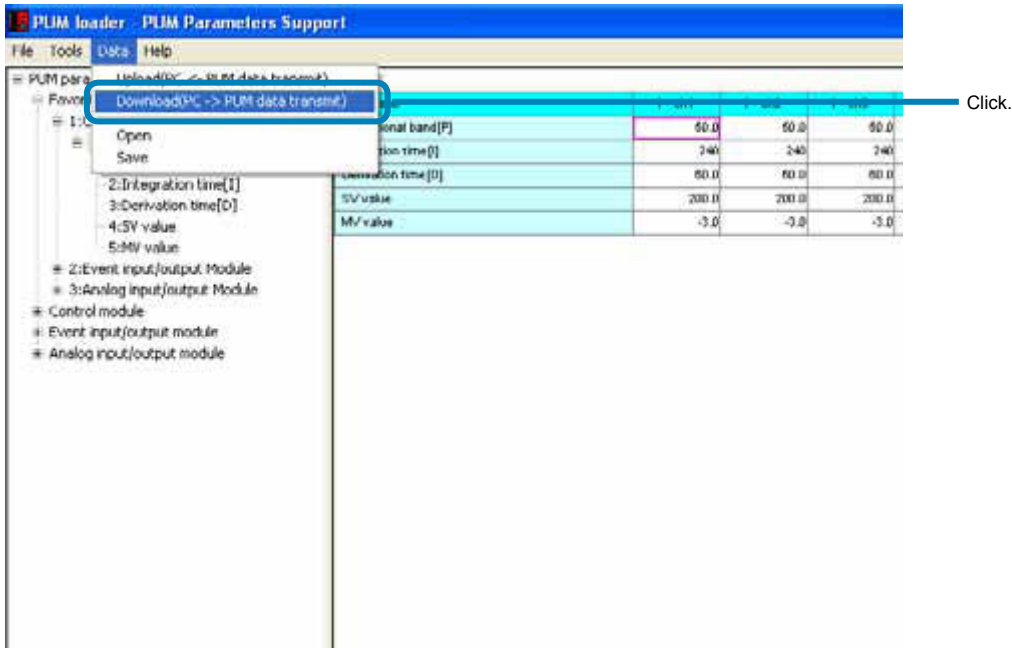

\* Proceed to **2** when selected the “control/event/analog” on the “module type selection”.

\* Proceed to **3** when selected the “enhanced communication module” on the “module type selection”.

- 2 Check the St Nos. of the module-type temperature controllers to be downloaded on the “Station definition” screen, and then click [OK].

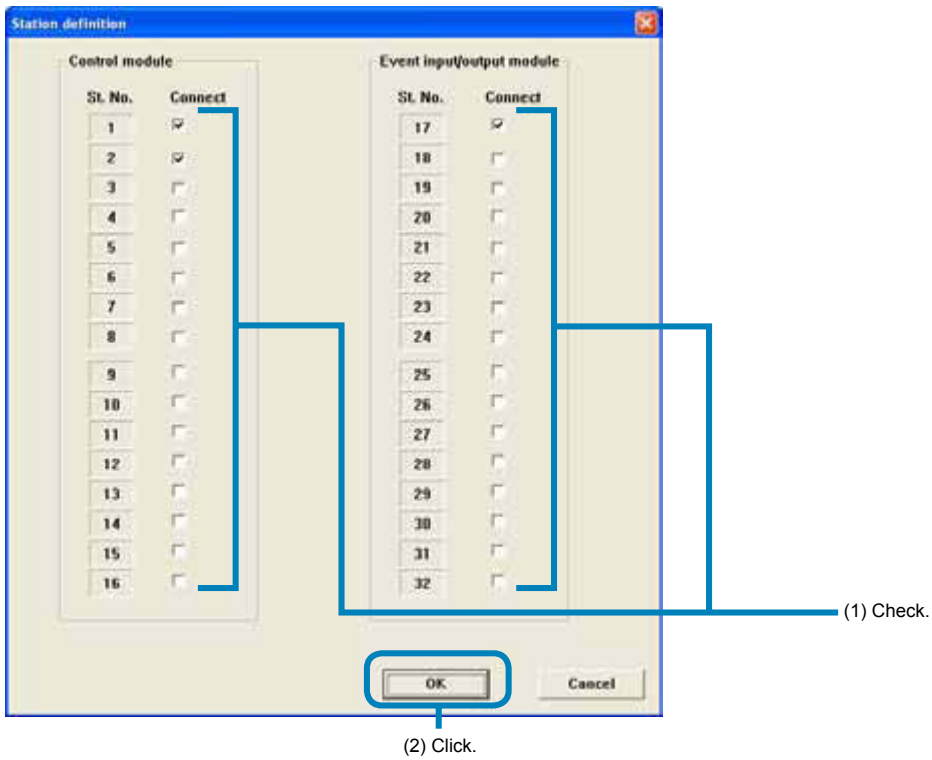

**Note**

Do not check the box of the module not connected.

■ **To cancel downloading.**

Click [Cancel] .

- 3 Click [OK] on the “PUM loader” screen.

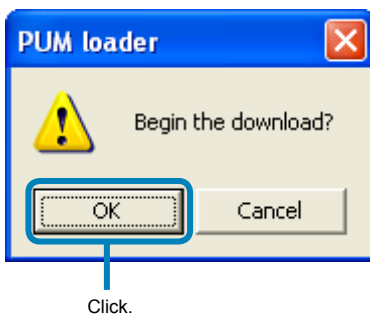

■ **To cancel downloading.**

Click [Cancel] .

---

**Note**

- Approximately 20 seconds are required for downloading per module-type temperature controller. Do not perform other communication operations while downloading.
  - Do not turn off the power of the module-type temperature controller while downloading.
  - Do not pull out the loader connection cable while downloading.
  - Do not carry out downloading with the auto tuning start command set at "1."
  - Check that the main unit reset is set to "0," communication permit setting to "1," and that the master/slave data is correct, and then carry out downloading.
-

## Opening files

Data saved in a file can be read.

- 1 Select "Open" from the "Data" menu of the "PUM loader – PUM Parameters Support" screen (on P.23).

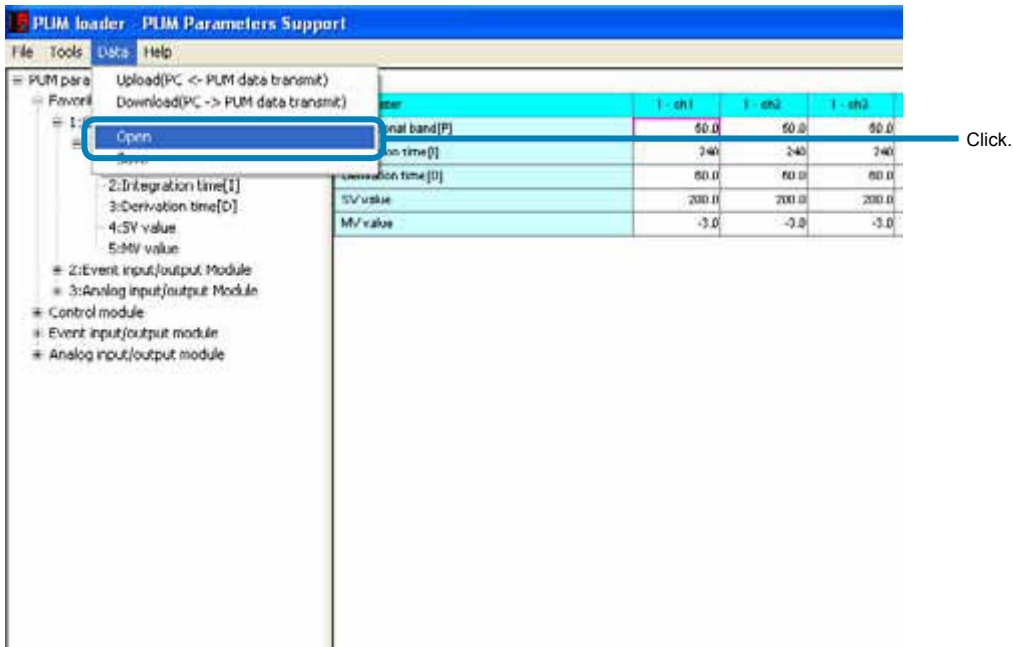

- 2 Click [OK] on the "PUM loader" screen.

Click [OK] to save the parameter setting currently selected.

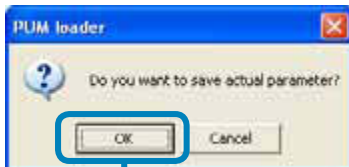

Click.

- **Not to save the parameter setting currently selected.**

Click [Cancel].

- 3** Select a file to which the parameter setting is to be saved on the “Save as” screen, and then click [Save (S)].

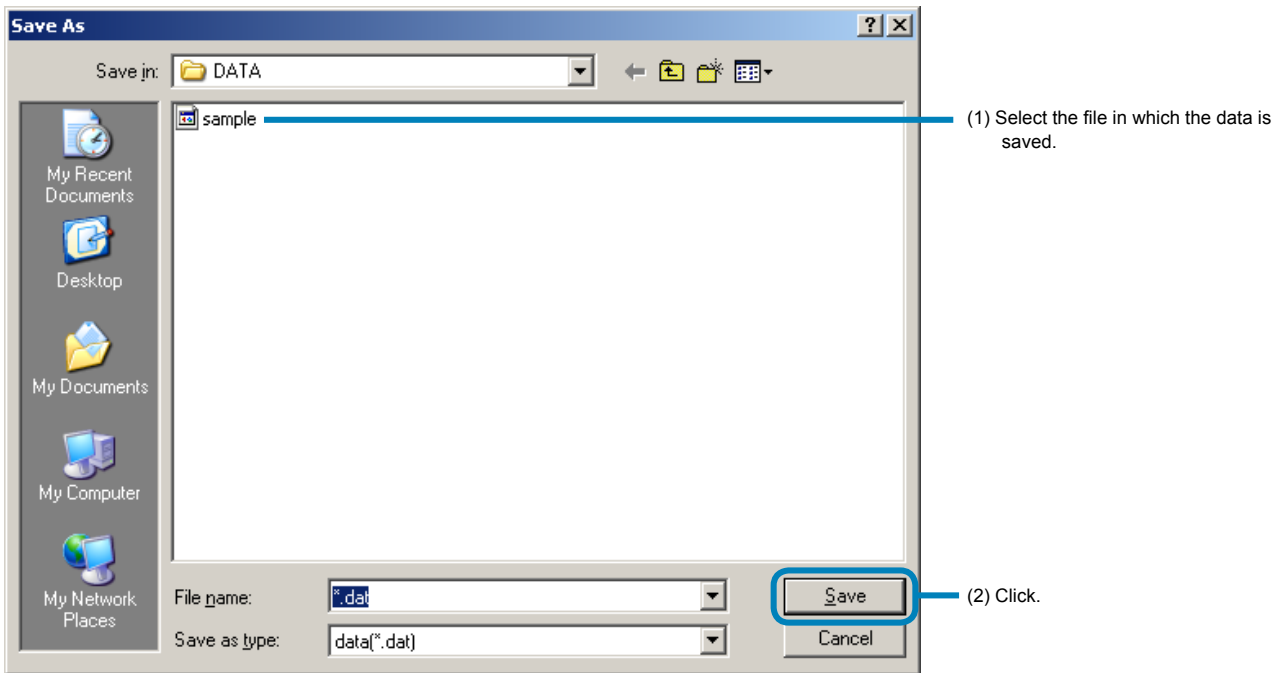

- 4** Select the desired file on the “Open” screen, and then click [Open].

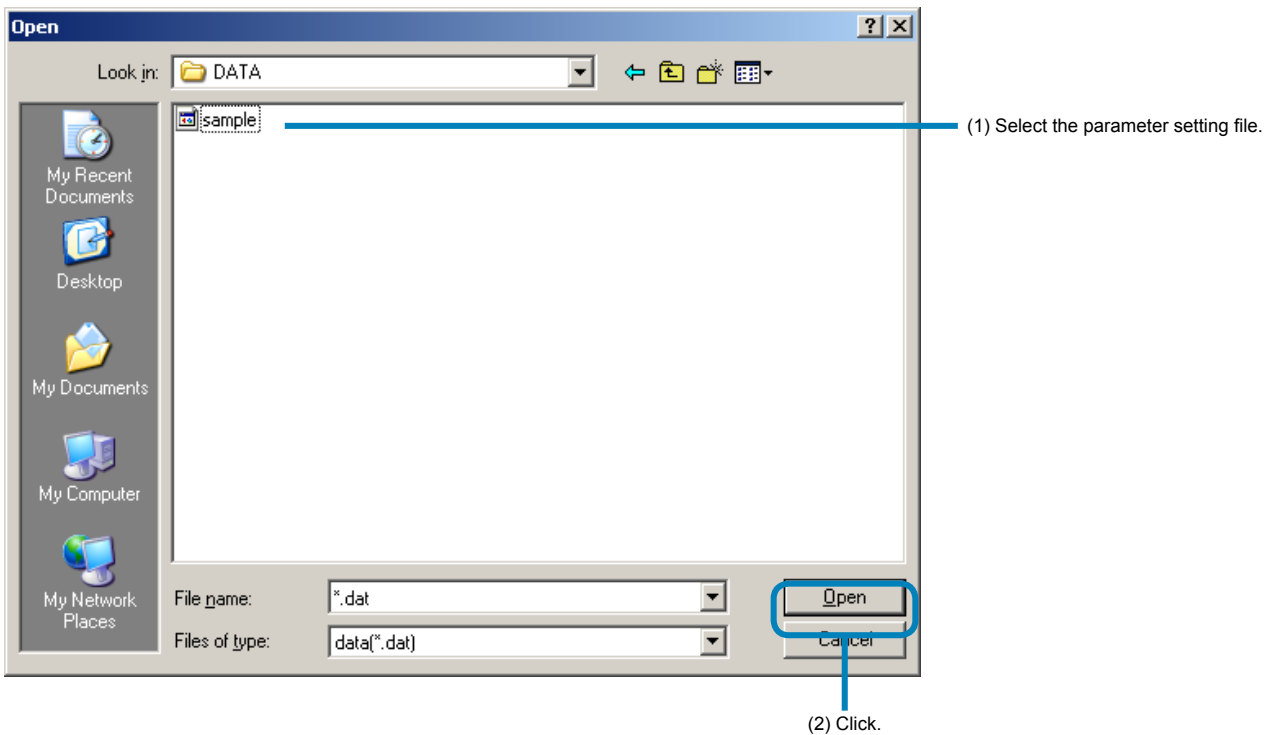

## Saving the setting in a file

The current parameter settings can be saved in a file.

- 1 Select "Save" from the "Data" menu of the "PUM loader – PUM Parameters Support" screen (on P.23).

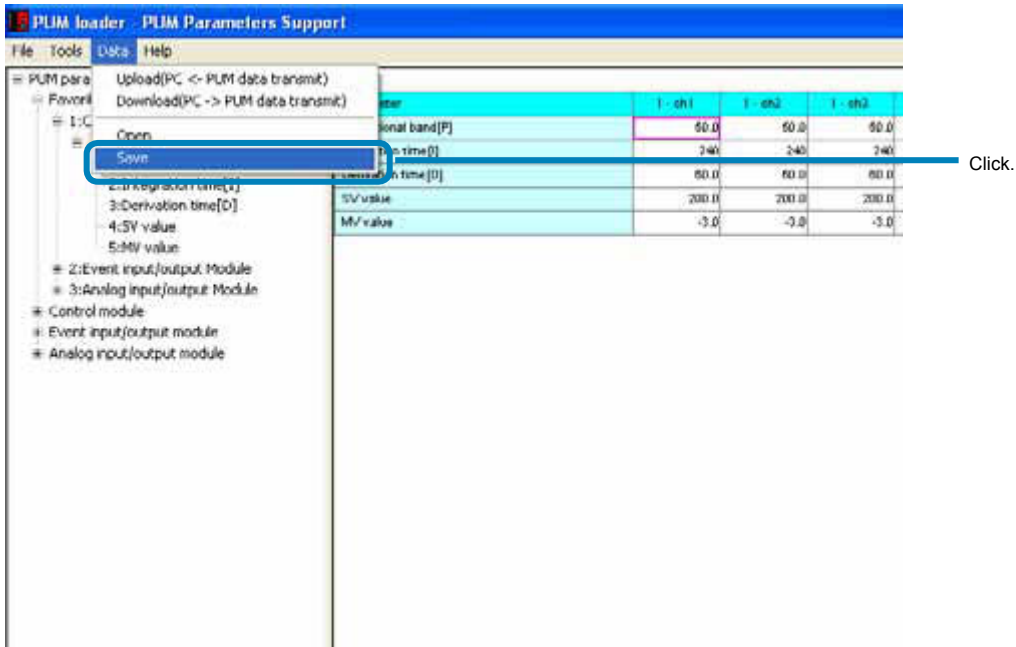

- 2 Select the file in which the parameter settings are to be saved on the "Save as" screen, and then click [Save].

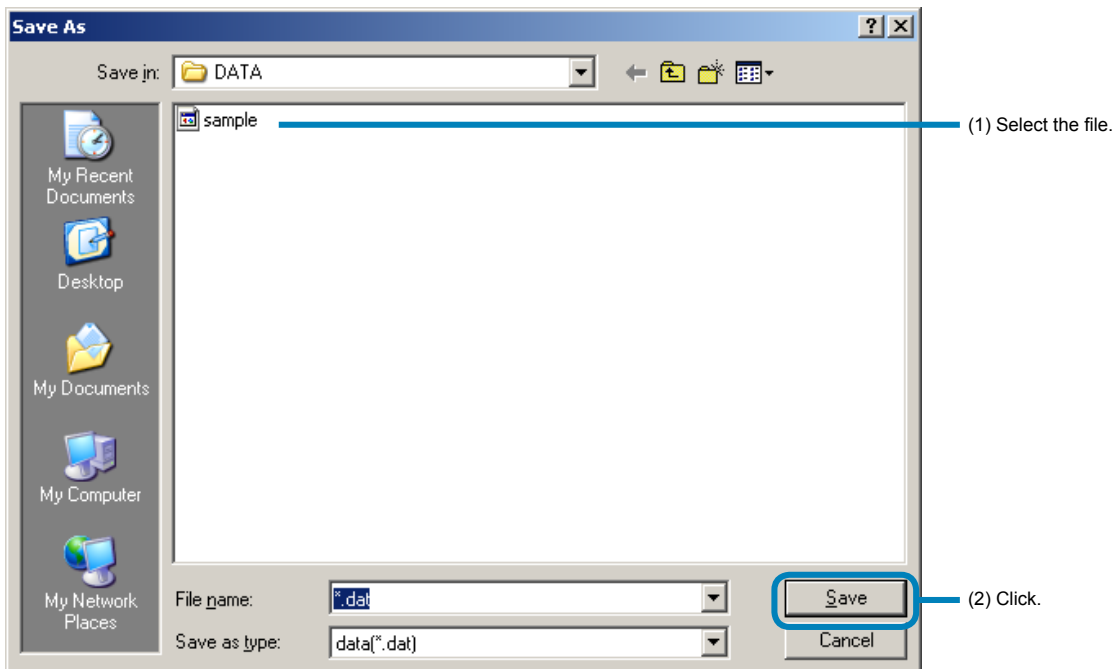

---

## Exiting the PUM parameter loader

---

Exit the PUM parameter loader as follows.

- 1 Select "Exit" from the "File" menu of the "PUM loader – PUM Parameters Support" screen (on P.23).

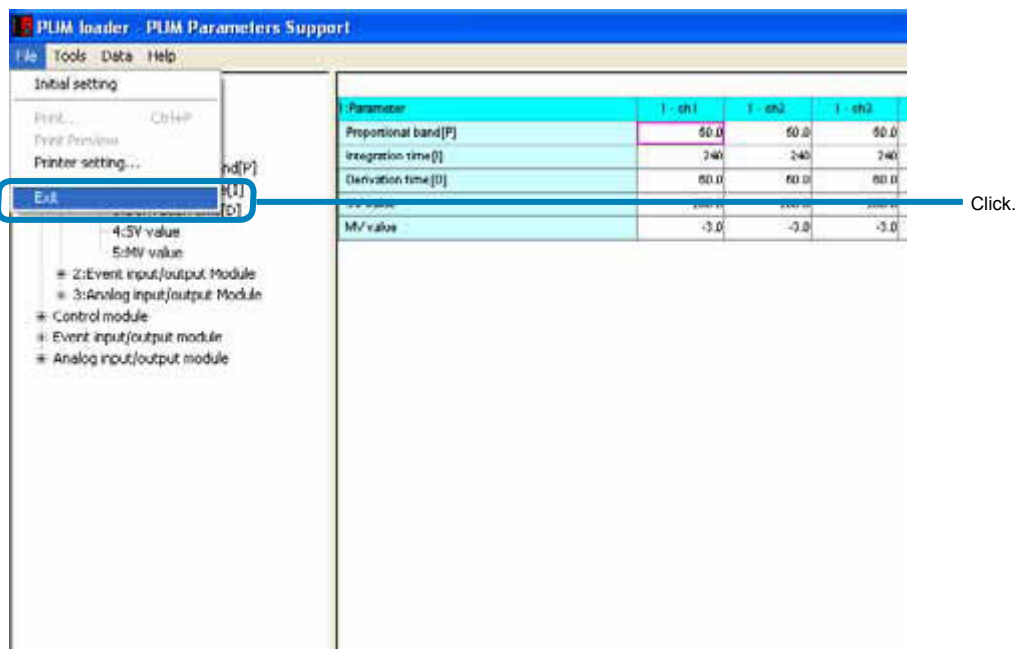

- 2 Click [Yes] on the "Exit" window.

Click [Yes] to save the parameter setting currently selected.

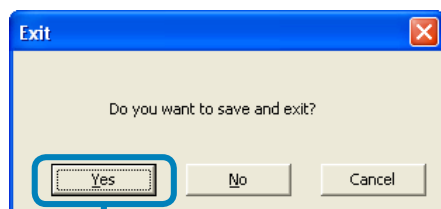

Click.

■ **Not to save the parameter setting currently selected**

Click [No].

■ **To cancel the exit from PUM parameter loader**

Click [Cancel].

- 
- 3** Select a file in which the data is to be saved on the “Save as” screen, and then click [Save].”

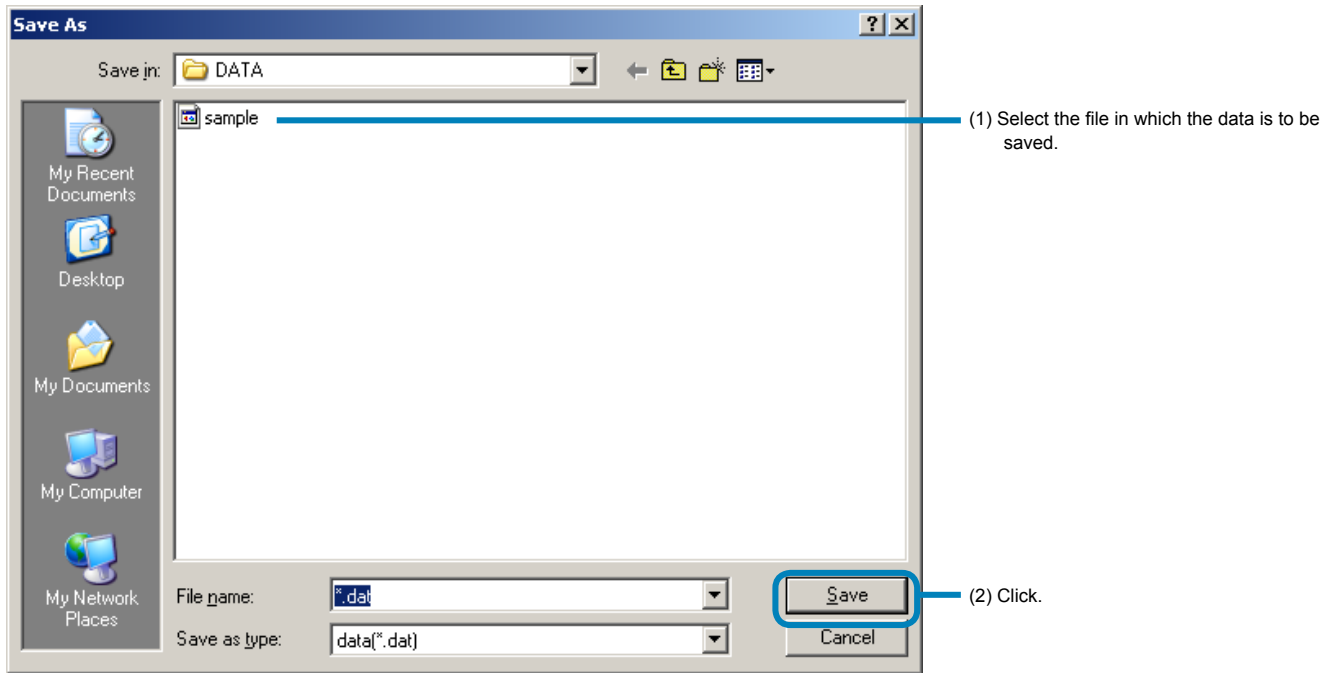

# 9 Troubleshooting

The following table lists the trouble symptoms that may appear when the setting of the module-type temperature controller is made using the PUM parameter loader, their causes, and remedies.

Trouble	Causes	Solution
None of the connected module is capable of communicating with the loader software.	Improper PUM parameter loader software connection	Check that the PUM parameter loader software and the modules are connected properly.
	Improper connection of the PUM parameter loader connecting cables	Check the connection of the PUM parameter loader connecting cable. Check if the cable is break or not.
		Check if the assembly of the PUM parameter loader connecting cable is proper or not.
	Improper station No. setting	Check if communicating to the correct station number.
		Check if the set station number is duplicated.
	Incompatible communication conditions	Check that the communication specifications of the loader software and those of the module are compatible.
Several master are defined.	Define only one master.	
Only some of the connected modules cannot communicate with the PUM parameter loader.	Improper PUM parameter loader software connection	Check that the loader software is connected to the master of internal communication between modules.
Parameters can not be changed.	RS-485 communication permission is set to "Read only".	Change the setting to "Readable/Writable".
	The parameter input value tried to write the value out of the setting range	Change the parameter input value to the one in the setting range and then write again.
Parameter setting that has not been changed is changed.	SV value may be changed as a result of changing the SV value.	Set the SV limit value larger than the SV value. Set the SV value within the SV limit value range.
	The parameter set value for industrial value display is automatically changed by change of PV input type, PV scale (Analog input type, Analog input scale for Analog module), decimal point position, unit display.	—
	Alarm settings are automatically changed depending on the setting of DO output event type.	—
Parameters are displayed as "-" after uploading/downloading.	Communication error may be occurring.	Check the communication environment. Check the master/slave setting in connected modules.
Online mode cannot be used.	Online mode cannot be used if startup is carried out by clicking "File selection startup mode".	Start from "Startup mode/Module data reception launch mode".
Data display is not updated when parameters are copied.	The tree display is not updated.	Click the parameters on the parameter tree display (on the left side of the screen) to update the tree.
"Communication port does not open" is displayed.	Multiple communication programs have been started.	Terminate the all communication program, and then restart the PUM parameter loader.