

Thank you for purchasing our Single-phase Power Controller PA-3000-HZ series.

This manual contains instructions for the mounting , functions, operations and notes when operating the PA-3000-HZ.

To prevent accidents arising from the misuse of this instrument, please ensure the operator receives this manual.

CONTENTS

	Page
 Safety Precautions -----	2
1. Name of the sections -----	3
2. Installation -----	4
3. External dimensions -----	6
4. Settings -----	6
5. Wiring -----	8
6. Operation -----	12
7. Maintenance -----	12
8. Accessories sold separately -----	13
9. Troubleshooting -----	14
10. General specifications -----	15

■ Model label

The model label is attached to the upper side of this unit.

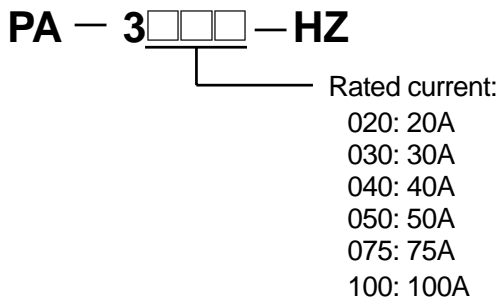
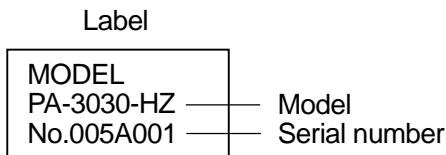

■ Accessories included

Instruction manual, 1 copy

SAFETY PRECAUTIONS







1. Preconditions for use

This unit is designed to be used in an indoor instrumentation panel.

2. Symbols used for this unit and manual

● Used in this unit

● Used in this manual

Label	Meaning	Label	Meaning
 Alert symbol mark	Caution when handling for prevention of an electric shock, accidents or injuries	 Warning	Procedures which may lead to dangerous conditions, death or serious injury
 Caution high temperature	Caution for a hot point (heat radiation fin) –for burn prevention	 Caution	Procedures which may lead to dangerous conditions, superficial to medium injury or physical damage or damage to the product
 Grounding terminal	To avoid an electric shock, connect grounding section (mounting hole) to the protective conductor terminal of the power supply equipment.		
RATING □□A Rated current	Indicates rated current. Please make sure that max. load current is lower than the rated current.	 Note	Notes useful for handling and operation of this unit

3. Overview

This compact and light weight single-phase power controller is designed for high density panel installation, and can be applied to a wide range of heating control applications with its various functions including phase-angle firing system/zero-cross firing system selection, soft start time setting and lower-limit setting.

Warnings/Cautions

(1) Mounting direction

Mount your unit vertically with its main circuit terminals (U1, U2) placed downward to ensure air-cooling effects are ventilated through the air duct structure.

(2) Do not use this unit on any desk.

Make sure to mount this unit on a panel to prevent malfunction or injury through it falling down.

(3) Mounting environment

Do not operate this unit at a place where explosive, inflammable gas or other dangerous vapors exist.

(4) Only Shinko or qualified service personnel may handle the inner assembly.

To prevent an electric shock, accident, fire or other problem, repair, modification or disassembly of the unit may only be undertaken by Shinko or qualified service personnel.

(5) Turn the power supply off in case of any abnormal events.

If there are abnormal odors, heat, or other abnormal events, turn the power supply off, and inform the nearest agent of the Shinko Technos. Co., Ltd.

■ For safety and security

(1) Use your unit at lower than the rated current.

Confirm the rated current on the label attached on the upper side of the unit.

(2) Connect a load before turning the power supply on.

Never turn the power supply on without connecting a load in advance to prevent problems.

(3) Applicable load

A resistive load is applicable. An inductive load (transformer primary control, maximum magnetic flux density 1.25T) is applicable only when the phase-angle firing system is selected.

(4) Mounting of a rapid fuse

Mount a rapid fuse (sold separately) for protecting thyristor elements.

(5) Countermeasures for digital units

Higher harmonic noises are generated when this unit is used with the phase-angle firing system. Use an insulation transformer, separate your unit from a drive power line, or take other countermeasures.

(6) Do not use unused terminals.

Do not connect signals to any unused terminals to prevent problems.

1. Name of the sections

The units' appearance is sorted into 3 kinds according to the rated current. The following appearance is the 30A type. The appearance of other types is almost the same as this 30A type.

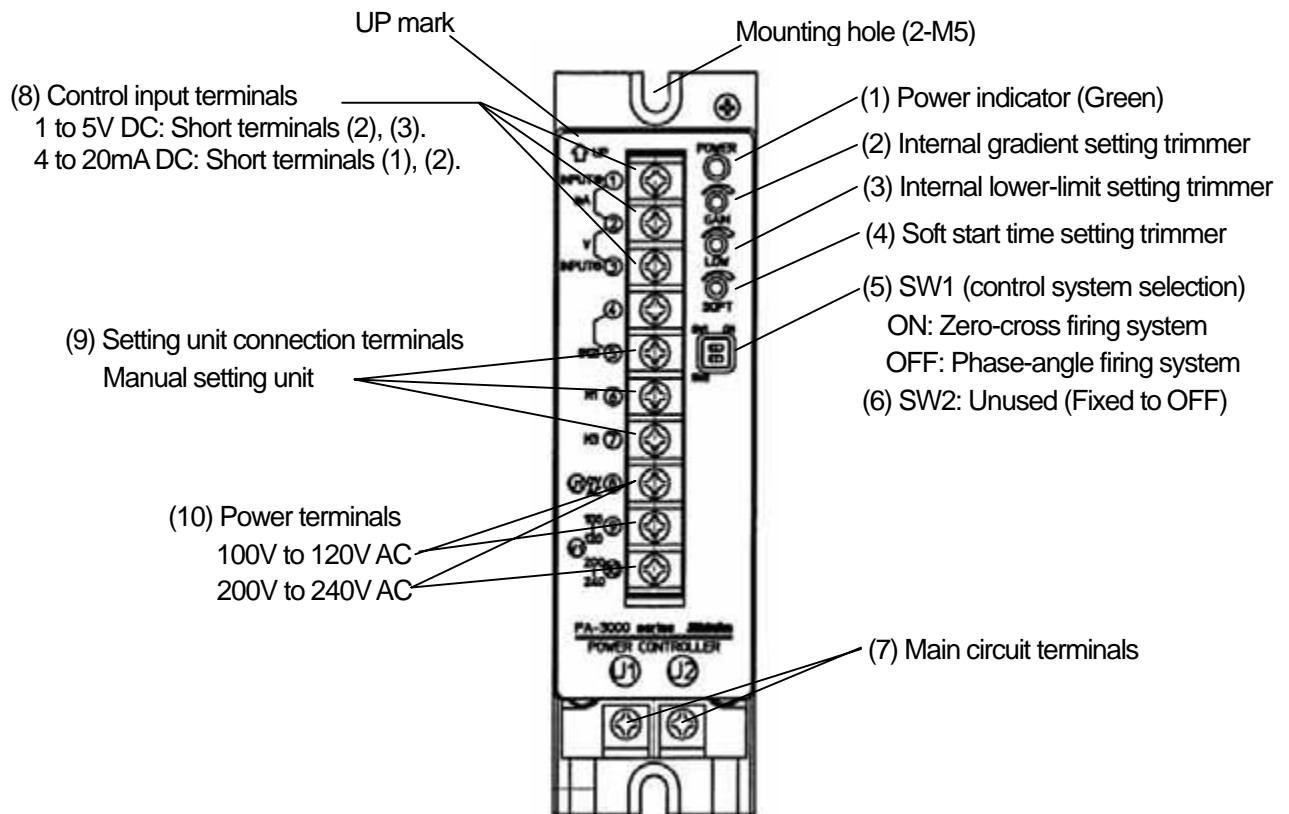

(1) Power indicator

Lights (green) when power is supplied to power terminals (8) (9) and (10).
Flashes while identifying the frequency after the power is turned on.

(2) Internal gradient setting trimmer

Gradient setting is possible. 100% when turned fully to the right (clockwise) ↻.
Generally used at 100%.
For Current/Voltage input, the gradient setting unit is installed externally.

(3) Internal lower-limit setting trimmer

Output value when control input is 0% (terminal (H) is connected to (C)) can be set.
The output value becomes 0% when it is turned fully to the left (counterclockwise) ↺.
Generally used at 0% position.
For the contact input, the lower-limit setting unit is also installed externally.

(4) Soft start time setting trimmer

Soft start time can be set. When it is turned fully to the left (counterclockwise) ↺: Approx. 1 second
When it is turned fully to the right (clockwise) ↻: Approx. 20 seconds

(5) SW1: Switches Zero-cross firing system (ON) or Phase-angle firing system (OFF).

(6) SW2: Not used. Be sure to switch this to the OFF position.

(7) Main circuit terminals: Terminals for main circuit (U1, U2) running to the thyristor element.

(8) Control input terminals: Input terminals for current (4 to 20mA DC) or voltage (1 to 5V DC) signal to control the output

(9) Setting unit connection terminals:

For Current/Voltage input: Terminals to connect the gradient setting unit or manual setting unit externally

For Contact input: Terminals to connect output signals ((H), (C), (L)) from the controller with upper-limit and lower-limit setting units

(10) Power terminals:

Terminals for supplying power to the power controller

100 to 120V AC: Terminals 8 and 9

200 to 240V AC: Terminals 8 and 10

2. Installation

Warning

Turn the power supply to the instrument off before installation.
 Working or touching the terminal with the power switched on may result in severe injury or death due to Electric Shock.
 This instrument is a back panel type which is designed to be mounted inside a panel except for accessories such as setting units.

2.1 Precautions for installation

- (1) Mount the unit with the UP mark () facing upward.
- (2) Mount the unit in a clean and well-ventilated place free of dust particles.
- (3) Separate this unit from a high temperature generating unit or similar unit.
- (4) Keep space for heat radiation (more than 200mm) above and below this unit.
- (5) Do not mount this unit in a place subject to vibrations and shocks.
- (6) Do not mount this unit in a corrosive gas atmosphere.
- (7) The rated current is specified at an ambient temperature of 40°C as a reference. If the ambient temperature exceeds 40°C, reduce the load current, referring to the right figure. (The maximum operating temperature is 55°C. Use this unit at a current lower than 80% of the rated current in this case.)
- (8) Ensure a secure and sufficiently strong mounting plate (panel) is used. (More than 1mm thickness is required for an iron plate.)

Note Mounting of accessories

Refer to "8. Accessories sold separately".

● Ambient temperature and allowable current

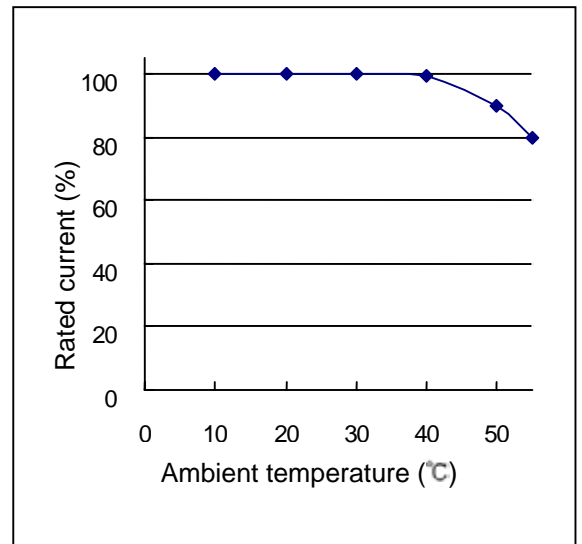

● Rated current and weight

Rated current	Weight
20A	Approx. 1.0kg
30A	Approx. 1.0kg
40A	Approx. 1.3kg
50A	Approx. 1.3kg
75A	Approx. 1.9kg
100A	Approx. 1.9kg

2.2 Mounting dimensions (unit: mm)

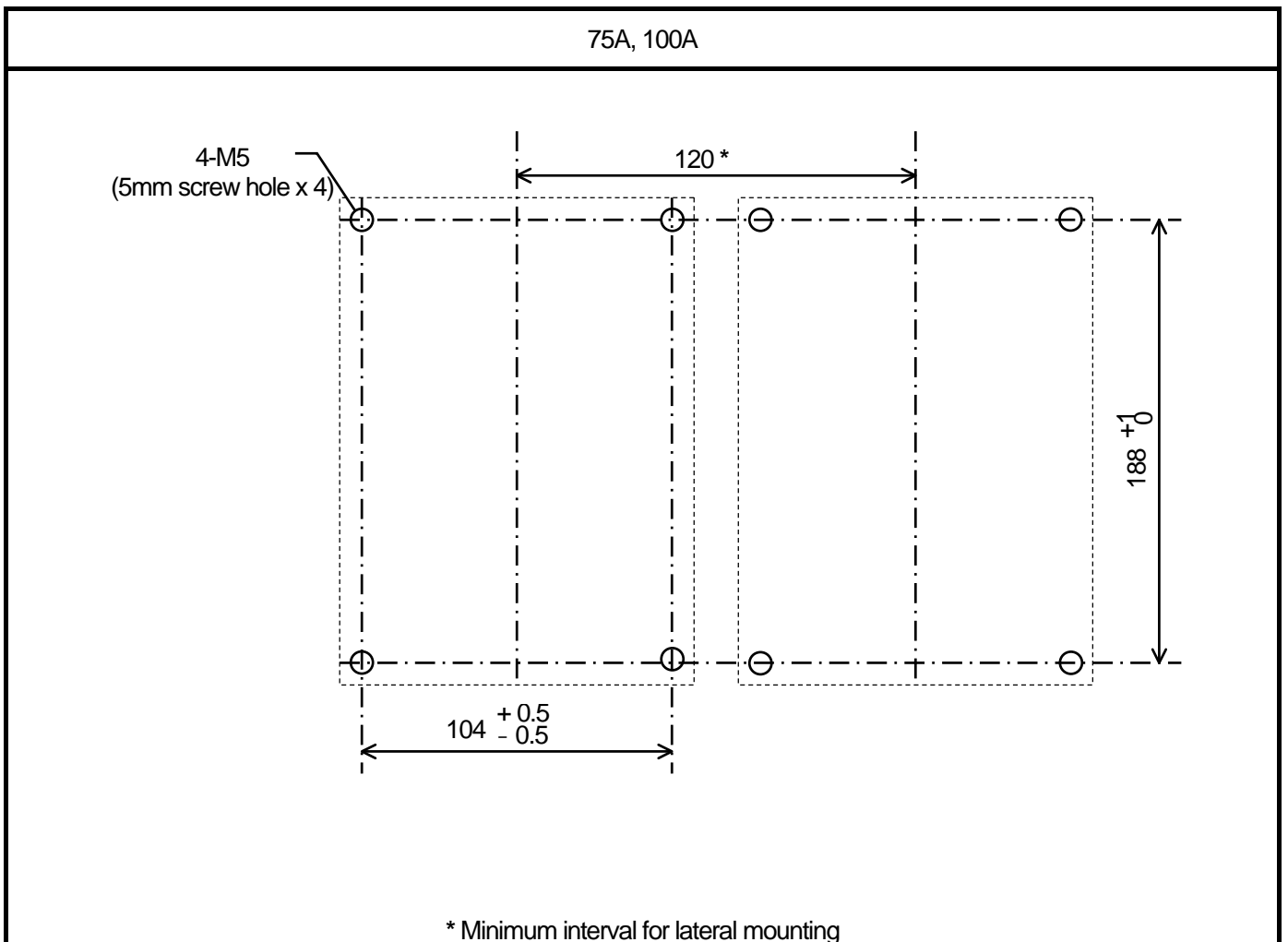
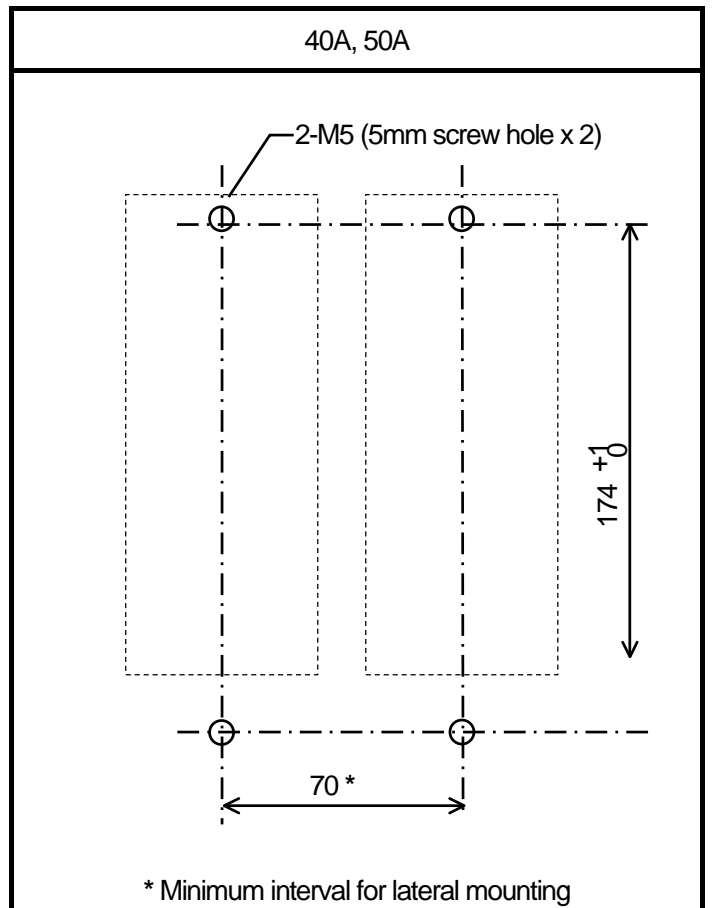
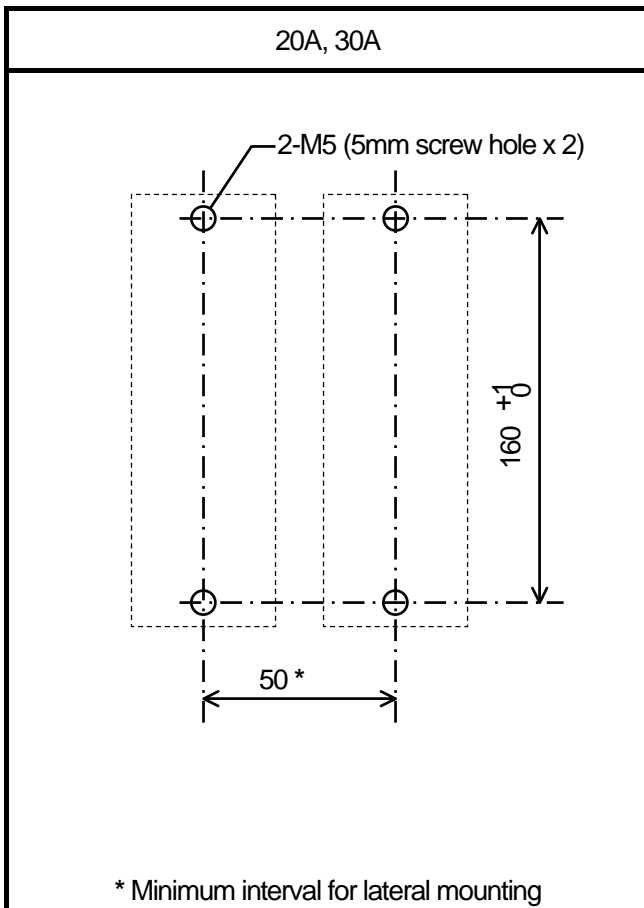

Note: Keep space for heat radiation of more than 200mm above and below this unit.

3.External dimensions (unit: mm)

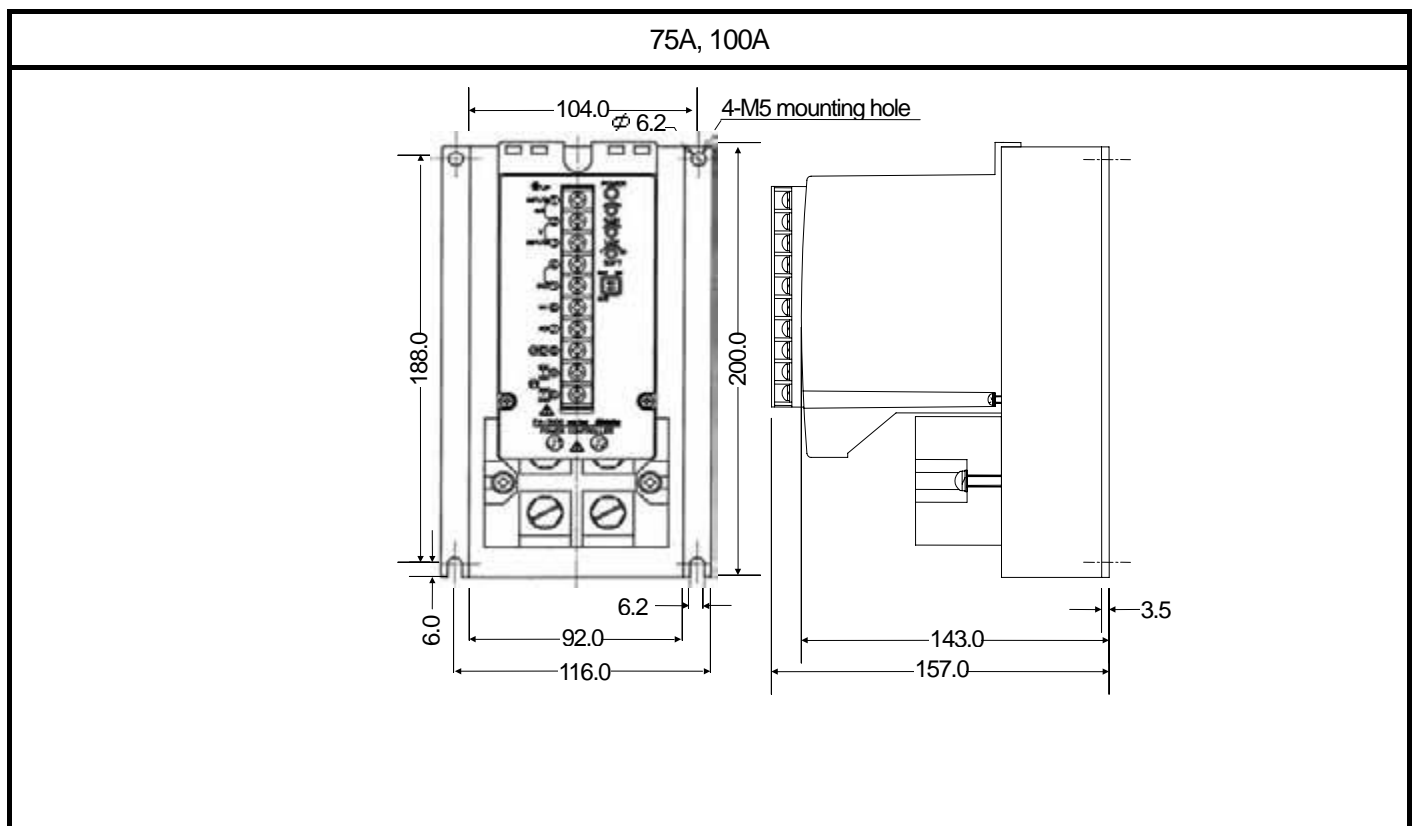
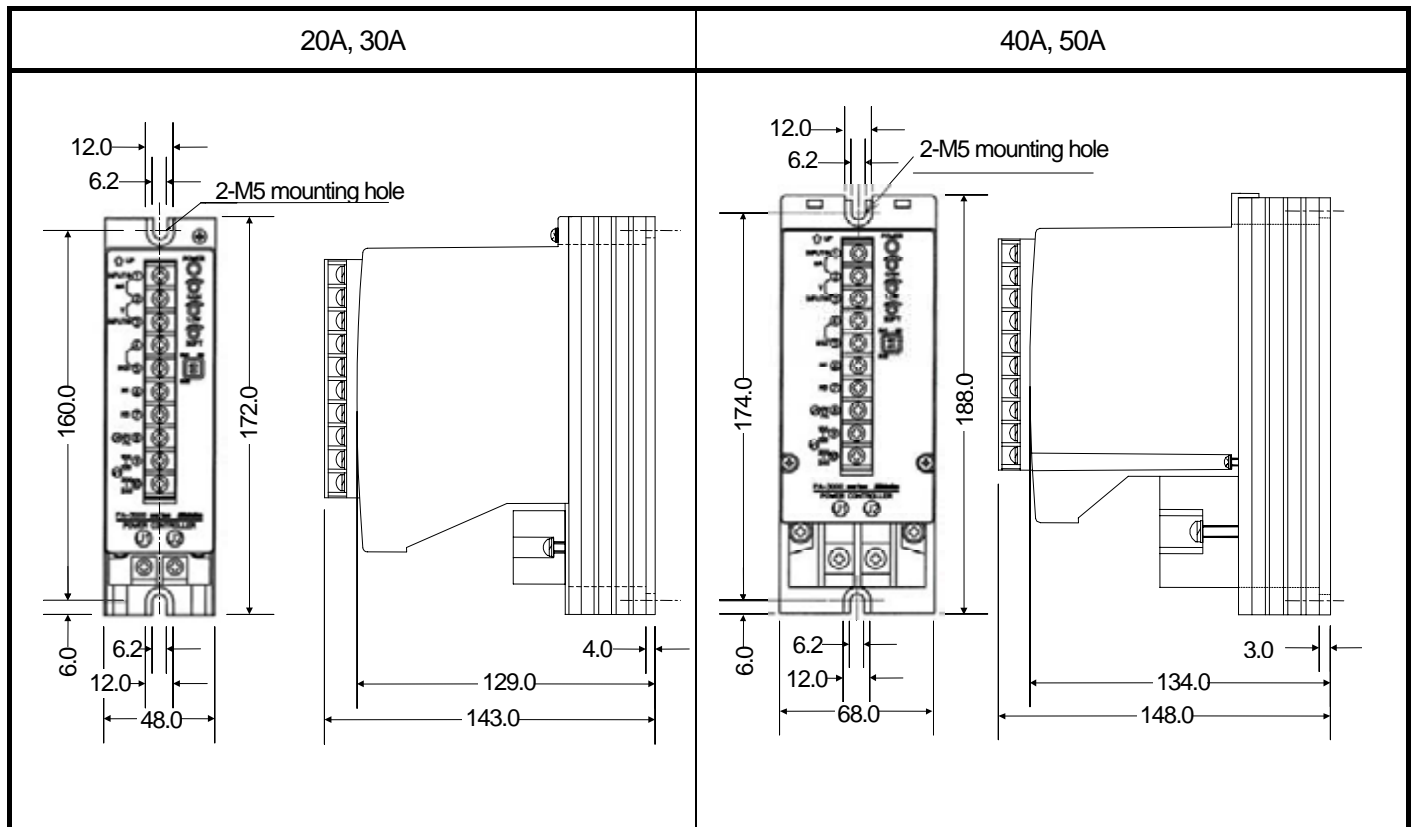

4. Settings

⚠ Caution

When changing the control system, it is recommended to turn the power source off.
 For the gradient setting and the lower-limit setting, change the settings gradually to avoid effecting the load or peripheral units by an abrupt change of output.

4.1 Control system selection (SW1)

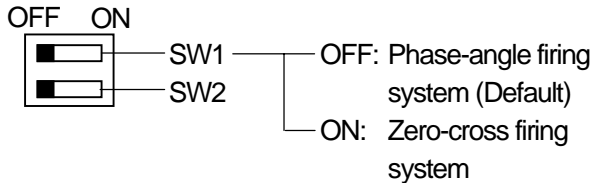

SW2: Not used (Fixed to OFF)

4.2 Gradient setting (GAIN)

External gradient setting unit	
Not connected	Connected
Set the gradient by this trimmer.	Set this trimmer to 100% and set the gradient by an external gradient setting unit.

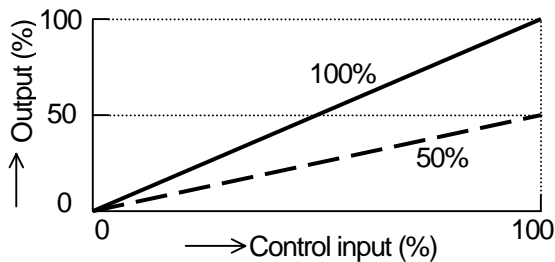

4.3 Lower-limit setting (LOW)

This trimmer is used to set the output value when the control input is 0%. Set this trimmer to 0% by turning it fully counterclockwise usually.

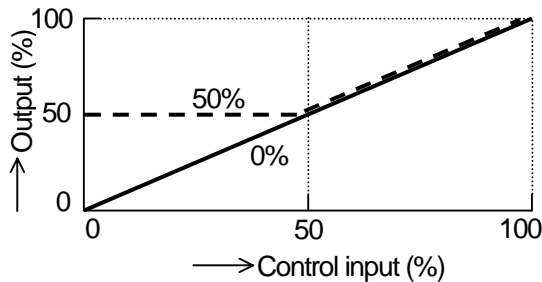

The above figure shows the lower-limit setting when the gradient is set to 100%.

4.4 Soft start time setting (SOFT)

The soft start time becomes approx. 1 second when turning this trimmer fully counterclockwise, and becomes approx. 20 seconds when turning this trimmer fully clockwise.

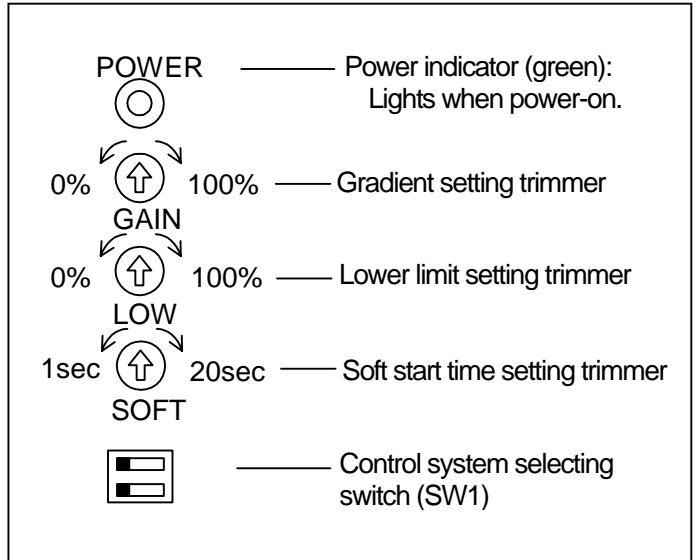

Control system

● Phase-angle firing system

The system for controlling the output by changing the conductive angle θ (ON timing) in the half cycle (180°) of the power supply. The control becomes continuous as compared with the zero-cross firing system. This control system is also used for transformer primary control. However, since the output contains higher harmonics, it may cause external noise.

● Zero-cross firing system

The system for controlling the output by deciding ON/OFF in every cycle of the power supply. Since the power supply is turned on from 0V (zero cross point) voltage, noise is reduced as compared with the phase-angle firing system. However, since the maximum current flows during each ON cycle it may cause flickering.

Soft start

This function is provided to increase the output gradually up to the specified output when the power supply is turned on or when the control input value changes abruptly. This function can prevent a surge current from being generated due to an abrupt change of the primary control output of transformer. You can set the time (from 0% to 100% output) from about 1 second to 20 seconds.

5. Wiring

Warning

- Turn the power source OFF before wiring to prevent an electric shock.
- Wiring should be undertaken by the experienced person who has a good knowledge of wiring.

5.1 Wiring precautions

- For the main circuit wiring, use a cable which has a sufficient allowance for load current.
- For wiring of the other terminals, twist 0.3 to 0.75mm² cables.

5.2 Main circuit terminals /Power terminals (U1, U2/ 8, 9, 10)

Make sure that the phase of the main circuit (U1, U2) is the same as the phase of the power supply (8, 9, 10). (U1 and 8, U2 and 9 or 10). If the phases do not match, normal output cannot be obtained.

(1) Main circuit voltage: 100 to 120V AC or 200 to 240V AC

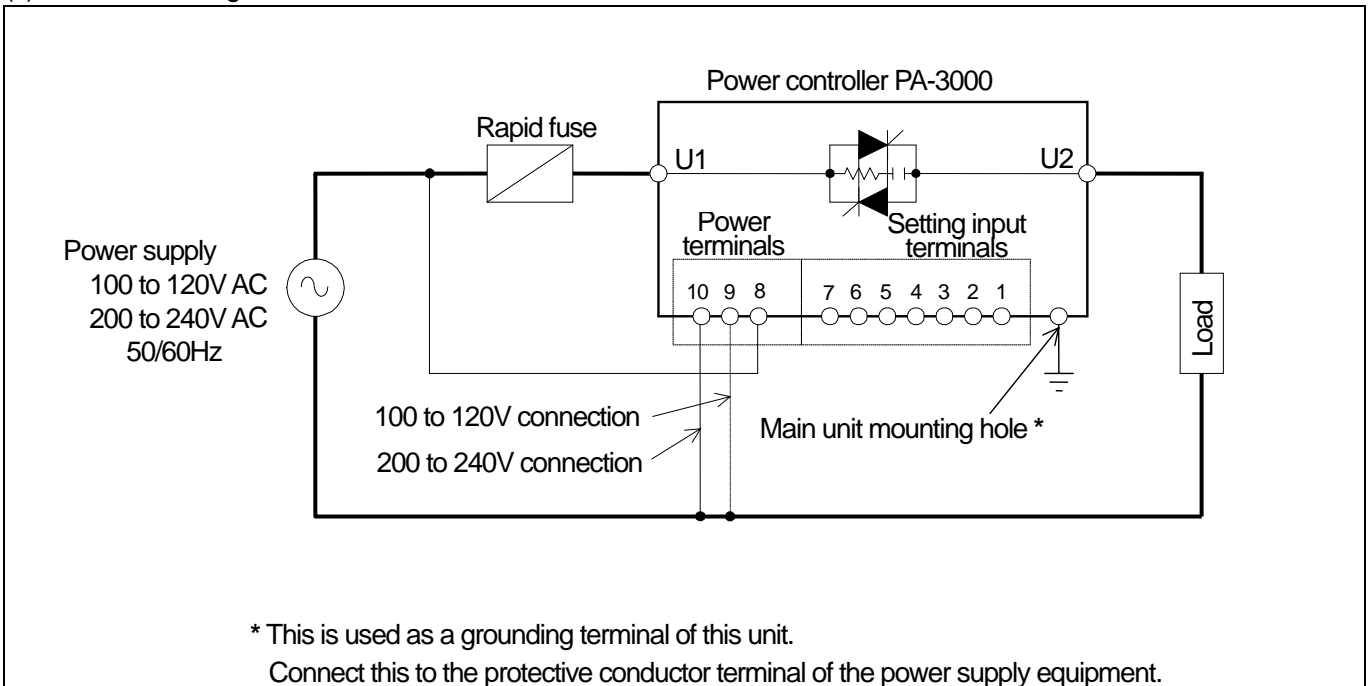

(2) Main circuit voltage: Voltages other than “100 to 120V AC” or “200 to 240V AC”

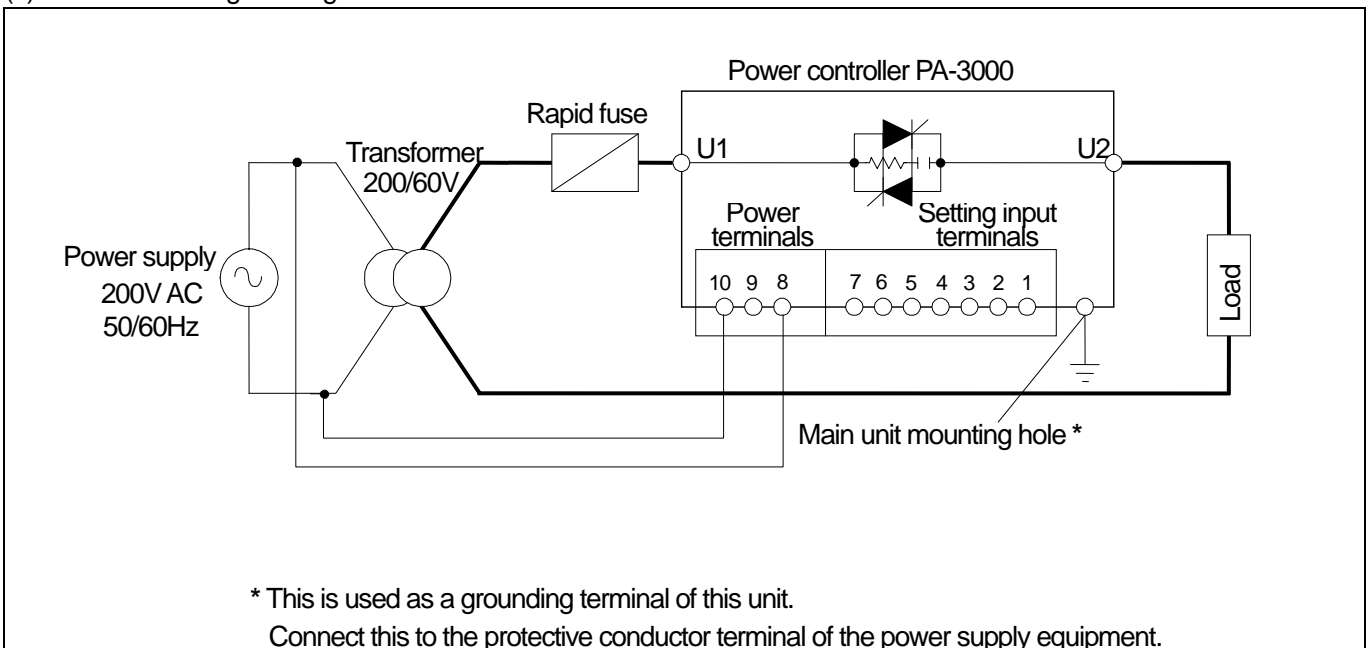

5.3 Setting input terminals (1 to 7)

5.3.1 Current/Voltage input signals

(1) Without a setting unit

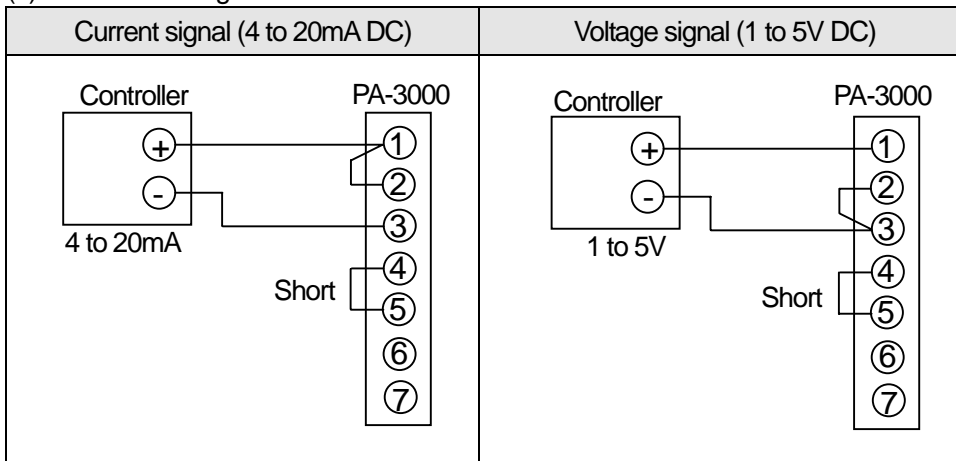

(2) Manual setting unit

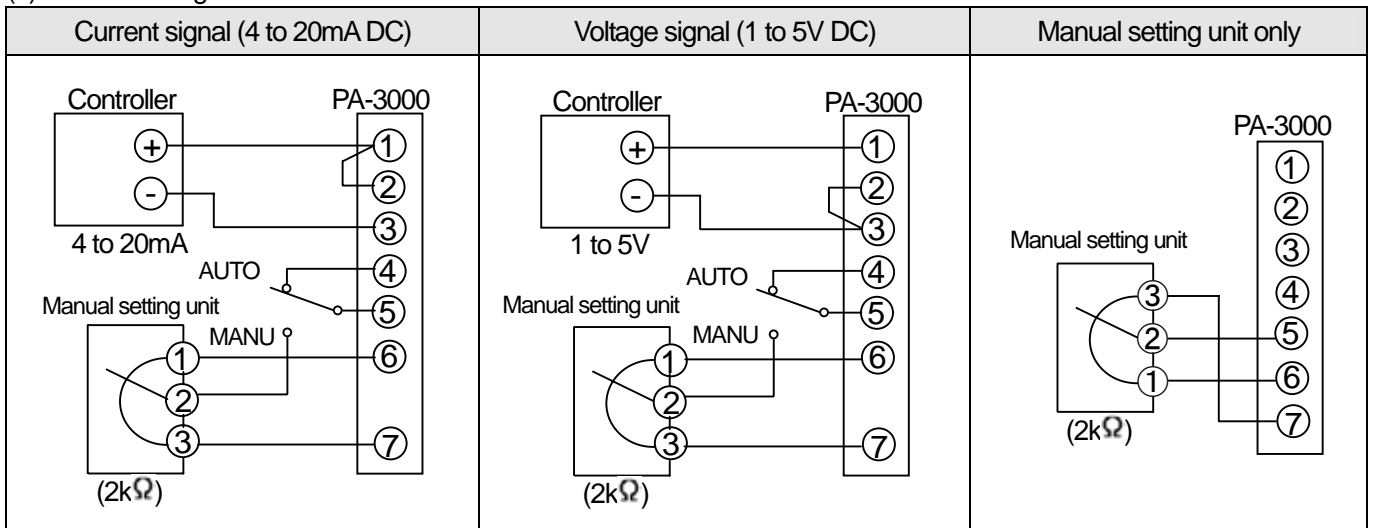

(3) Gradient setting unit

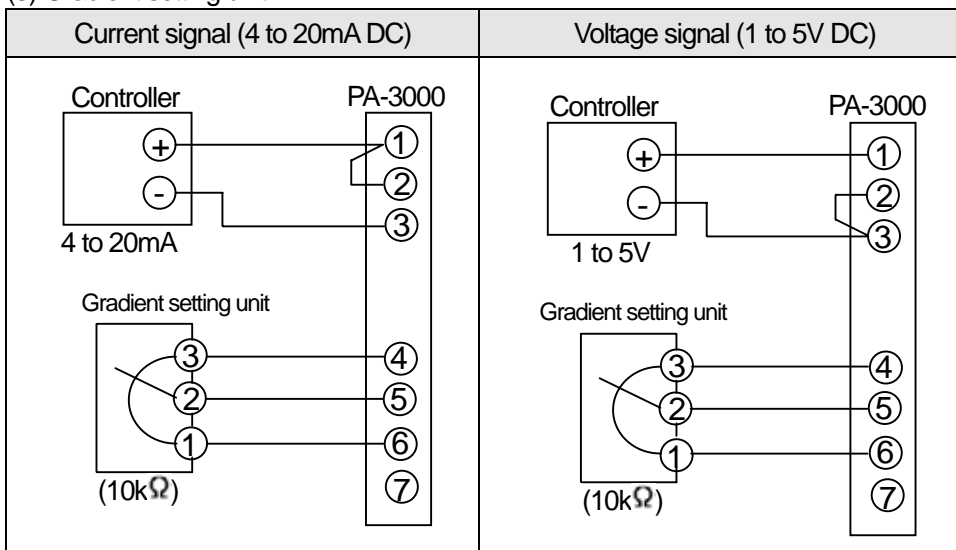

(4) Manual setting unit with gradient setting unit

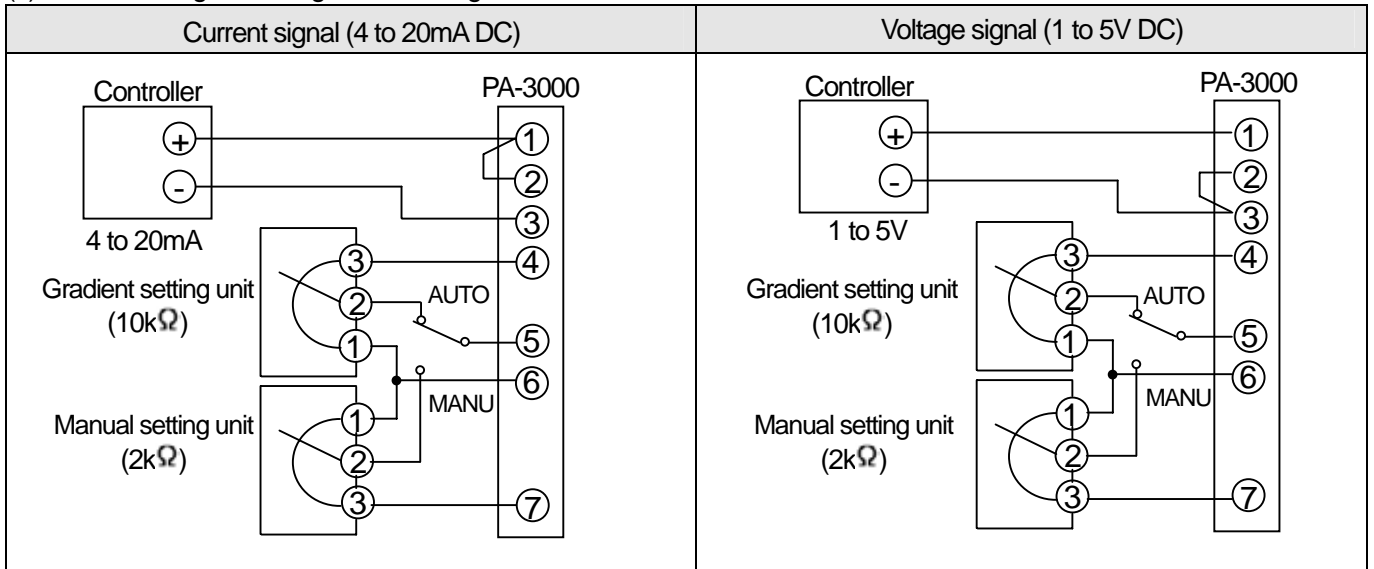

(5) 3 units running parallel (without setting units)

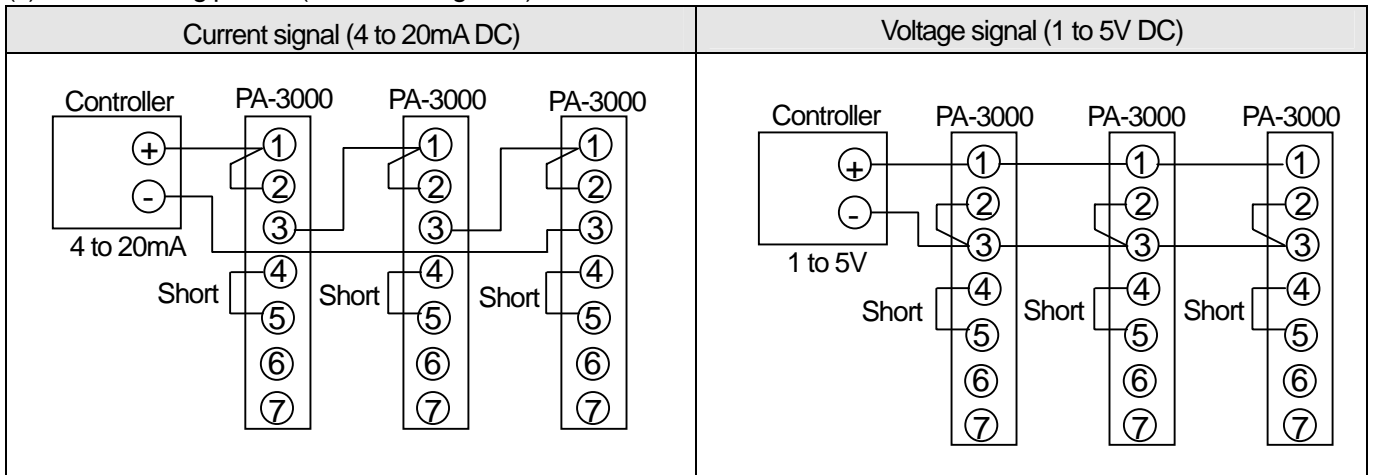

(6) 3 units running parallel with gradient setting units

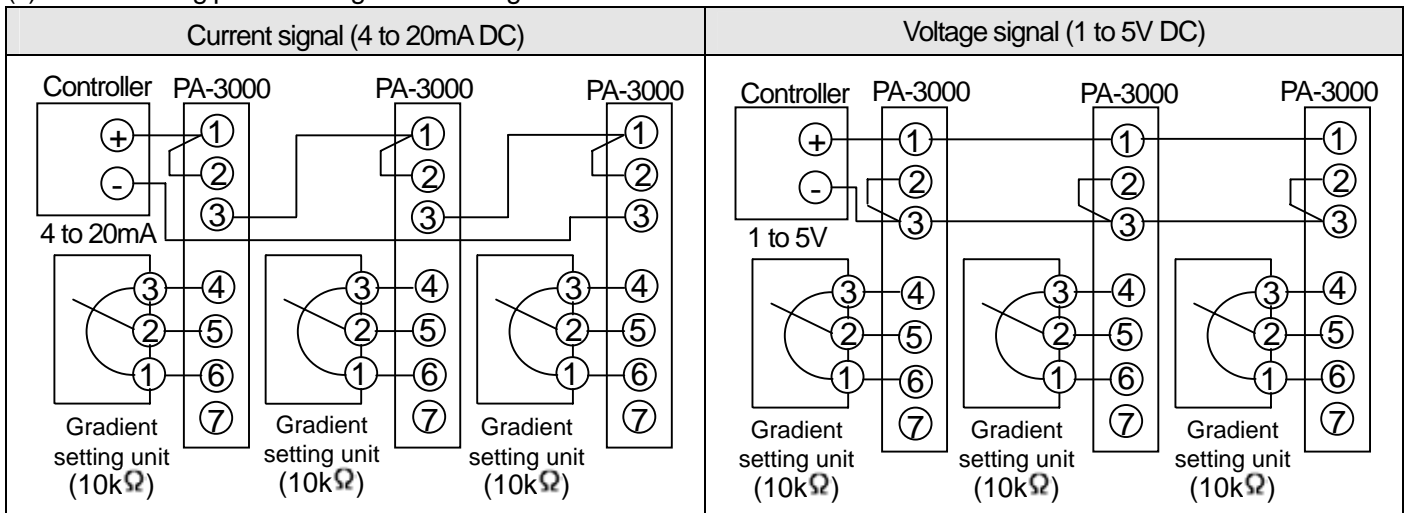

5.3.2 Contact input signal

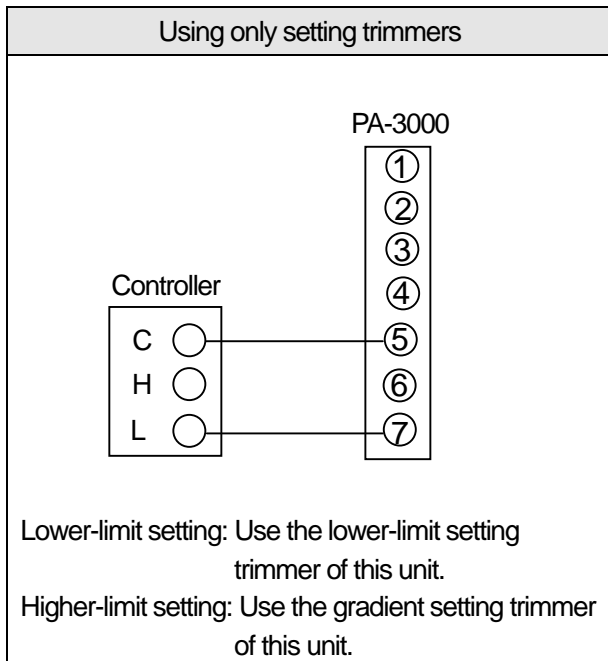
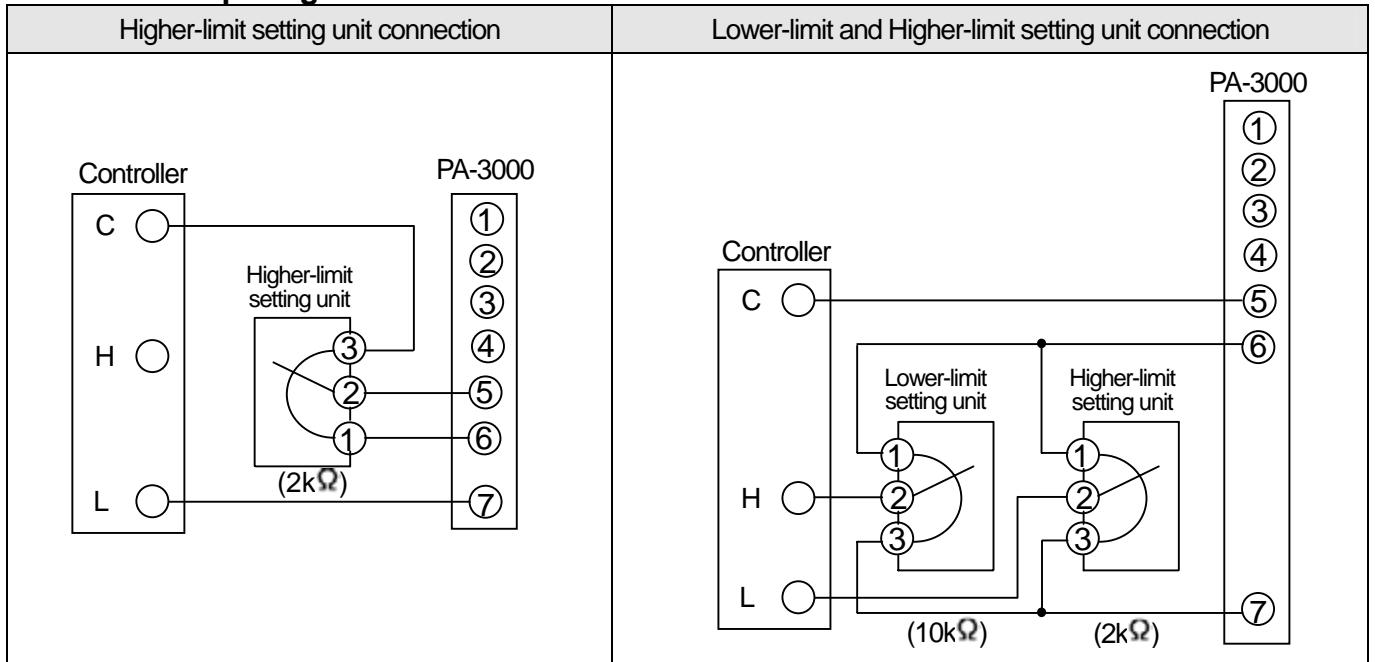

6. Operation

6.1 Checking before operation



Warning

Turn the power supply to the instrument off before checking. Working or touching the terminal with the power switched on may result in severe injury or death due to Electric shock.

- (1) Check the connections again.
- (2) Check the power voltage and the load capacity again.
- (3) Measure the insulation resistance with a 500V megger.
Short main circuit terminals U1 and U2 for the dielectric strength test.
- (4) This unit becomes hot due to being a self-cooling type.
Make sure to mount the unit with the UP mark (↕) facing upward so as not to interrupt the heat radiation effect.
If the unit is mounted in a direction other than specified, the interior becomes hot and could cause malfunction or other problems.
- (5) Check the control system selection again.

6.2 Operation

In the case of Auto running

- (1) Set the set value (SV) of a controller.
- (2) If an Auto/Manual selecting switch is connected, select it to "AUTO".
- (3) Set the gradient.
- (4) Make sure that a stable control is executed.
Change the parameters (PID constants in particular) of the controller and adjust the gradient setting suitably if the control is unstable.

In the case of Manual running

- (1) If an Auto/Manual selecting switch is connected, select it to "MANUAL".
- (2) Set a desired output manually.
- (3) Change the setting manually while monitoring the temperature.

7. Maintenance



Warning

Turn the power supply to the instrument off before checking, cleaning or maintenance work. Working or touching the terminal with the power switched on may result in severe injury or death due to Electric shock.

7.1 Daily check and maintenance

The checking and inspection of the following points are required to keep this unit running under the best conditions at all times.

Items	Contents
Fastening of bolts and screws on the terminal board	If the bolts for the main circuit terminals (U1, U2), in which a large current flows, are loose, they may become hot and cause wiring damage.
Cleaning	If the unit is mounted in a dusty place with conductive dust particles like iron powder, dust particles attached to the unit, this may cause failure or problems due to poor insulation. Remove dust particles attached using a cleaner.

7.2 Consumable parts



Caution

- To prevent an electric shock or fire, only Shinko or qualified service personnel may handle the inner assembly.
- To prevent an electric shock, fire or damage to the instrument, parts replacement may only be undertaken by Shinko or qualified service personnel.
- For replacing consumable parts or other parts, please contact the nearest sales agent of Shinko Technos Co., Ltd.

Parts	Exchange intervals	Working conditions
Control PCB	5 to 8 years	The higher the ambient temperature the shorter the life span. In addition, life span depends largely upon atmospheric conditions (kinds of gases, kinds and degree of dust particles, etc.)

8. Accessories sold separately

8.1 Setting unit

Model	Potentiometer	Scale board	Dial
External dimensions (unit: mm)			

8.2 Fuse unit (unit: mm)

Applicable current	20A	Applicable current	30 to 100A
Specification	Rapid fuse + holder	Specification	Rapid fuse + holder with cover

8.3 Rapid fuse

We can provide various types of rapid fuse.
Please consult us.

9. Troubleshooting

(1) Output continues

Problems	Presumed cause and solution
Is the load open?	Connect the load correctly.
Is the lower-limit set to 100%?	Set the lower-limit to be near 0% and monitor the condition.

If this unit is not restored to normal condition as a result of the above remedial measures, the thyristor element may be defective.

Please contact our main office or dealers.

(2) Output is not proportional to the control input.

Problems	Presumed cause and solution
Is the lower-limit set to be high?	Set the lower-limit to be near 0% and check the condition.
Is the gradient set to be low?	Set the gradient to be near 100% and check the condition.
Are the phases of the power supply and main circuit the same?	The phases should be the same. Refer to Section 5.2.
Is the power supply distorted?	If the power waveform is distorted, the output is not proportional to the input. Use a power supply without a distorted waveform and check the condition.

If this unit is not restored to normal condition as a result of the above remedial measures, the unit may be defective.

Please contact our main office or dealers.

(3) No output

Problems	Presumed cause and solution
Power indicator (green) does not light.	Power terminals (8 to 10) are not connected correctly.
	The main circuit and/or the load are not connected correctly.
Power indicator (green) does not go off.	The phase of the power supply and the main circuit are not the same. The phases should be the same. Refer to Section 5.2.
	Gradient is set to 0%. Set it to near 100% and check the condition.
	Input connections (1 to 7 terminals) are not correct.
	Input signal is abnormal. Apply normal input signal.
Power indicator (green) is flashing.	Power supply is distorted. Refer to (2) above.

If this unit is not restored to normal condition as a result of the above remedial measures, the unit may be defective.

For all other malfunctions, please contact our main office or dealers.

10. General specifications

Phase	Single phase
Rated current	20, 30, 40, 50, 75, 100AAC
Input signal	4 to 20mA DC, 1 to 5V DC or ON/OFF contact signal
Input resistance	100 Ω (4 to 20mA DC), 25k Ω (1 to 5V DC)
Rated voltage	100 to 120V AC, 200 to 240V AC (100V system and 200V system are selectable by terminals)
Allowable voltage fluctuation range	-10 to +10% of the rated voltage
Rated frequency	50/60Hz (automatic selection)
Allowable frequency fluctuation	± 2 Hz (operation guarantee), ± 1 Hz (performance guarantee) of the rated frequency
Output range	0 to 98% of the rated voltage
Minimum load current	0.5A (at 98% output)
Applicable load	Resistive load, inductive load (transformer primary control: Phase-angle firing system only Magnetic flux density 1.25T or less)
Control system	Phase-angle firing system without feedback
	Zero-cross firing system without feedback
	Selectable by DIP switch
Output setting range	Gradient setting: 0 to 100% of the output range (Setting trimmer built-in)
	Lower-limit setting: 0 to 100% of the output range (Setting trimmer built-in)
Other functions	Soft start, soft up-down (1 to 20 seconds variable), Soft start at recovery from momentary interruption
Operating temperature range	-15 to 55 $^{\circ}$ C (operation guarantee), 0 to 40 $^{\circ}$ C (performance guarantee)
Operating humidity range	30 to 90%RH (Non condensing)
Insulation resistance	Between main circuit terminals and case, between power terminals and case: 20M Ω or more, at 500V DC
Dielectric strength	Between main circuit terminals and case: 2000V AC for 1 minute

SHINKO TECHNOS CO.,LTD.
OVERSEAS DIVISION

Reg. Office: 2-5-1, Senbahigashi, Minoo, Osaka, Japan

URL : <http://www.shinko-technos.co.jp>

E-mail : overseas@shinko-technos.co.jp

Tel : 81-72-727-6100

Fax: 81-72-727-7006