

MULTI-DROP COMMUNICATION TYPE  
TEMPERATURE CONTROL UNIT

# NCL-13A

INSTRUCTION MANUAL

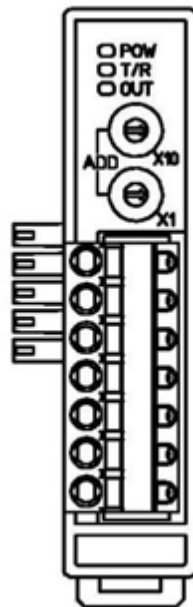

***Shinko***

# Preface

Thank you for the purchase of Multi-drop Communication type Temperature Control Unit NCL-13A. This manual contains instructions for the mounting, functions, operations and notes when operating the NCL-13A. To prevent accidents arising from the misuse of this control unit, please ensure the operator receives this manual.

## Notes

- This instrument should be used in accordance with the specifications described in the manual. If it is not used according to the specifications, it may malfunction or cause fire.
- Be sure to follow the warnings, cautions and notices. If they are not observed, serious injury or malfunction may occur.
- Specifications, external appearance of the NCL-13A and the contents of this instruction manual are subject to change without notice.
- Care has been taken to assure that the contents of this instruction manual are correct, but if there are any doubts, mistakes or questions, please inform our sales department.
- This instrument is designed to be installed on a DIN rail. If it is not, measures must be taken to ensure that the operator does not touch power terminals or other high voltage sections.
- Any unauthorized transfer or copying of this document, in part or in whole, is prohibited.
- Shinko Technos CO., LTD. is not liable for any damages or secondary damages incurred as a result of using this product, including any indirect damages.

## SAFETY PRECAUTIONS (Be sure to read these precautions before using our products.)

The safety precautions are classified into categories: "Warning" and "Caution".

Depending on circumstances, procedures indicated by  Caution may be linked to serious results, so be sure to follow the directions for usage.



### Warning

Procedures which may lead to dangerous conditions and cause death or serious injury, if not carried out properly.



### Caution

Procedures which may lead to dangerous conditions and cause superficial to medium injury or physical damage or may degrade or damage the product, if not carried out properly.



### Warning

- To prevent an electric shock or fire, only Shinko or qualified service personnel may handle the inner assembly.
- To prevent an electric shock, fire or damage to instrument, parts replacement may only be undertaken by Shinko or qualified service personnel.



## SAFETY PRECAUTIONS

- To ensure safe and correct use, thoroughly read and understand this manual before using this instrument.
- This instrument is intended to be used for industrial machinery, machine tools and measuring equipment. Verify correct usage after consulting purpose of use with our agency or main office (Never use this instrument for medical purposes with which human lives are involved.)
- External protection devices such as protection equipment against excessive temperature rise, etc. must be installed, as malfunction of this product could result in serious damage to the system or injury to personnel. Also proper periodic maintenance is required.
- This instrument must be used under the conditions and environment described in this manual  
Shinko Technos Co., Ltd. does not accept liability for any injury, loss of life or damage occurring due to the instrument being used under conditions not otherwise stated in this manual.

### Caution with respect to Export Trade Control Ordinance

To avoid this instrument from being used as a component in, or as being utilized in the manufacture of weapons of mass destruction (i.e. military applications, military equipment, etc.), please investigate the end users and the final use of this instrument. In the case of resale, ensure that this instrument is not illegally exported.

# 1. Installation precautions



## Caution

This unit is intended to be used under the following environmental conditions (IEC61010-1): Overvoltage category II, Pollution degree 2

Ensure the mounting location corresponds to the following conditions:

- A minimum of dust, and an absence of corrosive gases
- No flammable, explosive gases
- No mechanical vibrations or shocks
- No exposure to direct sunlight, an ambient temperature of 0 to 50°C (32 to 122°F) that does not change rapidly
- An ambient non-condensing humidity of 35 to 85%RH
- No large capacity electromagnetic switches or cables through which large current flows
- No water, oil or chemicals or where the vapors of these substances can come into direct contact with the unit

**Note:** Do not install this unit near flammable material even though the case of this unit is made of flame resistant resin.

Avoid setting this unit directly on flammable material.

# 2. Wiring precautions



## Caution

- Do not leave wire chips in the unit, because they could cause fire, malfunction or trouble.
- When wiring terminals of the NCL-13A, use ferrules with an insulation sleeve applicable to the connecting plugs.
- A screw type plug for lines (sold separately) is required for wiring of power and communication lines. Use the ferrules with an insulation sleeve in which an M2 screw fits.
- Tighten the terminal screw within the specified torque. If excessive force is applied to the screw when tightening, the screw or case may be damaged.
- Do not apply a commercial power source to the sensor connected to the NCL-13A nor allow the power source to come into contact with the sensor, as the input circuit may be burnt out.
- Use a thermocouple, compensating lead wire and RTD (3-wire) according to the input of this unit.
- With the relay contact output type, externally use a relay according to the capacity of the load to protect the built-in relay contact.
- Keep the input wire (TC, compensating lead wire, etc.), power line and load wire away from one another.
- To prevent the unit from harmful effects of unexpected level noise, it is recommended that a surge absorber be installed between the electromagnetic switch coils.
- Externally install a protecting circuit in case there is unexpected trouble due to the environment, aging, etc.
- This unit has neither a built-in power switch nor a fuse. Therefore, it is necessary to install them in the circuit near the unit externally.
- The supply voltage of this unit is 24V DC. Do not confuse the polarity.

## 3. Running and maintenance precautions



### Warning

- It is recommended that the PID auto-tuning be performed on the trial run.
- Do not touch live terminals. This may cause electric shock or problems in operation.
- Turn the power supply to the instrument OFF before retightening the terminal and cleaning.  
Working or touching the terminal with the power switched ON may result in severe injury or death due to Electric Shock.
- Use a soft, dry cloth when cleaning the unit.  
(Alcohol based substances may cause tarnishing or defacement of the unit)
- As the display section is vulnerable, do not strike or scratch it with a hard object.

## --- CONTENTS ---

<b>1. System configuration</b> .....	6
<b>2. Model name</b>	
2.1 Model name .....	7
2.2 How to read the model name label .....	7
<b>3. Name and functions of the sections</b> .....	8
<b>4. Communication parameter setting</b>	
4.1 Instrument number setting .....	9
4.2 Communication speed and protocol selection .....	10
4.2.1 Communication speed selection .....	10
4.2.2 Communication protocol selection .....	10
<b>5. Mounting</b>	
5.1 Site selection .....	11
5.2 External dimensions .....	11
5.3 Mounting to DIN rail .....	12
5.4 Removal from DIN rail .....	15
<b>6. Wiring</b> .....	16
6.1 Terminal arrangement .....	17
6.2 Recommended ferrules .....	17
6.3 Connecting power and communication line to the screw type plug for the line (Model: Terminal block ATB-001-1), sold separately) .....	18
6.4 Connecting input, control output (OUT1), and event output wires to the spring type plug .....	18
6.5 Connecting wire from the CT with CT1, CT2 input connectors .....	18
6.6 Wiring example .....	20

<b>7. Communication procedure</b>	21
<b>8. Communication protocol</b>	
8.1 Shinko protocol	22
8.1.1 Transmission mode	22
8.1.2 Command configuration	22
8.1.3 Checksum calculation	24
8.1.4 Contents of the command	25
8.1.5 Command example	25
8.2 Modbus protocol	26
8.2.1 Transmission mode	26
8.2.2 ASCII mode	26
8.2.3 RTU mode	29
<b>9. Communication command table</b>	32
<b>10. Running</b>	
10.1 Setup	37
10.2 Start running	42
10.3 Output MV reading	43
10.4 Control Allowed/Prohibited selection	43
10.5 Auto-tuning Perform/Cancel	44
<b>11. Control action explanation</b>	
11.1 P, I, D and ARW	46
11.2 Control output (OUT1) action	47
11.3 Control output (OUT1) ON/OFF action	48
11.4 Heating/Cooling control action (DC option)	49
11.5 Alarm 1, Alarm 2, Alarm 3 and Alarm 4 actions	52
11.6 Heater burnout alarm/Actuator short circuit alarm (W, W3 option)	53
<b>12. Attached functions</b>	
12.1 Self diagnosis	54
12.2 Automatic cold junction temperature compensation	54
12.3 Burnout	54
12.4 Output status selection when Input abnormal	54
12.5 Input abnormality	54
12.6 Sensor correction	55
12.7 PV filter	55
12.8 Power failure countermeasure	55
12.9 Non-volatile memory data saving selection	55
<b>13. Specifications</b>	
13.1 Standard specifications	55
13.2 Optional specifications	60
<b>14. Troubleshooting</b>	
14.1 Communication	62
14.2 Control	62
14.3 PV	63



## 2. Model name

### 2.1 Model name

NCL-13A-□/□ □ □ □ □		Series name: NCL-13A (W17.5 x H75 x D85mm)	
Alarm	A	Alarm 1 output, Alarm 2, Alarm 3, Alarm 4 (*1)	
Control output (OUT1)	R	Relay contact: 1a	
	S	Non-contact voltage (for SSR drive): 12 <sup>+</sup> <sub>0</sub> <sup>-2</sup> V DC	
	A	DC current: 4 to 20mA DC	
	C	Open collector: 0.1A 24V DC (maximum)	
Input	M	Multi-range (*2)	
Option	DC	Heating/Cooling control output	Open collector output (OUT2)
	W/W3	Heater burnout alarm/Actuator short circuit alarm (W: Shingle phase, W3: 3-phase)	

\*1: An alarm action (9 types and No alarm action) and Alarm 1 output Energized/Deenergized can be selected from the host computer through communication unction.

For Alarm 2, Alarm 3 and Alarm 4, the output and Energized/Deenergized selection are not available. By reading status flags in serial communication, their alarm status can be assessed.

\*2: Thermocouple, RTD, DC current or DC voltage can be selected from the host computer through communication function.

For DC current input, 50Ω shunt resistor (RES-S03-050, sold separately) must be installed between input terminals.

### 2.2 How to read the model name label



## Warning

Turn the power supply to the instrument off before confirming the model name labels.

Working or touching the terminal with the power switched on may result in severe injury or death due to Electric Shock.

Model name labels are attached to the case and the inner assembly.

(e.g.) Case

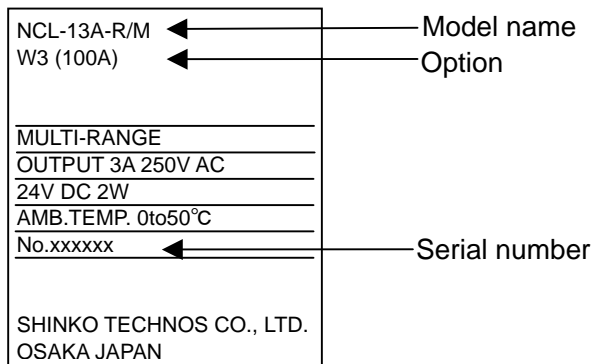

(Fig. 2.2-1)

(e.g.) Internal assembly

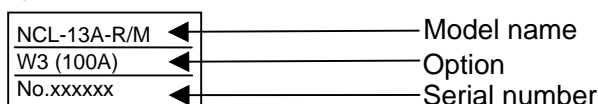

(Fig. 2.2-2)

### 3. Name and functions of the sections

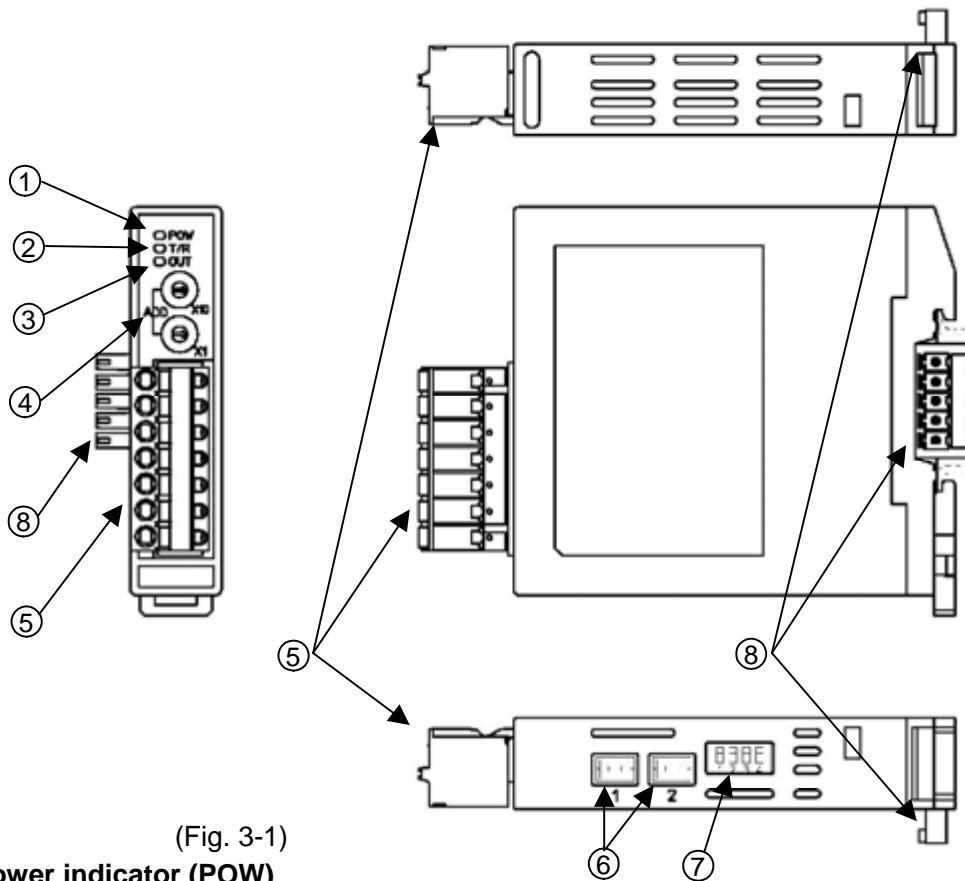

(Fig. 3-1)

- ① **Power indicator (POW)**  
A green LED lights up when the power to the unit is turned on.  
A green LED flashes if any alarm (temperature alarm, Heater burnout/Actuator short circuit alarm or Loop break alarm) occurs.
- ② **Communication indicator (T/R)**  
A yellow LED lights up during serial communication TX.
- ③ **Control output indicator (OUT)**  
A green LED lights up when control output (OUT1) is on.  
For DC current output, a green LED flashes corresponding to the MV (manipulated variable).
- ④ **Rotary switch for instrument number setting**  
Sets the instrument number of the NCL-13A.
- ⑤ **Spring type plug:** Plug for input, control output (OUT1) and event output.
- ⑥ **CT1, CT2 input connector:** Connector for CT input of Heater burnout/Actuator short circuit alarm (W, W3 option).
- ⑦ **DIP switch for selecting communication speed and communication protocol**  
Selects communication speed and communication protocol of the NCL-13A.
- ⑧ **Bus plug:**  
Plug for lines (power bus, communication bus).  
When connecting multiple units, the bus plug can connect to another bus plug.

## 4. Communication parameter setting

This chapter describes how to set or select the instrument number, communication speed and communication protocol.



### Warning

Set communication parameters after turning the power to the unit OFF.  
Setting communication parameters with the power switched on may result in severe injury or death due to Electric Shock.



### Caution

When the power to the unit is turned on, this unit reads the contents set by the rotary switch and DIP switch.  
If any setting is changed after the power-on, turn the power off and on again.

#### 4.1 Instrument number setting

When communicating by connecting multiple NCL-13A units, set the instrument number of each unit by means of the rotary switch. (Default value: 0 x10, 0 x 1)

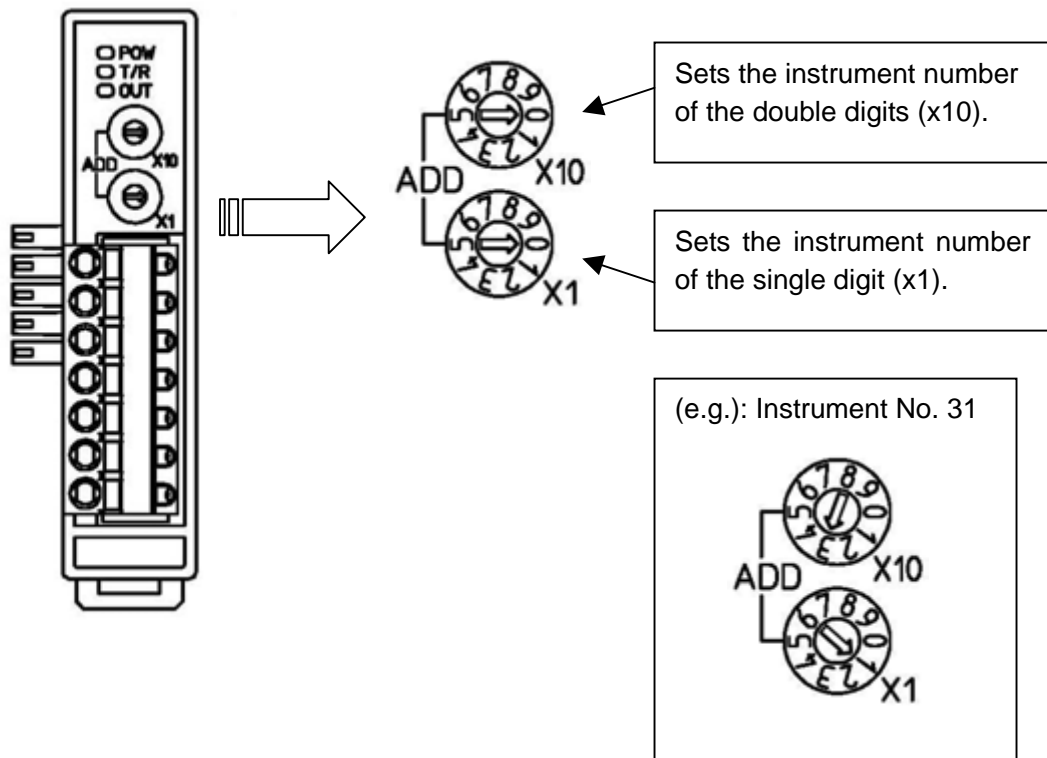

(Fig. 4.1-1)

## 4.2 Communication speed and protocol selection

Select the communication speed and protocol with the DIP switch.

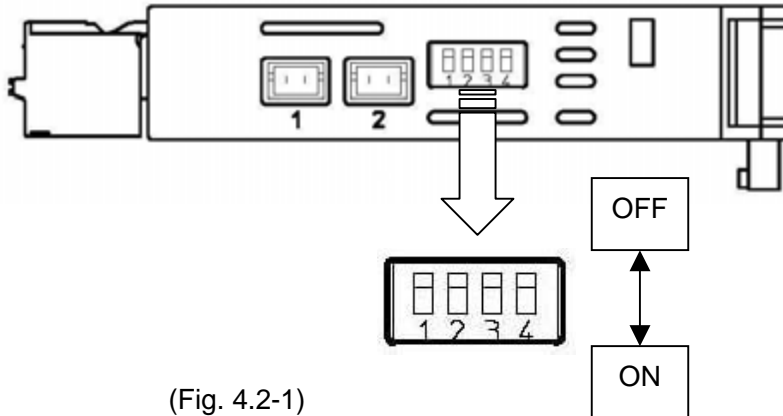

(Fig. 4.2-1)

### 4.2.1 Communication speed selection

Select the communication speed with DIP switch 1 and 2 to be equal to that of the host computer. (Default value: 9600bps)

(Table 4.2.1-1)

DIP switch No.		Communication speed
1	2	
OFF	OFF	9600bps
ON	OFF	4800bps
OFF	ON	19200bps

### 4.2.2 Communication protocol selection

Select the communication protocol with DIP switch 3 and 4.

(Default value: Shinko protocol)

(Table 4.2.2-1)

DIP switch No.		Communication protocol	Start bit	Data length	Stop bit	Parity bit
3	4					
OFF	OFF	Shinko protocol	1	7	1	Yes (Even)
ON	OFF	Modbus ASCII	1	7	1	Yes (Even)
OFF	ON	Modbus RTU	1	8	1	No parity

# 5. Mounting

## 5.1 Site selection

This unit is intended to be used under the following environmental conditions (IEC61010-1): Overvoltage category II, Pollution degree 2

Ensure the mounting location corresponds to the following conditions:

- A minimum of dust, and an absence of corrosive gases
- No flammable, explosive gases
- No mechanical vibrations or shocks
- No exposure to direct sunlight, an ambient temperature of 0 to 50°C (32 to 122°F) that does not change rapidly
- An ambient non-condensing humidity of 35 to 85%RH
- No large capacity electromagnetic switches or cables through which large current flows
- No water, oil or chemicals or where the vapors of these substances can come into direct contact with this unit

## 5.2 External dimensions

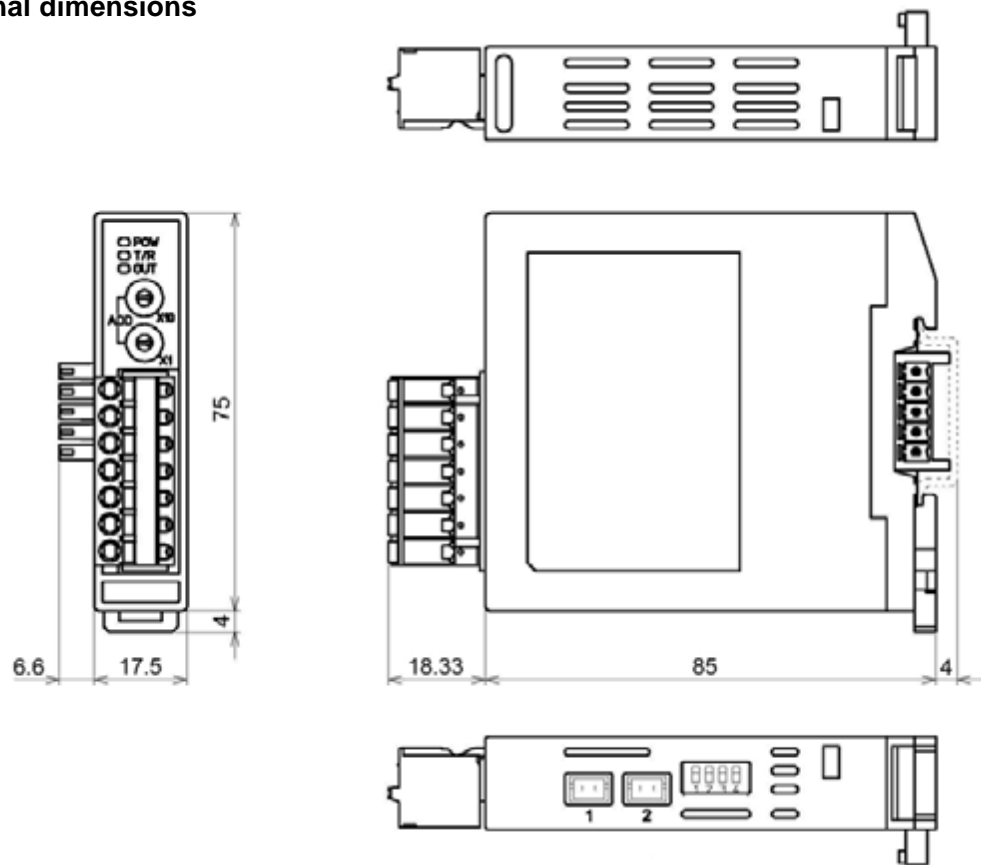

(Fig. 5.2-1)

### 5.3 Mounting to DIN rail



## Notice

- Mount the DIN rail laterally.
- The following shows DIN rail corresponding to the NCL-13A.

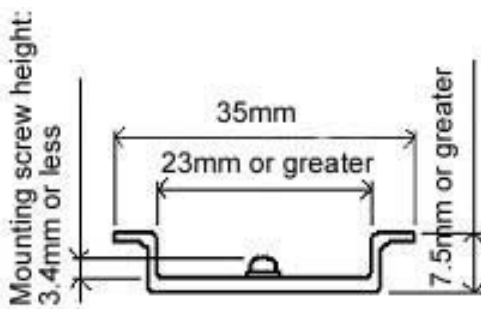

Width : 35mm  
Height : 7.5mm or more  
Groove width : 23mm or more  
DIN rail mounting screw height:  
3.4mm or less (At a DIN rail height  
of 7.5mm)

(Fig. 5.3-1)

- If the DIN rail is mounted in a position susceptible to vibration or shock, be sure to use End plates (AEP-001-1, sold separately) at both ends of the unit.
- Do not confuse the top and bottom of this unit.
- When mounting to or removing the unit from the DIN rail, the units must be slanted a little.  
Therefore do not mount any other instruments within 50mm of space at the left side, upside and down side from the unit, considering radiation.

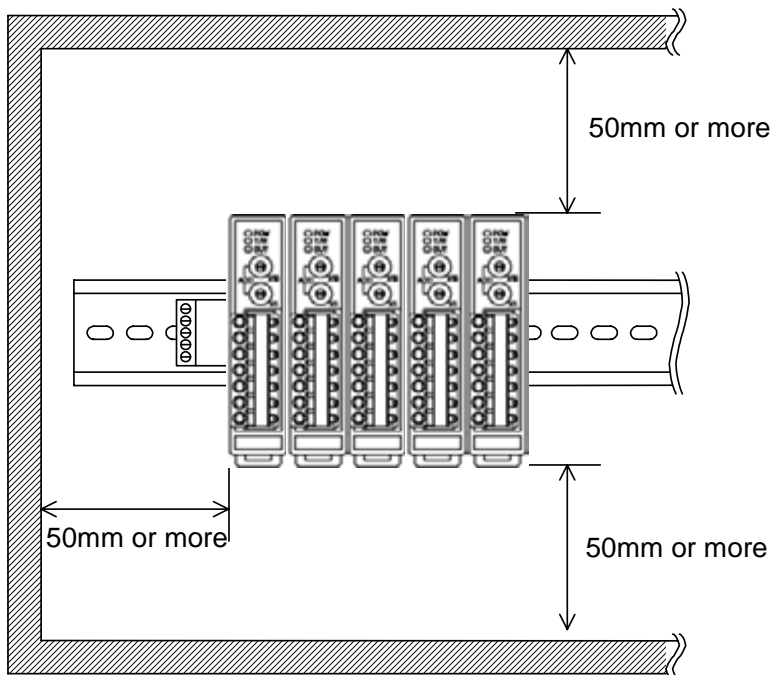

(Fig. 5.3-2)

Mount the unit by following the procedures below.

(1) Remove the bus plug from the unit.

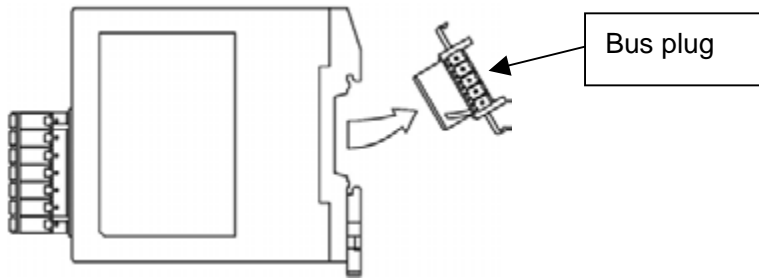

(Fig. 5.3-3)

(2) Mount the removed bus plug to the DIN rail.

Hook the top and bottom claws of the bus plug and fit them in the DIN rail with “click” sound.

When mounting plural units, link the bus plugs as shown in (Fig. 5.3-4).

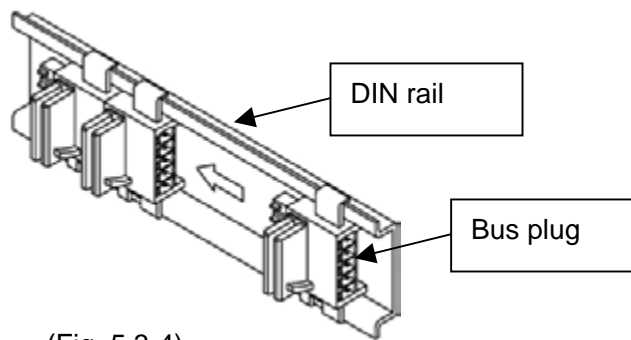

(Fig. 5.3-4)

(3) Pull the lock lever of the unit down (①), hook the unit to the DIN rail at an angle of approx. 20 degrees upward (②) and mount it (③).

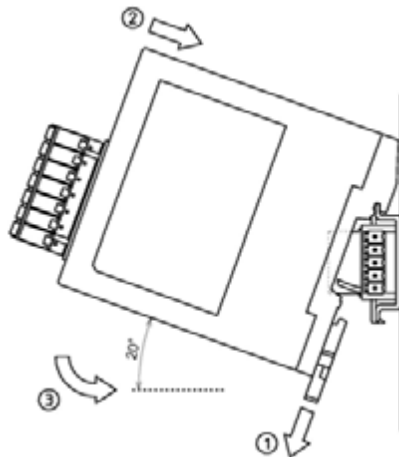

(Fig. 5.3-5)

(4) Push the lock lever of the unit up until a clicking sound is heard (④).

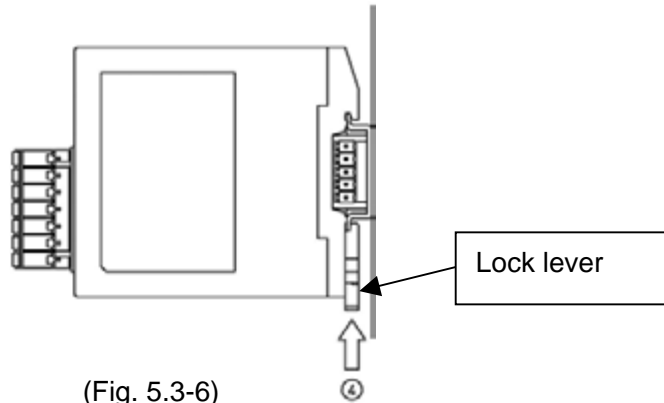

## Notice

Check whether the NCL-33A is securely fixed on the DIN rail.

(5) Mount the screw type plug for lines (Model: Terminal block ATB-001-1, sold separately) to the bus plug.  
The screw type plug (Model: Terminal block ATB-001-1, sold separately) can also be mounted to the bus plug after wiring the power and communication lines.

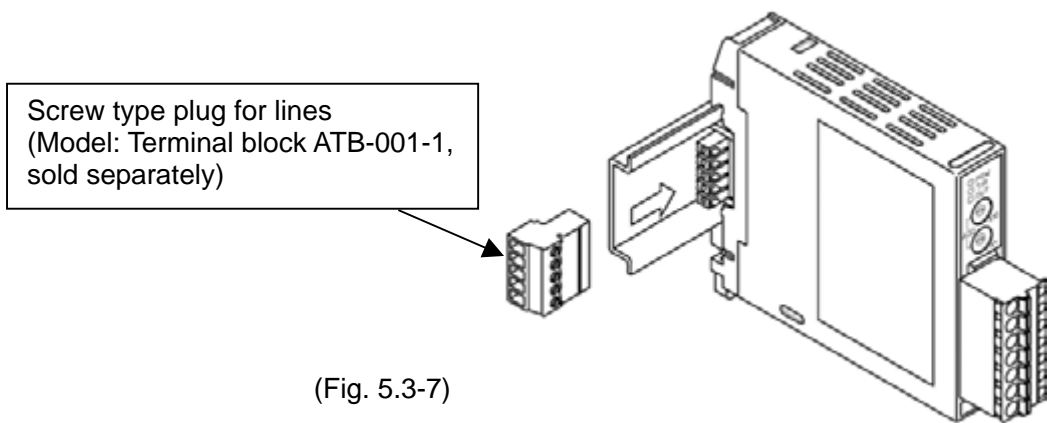

#### 5.4 Removal from DIN rail

- (1) Pull the lock lever down (①), and remove the unit from the DIN rail as lifting the unit a little (②). The bus plug still remains on the DIN rail.

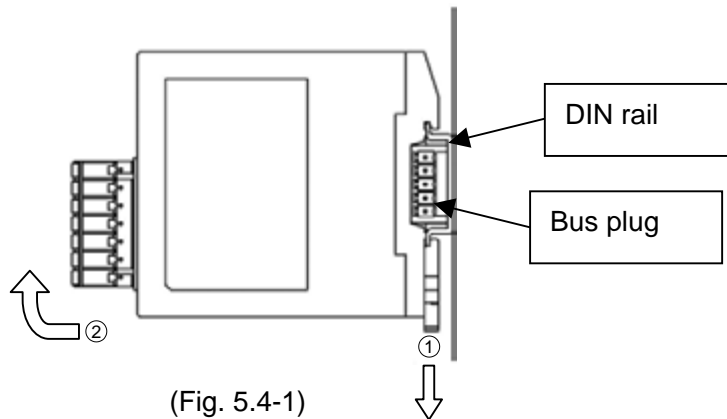

- (2) When multiple bus plugs are mounted, separate the linking sections first. By inserting the flat-blade screwdriver into the slit, push the plug aside using leverage. (Fig. 5.4-2), (Fig. 5.4-3①)  
Remove the bus plug from the DIN rail by lifting the upper claw of the plug a little. (Fig. 5.4-3②)

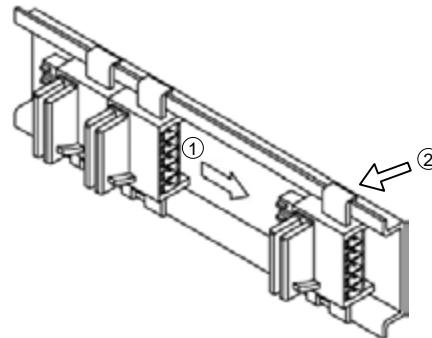
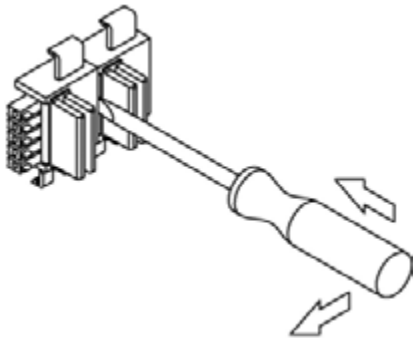

### Notice

When separating bus plugs at the linking part, do not use excessive force.

## 6. Wiring



### Warning

Turn the power supply to the unit off before wiring.  
Working or touching the terminal with the power switched on may result in severe injury or death due to Electric Shock.



### Caution

- Do not leave wire chips in the unit, because they could cause fire, malfunction or trouble.
- When wiring terminals of the NCL-13A, use ferrules with an insulation sleeve applicable to the connecting plugs.
- A screw type plug for lines (Model: Terminal block ATB-001-1, sold separately) is required for wiring of power and communication lines. Use the ferrules with an insulation sleeve in which an M2 screw fits.
- Tighten the terminal screw within the specified torque. If excessive force is applied to the screw when tightening, the screw or case may be damaged.
- Do not apply a commercial power source to the sensor connected to the NCL-13A nor allow the power source to come into contact with the sensor, as the input circuit may be burnt out.
- Use a thermocouple, compensating lead wire and RTD (3-wire) in accordance with the input of this unit.
- With the relay contact output type, externally use a relay according to the capacity of the load to protect the built-in relay contact.
- Keep the input wire (TC, compensating lead wire, etc.), power line and load wire away from one another.
- To prevent the unit from harmful effects of unexpected level noise, it is recommended that a surge absorber be installed between the electromagnetic switch coils.
- Externally install a protecting circuit in case there is unexpected trouble due to the environment, aging, etc.
- This unit has neither a built-in power switch nor a fuse. Therefore, it is necessary to install them in the circuit near the unit externally.
- The supply voltage of this unit is 24V DC. Do not confuse the polarity.

## 6.1 Terminal arrangement

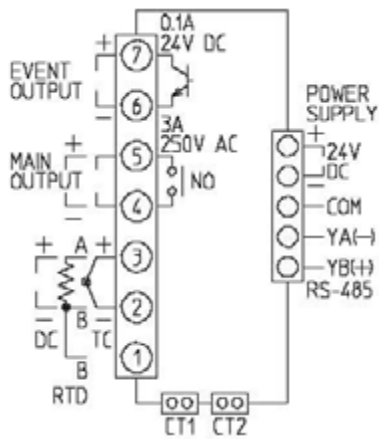

(Fig. 6.1-1)

### Bus plug, Screw type plug for lines

(Model: Terminal block ATB-001-1, sold separately)

- POWER SUPPLY (24V DC) : Power line terminals
- RS-485 [(YA (-), YB (+), COM)]: Communication line terminals

### Spring type plug

- EVENT OUTPUT: Event output terminals (\*)
- MAIN OUTPUT : Control output (OUT1) terminals
- TC, RTD, DC : Input terminals

(\*) Alarm 1 (Utilizes common output terminals with Heater burnout/Actuator short circuit alarm and Loop break alarm) or Cooling control output (OUT2)

### CT1, CT2 input connector

- CT1: CT input connector (W, W3 option)
- CT2: CT input connector (W3 option)

## 6.2 Recommended ferrules

When using ferrules, use the following recommended ferrules with an insulation sleeve and crimping pliers made by Phoenix Contact GMBH & CO. (Table 6.2-1, Table 6.2-2)

(Table 6.2-1)

**Spring type plug [input, control output (OUT1), event output terminals]**  
terminal number from ① to ⑦

Ferrules with insulation sleeve	Conductor cross sections	Crimping pliers
AI 0.25-6 BU	0.2 to 0.25mm <sup>2</sup>	ZA3 CRIMPFOX UD 6
AI 0.34-8 TQ	0.25 to 0.34mm <sup>2</sup>	
AI 0.5-8 WH	0.34 to 0.5mm <sup>2</sup>	
AI 0.75-8 GY	0.5 to 0.75mm <sup>2</sup>	
AI 1.0-8 RD	0.75 to 1.0mm <sup>2</sup>	
AI 1.5-8 BK	1.0 to 1.5mm <sup>2</sup>	
AI 2.5-8 BU	1.5 to 2.5mm <sup>2</sup>	

For DC current input, connect a shunt resistor (50Ω, RES-S03-050, sold separately) and input wires (+, -) with the provided ferrules for 2 wires.

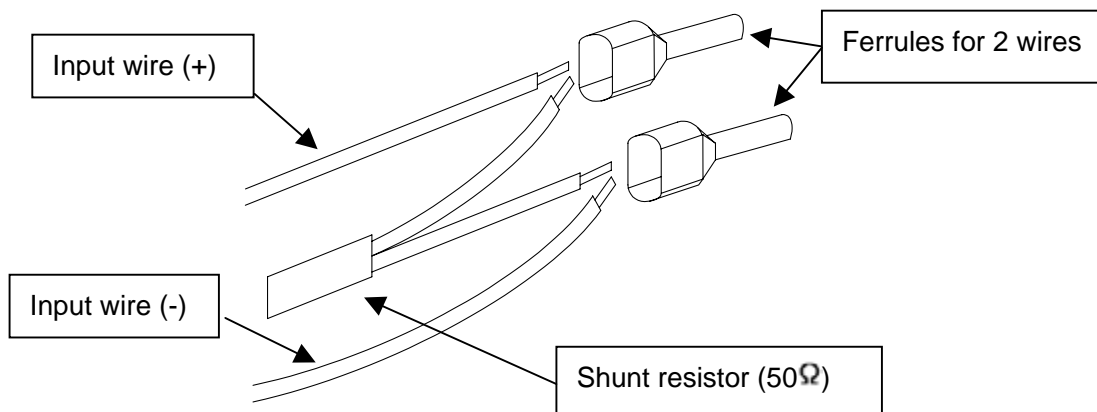

(Fig. 6.2-1)

(Table 6.2-2)

**Screw type plug for lines** (Model: Terminal block ATB-001-1, sold separately)  
**M2 screw (power and communication line terminals)**

Ferrules with insulation sleeve	Conductor cross sections	Tightening torque	Crimping pliers
Al 0.25-6 BU	0.2 to 0.25mm <sup>2</sup>	0.22 to 0.25N•m	ZA3 CRIMPFOX UD 6
Al 0.34-6 TQ	0.25 to 0.34mm <sup>2</sup>		
Al 0.5-6 WH	0.34 to 0.5mm <sup>2</sup>		
Al 0.75-6 GY	0.5 to 0.75mm <sup>2</sup>		
Al 1-6 RD	0.75 to 1.0mm <sup>2</sup>		
Al 1.5-6 BK	1.0 to 1.5mm <sup>2</sup>		

**6.3 Connecting power and communication lines to the screw type plug for lines**

(Model: Terminal block ATB-001-1, sold separately)

M2 screws are used for the screw type plug for lines (Model: Terminal block ATB-001-1, sold separately).

Tighten the terminal screws within the specified torque.

**6.4 Connecting input, control output (OUT1) and event output wires to the spring type plug**

Use a flat-blade screwdriver for wiring the spring type plug.

As pressing the lever (orange color) with a flat-blade screwdriver, insert the wire.

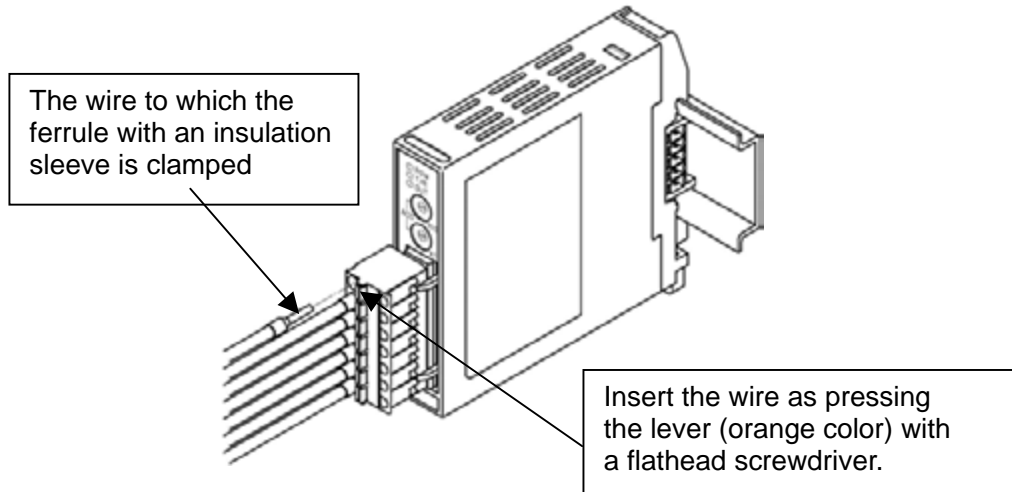

(Fig 6.4-1)

**6.5 Connecting wire from the CT with CT1, CT2 input connectors.**

For the W option, CT1 is provided, and for the W3 option, CT1 and CT2 are provided. Pass the heater wire into the CT hole, and solder wires of the wire harness provided.

(Fig. 6.5-1)

Insert the wire harness into the CT1 input connector. (Fig. 6.5-2)

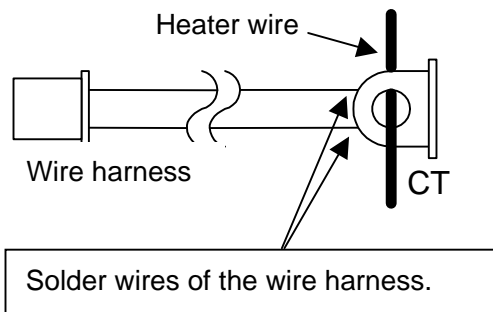

(Fig. 6.5-1)

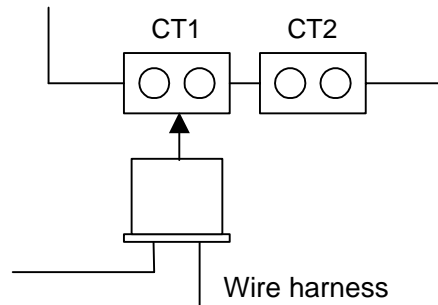

(Fig. 6.5-2)

For 3-phase, pass 2 wires out of R, S and T wires into the CT hole. (Fig. 6.5-3)  
Insert the wire harness into the CT1 and CT2 input connectors.

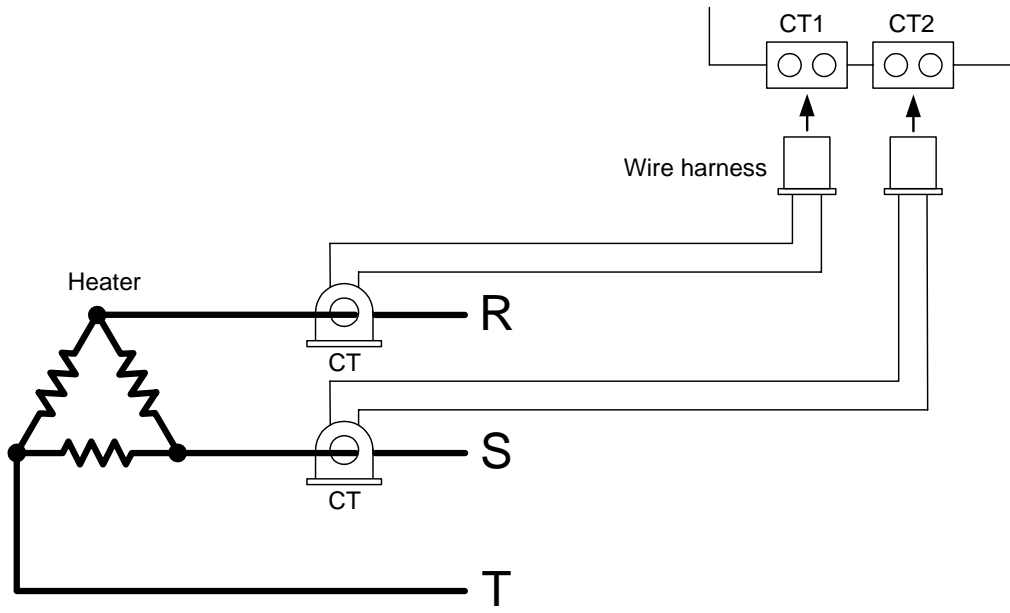

(Fig. 6.5-3)

## 6.6 Wiring example

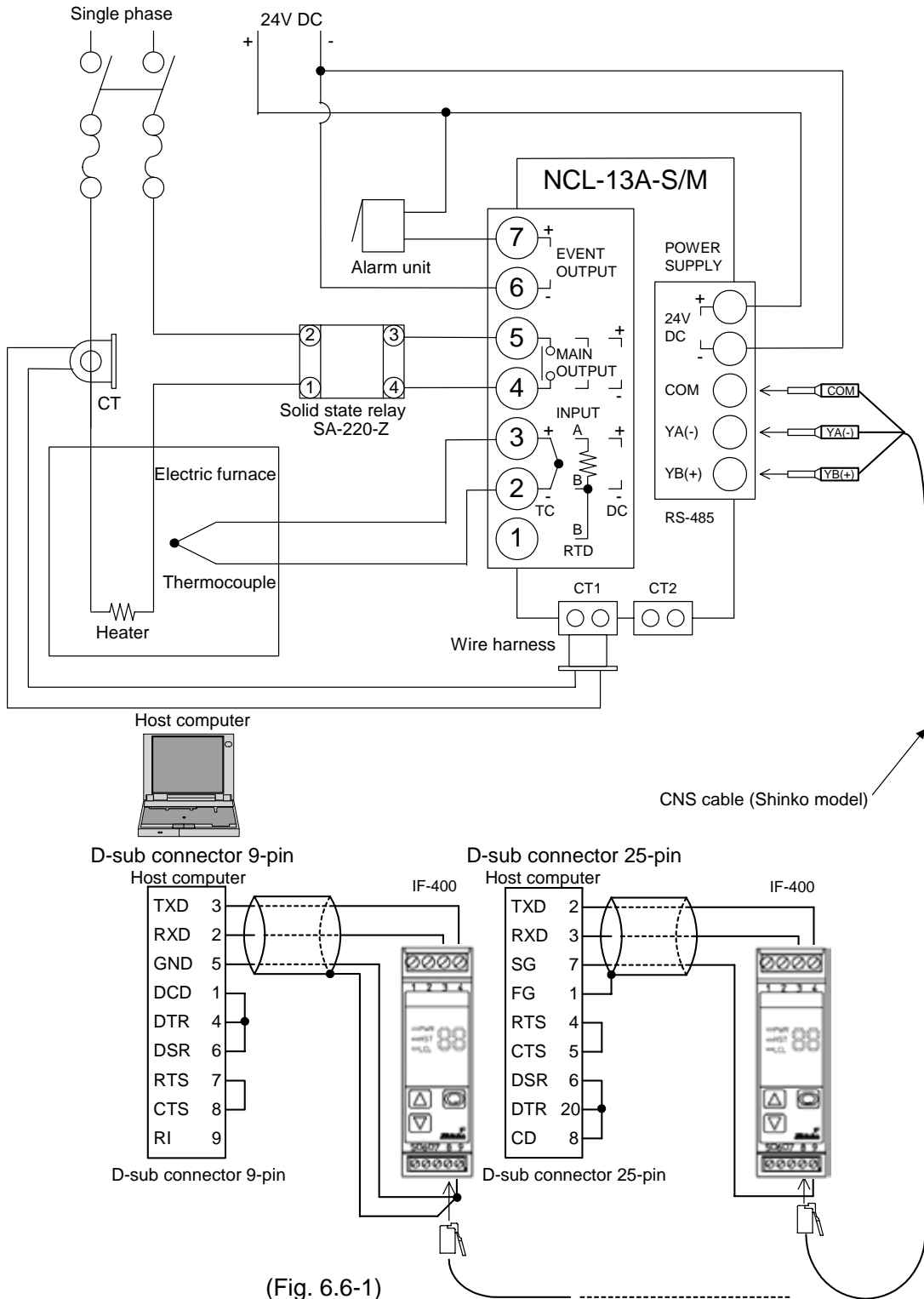

### Shield

Connect only one side of the shield to the FG or GND terminal so that current cannot flow through the shield. If both sides of the shield are connected to the FG or GND terminal, the circuit will be closed between the shield and the ground. As a result, current will run through the shield and this may cause noise. Be sure to ground FG and GND terminals.

# 7. Communication procedure

Communication starts with command transmission from the host computer (hereafter Master) and ends with the response of the NCL-13A (hereafter Slave).

- **Response with data**

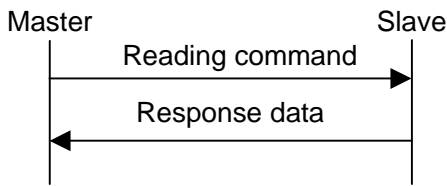

When the master sends the reading command, the slave responds with the corresponding setting value or current status.

- **Acknowledgement**

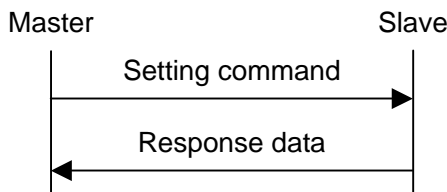

When the master sends the setting command, the slave responds by sending a acknowledgement after the processing is terminated.

- **Negative acknowledgement**

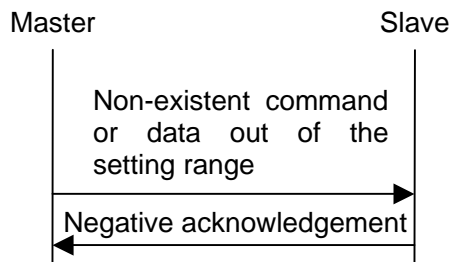

When the master sends non-existent command or a value outside the setting range, the slave returns a negative acknowledgement.

- **No response**

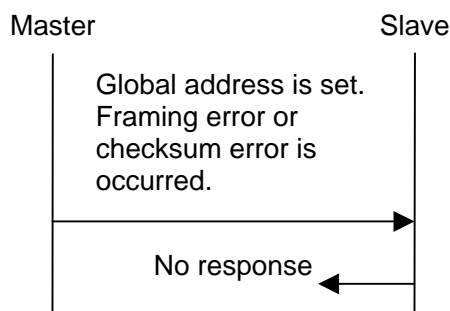

The slave will not respond to the master when global address is set, or when there is a framing error or checksum error (for Shinko protocol), or when LRC discrepancy (for Modbus protocol ASCII mode) or CRC discrepancy (for Modbus protocol RTU mode) is detected.

(Fig. 7-1)

## Communication timing of the RS-485 (C5 option)

### Slave side

When the slave starts transmission through the RS-485 communication line, the slave is arranged so as to provide an idle status (mark status) **transmission period of 1 or more characters** before sending the response to ensure the synchronization on the receiving side.

The slave is arranged so as to disconnect the transmitter from the communication line **within a 1 character transmission period** after sending the response.

### Master side (Notice on programming)

Set the program so that the master can disconnect the transmitter from the communication line **within a 1 character transmission period** after sending the command in preparation for reception of the response from the slave.

To avoid the collision of transmissions between the master and the slave, send the next command after carefully checking that the master received the response.

## 8. Communication protocol

### 8.1 Shinko protocol

#### 8.1.1 Transmission mode

Shinko protocol is composed of ASCII codes.

Hexadecimal (0 to 9, A to F), which is divided into high order (4-bit) and low order (4-bit) out of 8-bit binary data in command is transmitted as ASCII characters.

Data format      Start bit        : 1 bit  
                          Data bit        : 7 bits  
                          Parity            : Even  
                          Stop bit        : 1 bit  
                          Error detection: Checksum

#### 8.1.2 Command configuration

All commands are composed of ASCII. The data (setting value, decimal number) is represented by hexadecimal figures, and ASCII code is used.

The negative numbers are represented by 2's complement.

##### (1) Setting command

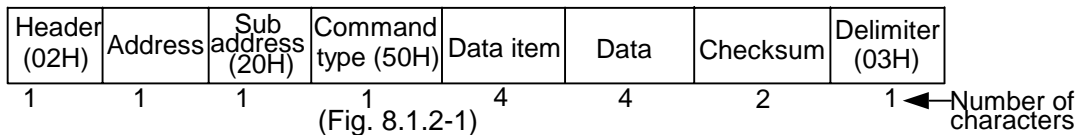

##### (2) Reading command

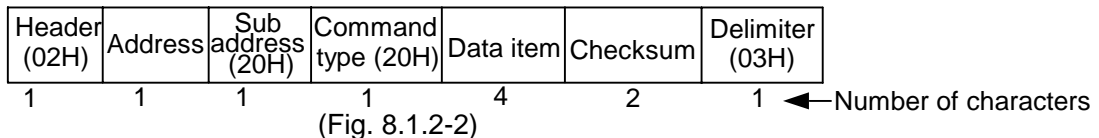

##### (3) Response with data

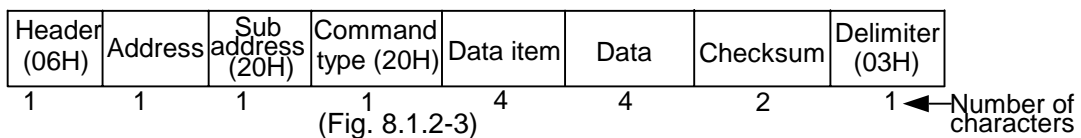

##### (4) Acknowledgement

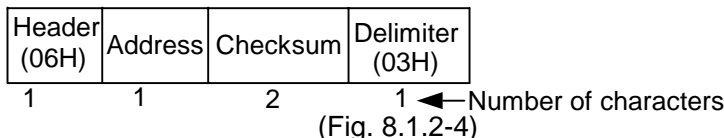

## (5) Negative acknowledgement

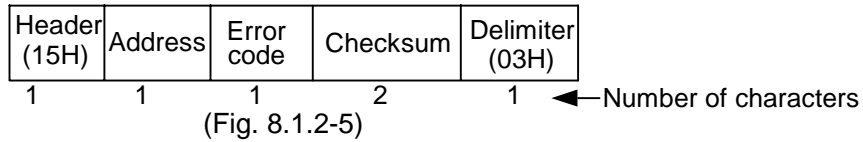

- Header** : Control code to represent the beginning of the command or the response  
ASCII codes are used.  
Setting command, Reading command : STX (02H) fixed  
Response with data, Acknowledgement: ACK (06H) fixed  
Negative acknowledgement : NAK (15H) fixed
- Address** : Numbers by which the master discerns each slave.  
Instrument number 0 to 94 (00H to 5EH) and Global address 95 (5FH)  
The numbers (20H to 7FH) are used by giving 20H of bias.  
95 (7FH) is called Global address, which is used when the same command is sent to all the slaves connected. However, a response is not returned.
- Sub address** : (20H) fixed
- Command type**: Code to discern Setting command (50H) and Reading command (20H)
- Data item** : Data classification of the command object  
Composed of hexadecimal 4 digits (Refer to the Communication command table)
- Data** : The contents of data (setting value) differs depending on the setting command.  
Composed of hexadecimal 4 digits (Refer to the Communication command table)
- Checksum** : 2-character data to detect communication errors
- Delimiter** : Control code to represent the end of command  
(03H) fixed
- Error code** : Represents an error type. Composed of hexadecimal 1 digit.  
1 (31H)-----Non-existent command  
2 (32H)-----Not used  
3 (33H)-----Setting value outside the setting range  
4 (34H)-----Unsettable status (e.g. AT is performing)

### 8.1.3 Checksum calculation

Checksum is used to detect receiving errors in the command or data.

Set the program for the master side as well to calculate the checksum of the response data from the slaves so that the communication errors can be checked.

The ASCII code (hexadecimal) corresponding to the characters which range from the address to that before the checksum is converted to binary notation, and the total value is calculated.

The lower 2-digits of the total value are converted to 2's complements and then to hexadecimal figures, that is, ASCII codes for the checksum.

#### Checksum calculation example

SV: 600°C (0258H)

Address (instrument number): 0 (20H)

- 1's complement: Reverse each binary bit. 0 will become 1 and vice versa.
- 2's complement: Add 1 to 1's complement.

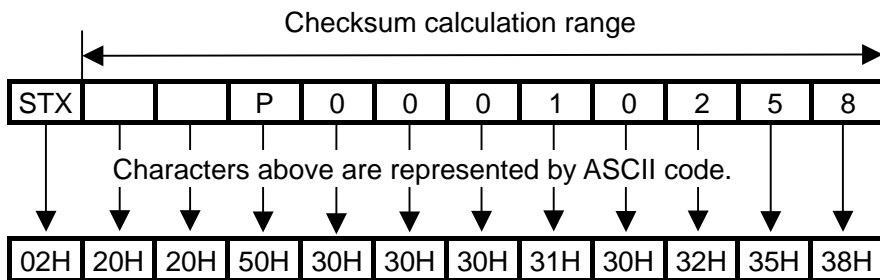

[Hexadecimal]	[Binary]		[1's complement]	
20H	0010 0000			
20H	0010 0000			
50H	0101 0000			
30H	0011 0000			
30H	0011 0000			
30H	0011 0000			
31H	0011 0001			
30H	0011 0000			
32H	0011 0010			
35H	0011 0101			
+38H	0011 1000			
	10 0010 0000		[2's complement]	$\begin{array}{r} 1101\ 1111 \\ + \quad \quad \quad 1 \\ \hline 1110\ 0000 \end{array}$
				[Hexadecimal]      E      0
				[ ASCII code ]      45H      30H
				Checksum

Setting command to which checksum and delimiter are added.

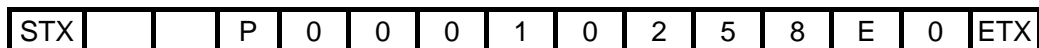
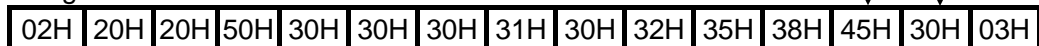

### 8.1.4 Contents of the command

#### Notes on the setting command and reading command

- Although the options are not applied, setting the optional items is possible by the setting command. However, they will not function.
- The memory can store up to 1,000,000 (one million) entries.  
If the number of setting times exceeds the limit, it cannot memorize the data.  
So frequent transmission via communication is not recommended.
- When connecting plural slaves, the address (instrument number) must not be duplicated.
- When sending a command by Global address [95 (7FH)], the same command is sent to all the slaves connected. However, the response is not returned.
- The instrument number and communication speed of the slave cannot be set by communication function.

#### Setting command

- For the settable range, refer to the Communication command table of this manual.
- All commands are composed of ASCII.
- The data (setting value, decimal) is converted to hexadecimal figures, and ASCII is used.  
Negative numbers are represented by 2's complement. When the data (setting value) has a decimal point, the whole number without a decimal point is used.

#### Reading command

- All commands are composed of ASCII.
- The data (setting value, decimal) is converted to hexadecimal figures, and ASCII is used.  
Negative numbers are represented by 2's complement. When the data (setting value) has a decimal point, the response is returned as a whole number without a decimal point.

### 8.1.5 Command example

#### (1) PV reading (Address 1)

- Reading command from the master

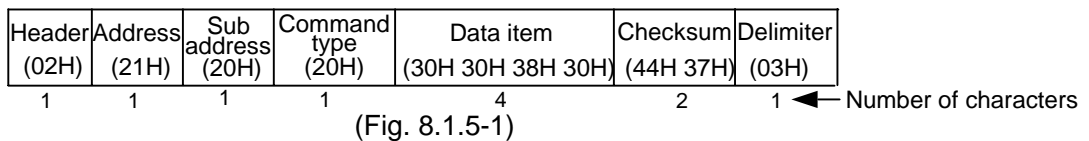

- Response from the slave in normal status [When PV=25°C (0019H)]

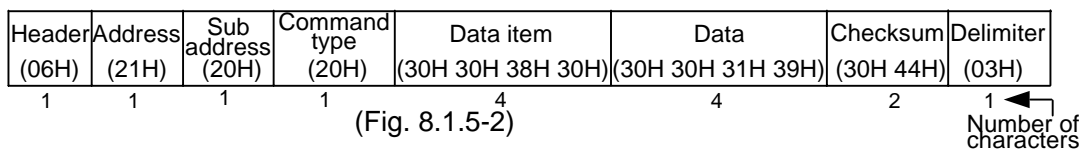

#### (2) SV reading (Address 1)

- Reading command from the master

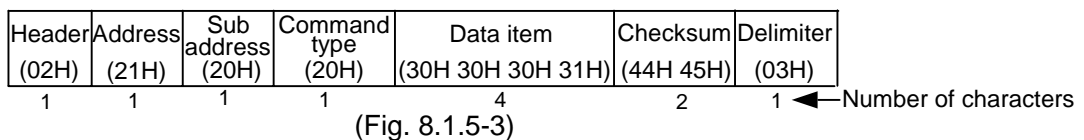

- Response from the slave in normal status [When SV=600°C (0258H)]

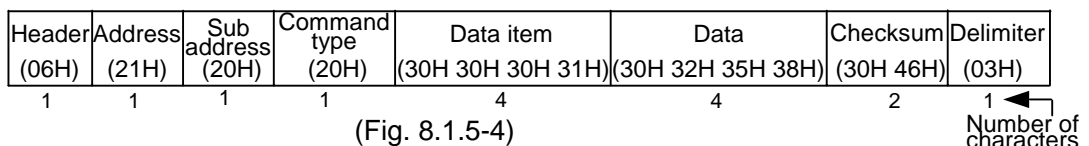

### (3) When SV is set to 600°C (0258H) (Address 1)

- Setting command from the master

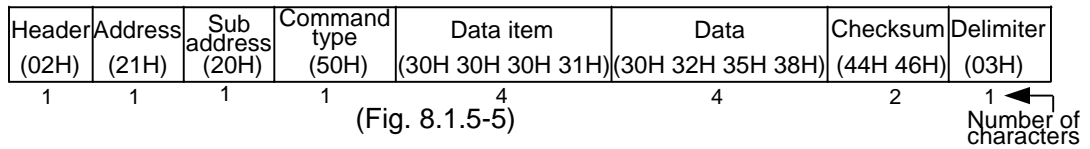

- Response from the slave in normal status

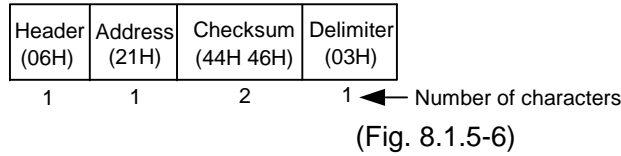

## 8.2 Modbus protocol

### 8.2.1 Transmission mode

There are 2 transmission modes (ASCII and RTU) in Modbus protocol.

### 8.2.2 ASCII mode

Hexadecimal (0 to 9, A to F), which is divided into high order (4-bit) and low order (4-bit) out of 8-bit binary data in the command is transmitted as ASCII characters.

Data format      Start bit        : 1 bit  
                          Data bit         : 7 bits  
                          Parity            : Even  
                          Stop bit         : 1 bit  
                          Error detection: LRC (Longitudinal Redundancy Check)  
                          Data interval : 1 second or less

### (1) Message configuration

ASCII mode message is configured to start by [: (colon)(3AH)] and end by [CR (carriage return) (0DH) + LF (Line feed)(0AH)]. See (Fig. 8.2.2-1).

Header (:)	Slave address	Function code	Data	Error check LRC	Delimiter (CR)	Delimiter (LF)
---------------	------------------	------------------	------	--------------------	-------------------	-------------------

(Fig. 8.2.2-1)

### Slave address

Slave address is an individual instrument number on the slave side and is set within the range 00H to 5FH (0 to 95).

The master identifies slaves by the slave address of the requested message.

The slave informs the master which slave is responding to the master by placing its own address in the response message.

Slave address 00H (broadcast address) can identify all the slaves. However slaves do not respond.

### Function code

The function code is the command code that makes the slave to undertake the following action types (Table 8.2.2-1).

(Table 8.2.2-1)

Function code	Contents
03 (03H)	Reading the setting value and information from slaves
06 (06H)	Setting to slaves

A function code is used to discern whether the response is normal(acknowledgement) or if any error (negative acknowledgement) has occurred when the slave returns the response message to the master.

When acknowledgement is returned, the slave simply returns the original function code.

When negative acknowledgement is returned, the MSB of the original function code is set as 1 for the response.

(For example, when the master sends a request message setting 10H to function code by mistake, slave returns 90H by setting the MSB to 1, because the former is an illegal function.)

For negative acknowledgement, exception code (Table 8.2.2-2) below is set to the data of response message and returned to the master in order to inform it that what kind of error has occurred.

(Table 8.2.2-2)

Exception code	Contents
1 (01H)	Illegal function (Non-existent function)
2 (02H)	Illegal data address (Non-existent data address)
3 (03H)	Illegal data value (Value outside the setting range)
17 (11H)	Shinko error code 4 (Unsettable status: During AT, etc.)

### Data

Data differs depending on the function code.

A request message from the master is composed of data item, number of data and setting data.

A response message from the slave is composed of number of bytes, data and exception code in negative acknowledgement.

Only one piece of data can be dealt with per message.

Therefore the number of data for ASCII mode is fixed as (30H 30H 30H 31H).

Effective range of data is -32768 to 32767 (8000H to 7FFFH).

### (2) ASCII mode error check

After calculating LRC (Longitudinal Redundancy Check) from the slave address to the end of data, the calculated 8-bit data is converted to two ASCII characters and are appended to the end of the message.

#### How LRC is calculated

- ① Create a message in RTU mode.
- ② Add all the values from the slave address to the end of data.  
This is assumed as X.
- ③ Make a complement for X (bit reverse). This is assumed as X.
- ④ Add a value of 1 to X. This is assumed as X.
- ⑤ Set X as an LRC to the end of the message.
- ⑥ Convert the whole message to ASCII characters.

### (3) ASCII mode message example

#### ① PV reading (Address 1)

- A request message from the master

The number of data indicates the data item to be read, and it is fixed as 1 (30H 30H 30H 31H).

Header	Slave address	Function code	Data item	Number of data	Error check LRC	Delimiter
(3AH)	(30H 31H)	(30H 33H)	(30H 30H 38H 30H)	(30H 30H 30H 31H)	(37H 42H)	(0DH 0AH)
1	2	2	4	4	2	2 ←

Number of characters

(Fig. 8.2.2-2)

- A response message from the slave in normal status [When PV=600°C (0258H)]  
The number of response bytes indicates the number of bytes of the data which has been read, and it is fixed as (30H 32H).

Header (3AH)	Slave address (30H 31H)	Function code (30H 33H)	Number of response bytes (30H 32H)	Data (30H 32H 35H 38H)	Error check LRC (41H 30H)	Delimiter (0DH 0AH)
1	2	2	2	4	2	2

← Number of characters

(Fig.8.2.2-3)

② **SV reading (Address 1)**

- Request message from the master  
The number of the data indicates the data item to be read, and it is fixed as 1 (30H 30H 30H 31H).

Header (3AH)	Slave address (30H 31H)	Function code (30H 33H)	Data item (30H 30H 30H 31H)	Number of data (30H 30H 30H 31H)	Error check LRC (46H 41H)	Delimiter (0DH 0AH)
1	2	2	4	4	2	2

← Number of characters

(Fig. 8.2.2-4)

- A response message from the slave in normal status [When SV=600°C (0258H)]  
The number of response bytes indicates the number of bytes of the data which has been read, and it is fixed as (30H 32H).

Header (3AH)	Slave address (30H 31H)	Function code (30H 33H)	Number of response bytes (30H 32H)	Data (30H 32H 35H 38H)	Error check LRC (41H 30H)	Delimiter (0DH 0AH)
1	2	2	2	4	2	2

← Number of characters

(Fig. 8.2.2-5)

- A response message from the slave in exception (error) status (When non-existent data address is sent)  
The function code MSB is set to 1 for the response message in exception (error) status (Value: 83H, ASCII: 38H 33H).  
If an exception code (Value: 02H, ASCII: 30H 32H Non-existent data address) is returned, the error can be determined by reading this code.

Header (3AH)	Slave address (30H 31H)	Function code (38H 33H)	Exception code (30H 32H)	Error check LRC (37H 41H)	Delimiter (0DH 0AH)
1	2	2	2	2	2

← Number of characters

(Fig. 8.2.2-6)

③ **When setting SV to 600°C (0258H) (Address 1)**

- A request message from the master

Header (3AH)	Slave address (30H 31H)	Function code (30H 36H)	Data item (30H 30H 30H 31H)	Data (30H 32H 35H 38H)	Error check LRC (39H 45H)	Delimiter (0DH 0AH)
1	2	2	4	4	2	2

← Number of characters

(Fig. 8.2.2-7)

- A response message from the slave in normal status

Header (3AH)	Slave address (30H 31H)	Function code (30H 36H)	Data item (30H 30H 30H 31H)	Data (30H 32H 35H 38H)	Error check LRC (39H 45H)	Delimiter (0DH 0AH)
1	2	2	4	4	2	2

← Number of characters

(Fig. 8.2.2-8)

- A response message from the slave in exception (error) status (When a value out of the setting range is set.)  
The function code MSB is set to 1 for the response message in exception (error) status (Value: 86H, ASCII: 38H 36H).  
If an exception code (Value: 03H, ASCII: 30H 33H Value out of the setting range) is returned, the error can be determined by reading this code.

Header (3AH)	Slave address (30H 31H)	Function code (38H 36H)	Exception code (30H 33H)	Error check LRC (37H 36H)	Delimiter (0DH 0AH)
1	2	2	2	2	2

(Fig. 8.2.2-9) ←Number of characters

### 8.2.3 RTU mode

8-bit binary data in command is transmitted as it is.

Data format Start bit : 1 bit  
Data bit : 8 bits  
Parity : No parity  
Stop bit : 1 bit  
Error detection : CRC-16 (Cyclic Redundancy Check)  
Data interval : 3.5 characters transmission time or less

#### (1) Message configuration

RTU mode is configured to start after idle time is processed for more than 3.5 characters transmission and end after idle time is processed for more than 3.5 characters transmission. (See Fig. 8.2.3-1)

3.5 idle characters	Slave address	Function code	Data	Error check CRC	3.5 idle characters
------------------------	------------------	------------------	------	--------------------	------------------------

(Fig. 8.2.3-1)

#### Slave address

Slave address is an individual instrument number on the slave side and is set within the range 00H to 5FH (0 to 95).

The master identifies slaves by the slave address of the requested message.

The slave informs the master which slave is responding to the master by placing its own address in the response message.

[Slave address 00H (broadcast address) can identify all the slaves. However slaves do not respond.]

#### Function code

The function code is the command code that makes the slave to undertake the following action types (Table 8.2.3-1).

(Table 8.2.3-1)

Function code	Contents
03 (03H)	Reading the setting value and information from slaves
06 (06H)	Setting to slaves

A function code is used to discern whether the response is normal (acknowledgement) or if any error (negative acknowledgement) has occurred when the slave returns the response message to the master.

When acknowledgement is returned, the slave simply returns the original function code.

When negative acknowledgement is returned, the MSB of the original function code is set as 1 for the response.

(For example, when the master sends request message setting 10H to function code by mistake, slave returns 90H by setting the MSB to 1, because the former is an illegal function.)

For negative acknowledgement, exception code (Table 8.2.3-2) below is set to the data of response message and returned to the master in order to inform it that what kind of error has occurred.

(Table 8.2.3-2)

Exception code	Contents
1 (01H)	Illegal function (Non-existent function)
2 (02H)	Illegal data address (Non-existent data address)
3 (03H)	Illegal data value (Value out of the setting range)
17 (11H)	Shinko error code 4 (Unsettable status: During AT, etc.)

### Data

Data differs depending on the function code.

A request message from the master side is composed of data item, number of data and setting data.

A response message from the slave side is composed of number of bytes, data and exception code in negative acknowledgement.

Only one piece of data can be dealt with per message. Therefore the number of data for RTU mode is fixed as 1 (0001H).

Effective range of data is -32768 to 32767 (8000H to 7FFFH).

### (2) RTU mode error check

After calculating CRC-16 (Cyclic Redundancy Check) from the slave address to the end of data, the calculated 16-bit data is appended to the end of message in sequence from low order to high order.

#### How CRC is calculated

In the CRC system, the information is divided by a polynomial series. The remainder is added to the end of the information and then transmitted. The generation of the polynomial series is as follows.

(Generation of the polynomial series:  $X^{16} + X^{15} + X^2 + 1$ )

- ① Initialize the CRC-16 data (assumed as X) (FFFFH).
- ② Calculate exclusive OR (XOR) with the 1st data and X. This is assumed as X.
- ③ Shift X one bit to the right. This is assumed as X.
- ④ When a carry is generated as a result of the shift, XOR is calculated by X of ③ and the fixed value (A001H). This is assumed as X. If a carry is not generated, go to step ⑤.
- ⑤ Repeat steps ③ and ④ until shifting 8 times.
- ⑥ XOR is calculated with the next data and X. This is assumed as X.
- ⑦ Repeat steps ③ to ⑤.
- ⑧ Repeat steps ③ to ⑤ up to the last data.
- ⑨ Set X as CRC-16 to the end of message in sequence from low order to high order.

### (3) RTU mode message example

#### ① PV reading (Address 1)

- Request message from the master

The number of data indicates the data item to be read, and it is fixed as 1 (0001H).

3.5 idle characters	Slave address (01H)	Function code (03H)	Data item (0080H)	Number of data (0001H)	Error check CRC (85E2H)	3.5 idle characters
	1	1	2	2	2	

← Number of characters

(Fig. 8.2.3-2)

- Response message from the slave in normal status [When PV=600°C (0258H)]

The number of response bytes indicates number of bytes of the data which has been read, and it is fixed as (02H).

3.5 idle characters	Slave address (01H)	Function code (03H)	Number of response bytes (02H)	Data (0258H)	Error check CRC (B8DEH)	3.5 idle characters
	1	1	1	2	2	

← Number of characters

(Fig. 8.2.3-3)

② **SV reading (Address 1)**

- Request message from the master

The number of data indicates the data item to be read, and it is fixed as 1 (0001H).

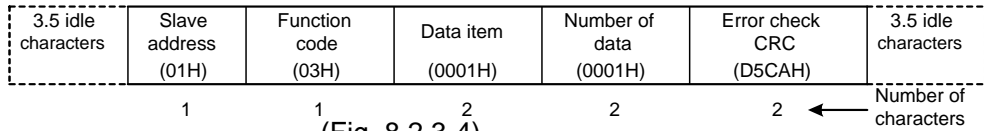

(Fig. 8.2.3-4)

- Response message from the slave in normal status [SV=600°C (0258H)]

The number of response bytes indicates number of bytes of the data which has been read, and it is fixed as (02H).

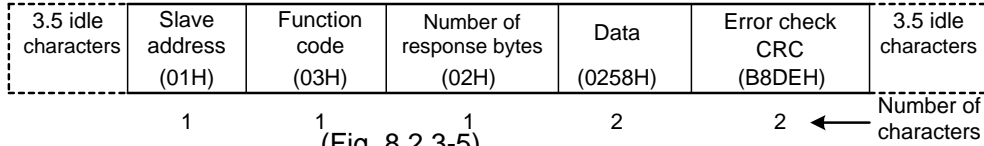

(Fig. 8.2.3-5)

- Response message from the slave in exception (error) status (When non-existent data address is sent)

The function code MSB is set to 1 for the response message in exception (error) status (83H).

If an exception code (02H: Non-existent data address) is returned, the error can be determined by reading this code.

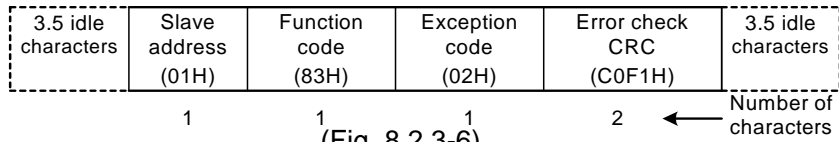

(Fig. 8.2.3-6)

③ **When SV is set to 600°C (0258H) (Address 1)**

- Request message from the master

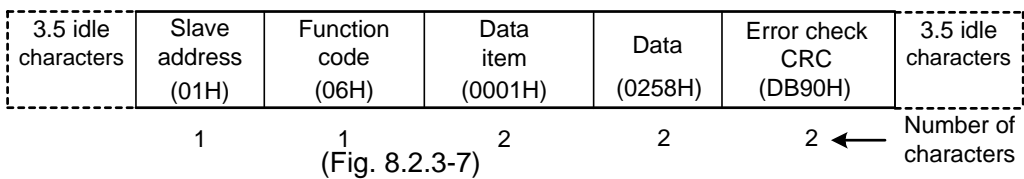

(Fig. 8.2.3-7)

- Response message from the slave in normal status

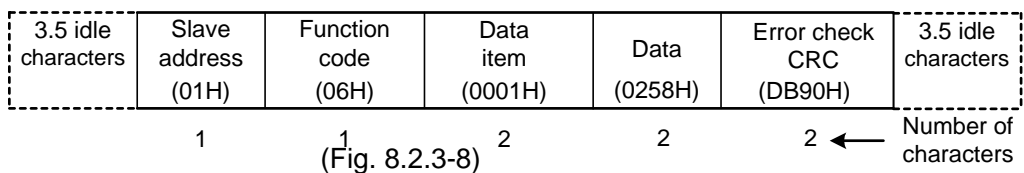

(Fig. 8.2.3-8)

- Response message from the slave in exception (error) status (When a value out of the setting range is set)

The function code MSB is set to 1 for the response message in exception (error) status (86H).

If an exception code (03H: Value out of the setting range) is returned, the error can be determined by reading this code.

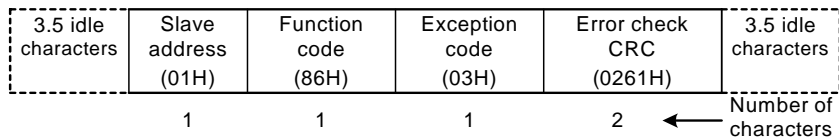

(Fig. 8.2.3-9)

## 9. Communication command table

### Setting/Reading command

Shinko command type	Modbus function code	Data item	Data
20H/50H	03H/06H	0001H: SV	Set value, Decimal point ignored
		0002H: Not used	
20H/50H	03H/06H	0003H: AT setting	0000H: Cancel 0001H: Perform
20H/50H	03H/06H	0004H: OUT1 proportional band	Set value, Decimal point ignored
20H/50H	03H/06H	0005H: OUT2 proportional band	Set value, Decimal point ignored
20H/50H	03H/06H	0006H: Integral time setting	Set value
20H/50H	03H/06H	0007H: Derivative time setting	Set value
20H/50H	03H/06H	0008H: OUT1 proportional cycle	Set value
20H/50H	03H/06H	0009H: OUT2 proportional cycle	Set value
20H/50H	03H/06H	000AH: Manual reset setting	Set value, Decimal point ignored
20H/50H	03H/06H	000BH: A1 (Alarm 1) setting	Set value, Decimal point ignored
20H/50H	03H/06H	000CH: A2 (Alarm 2) setting	Set value, Decimal point ignored
20H/50H	03H/06H	000DH: A3 (Alarm 3) setting	Set value, Decimal point ignored
20H/50H	03H/06H	000EH: A4 (Alarm 4) setting	Set value, Decimal point ignored
20H/50H	03H/06H	000FH: Heater burnout alarm 1 setting	Set value
20H/50H	03H/06H	0010H: Loop break alarm time setting	Set value, Decimal point ignored
20H/50H	03H/06H	0011H: Loop break alarm span setting	Set value, Decimal point ignored
20H/50H	03H/06H	0012H: Non-volatile memory data saving selection	0000H: Save 0001H: Save 0002H: Save 0003H: Unable to save
		0013H: Not used	
		0014H: Not used	
20H/50H	03H/06H	0015H: Sensor correction value setting	Set value, Decimal point ignored
20H/50H	03H/06H	0016H: Overlap/Dead band	Set value, Decimal point ignored
		0017H: Not used	
20H/50H	03H/06H	0018H: Scaling high limit setting	Set value, Decimal point ignored
20H/50H	03H/06H	0019H: Scaling low limit setting	Set value, Decimal point ignored
		001AH: Not used	
20H/50H	03H/06H	001BH: PV filter time constant setting	Set value, Decimal point ignored
20H/50H	03H/06H	001CH: OUT1 high limit setting	Set value
20H/50H	03H/06H	001DH: OUT1 low limit setting	Set value
20H/50H	03H/06H	001EH: OUT1 ON/OFF action hysteresis setting	Set value, Decimal point ignored
20H/50H	03H/06H	001FH: OUT2 action mode selection	0000H: Air cooling 0001H: Oil cooling 0002H: Water cooling
20H/50H	03H/06H	0020H: OUT2 high limit setting	Set value
20H/50H	03H/06H	0021H: OUT2 low limit setting	Set value
20H/50H	03H/06H	0022H: OUT2 ON/OFF action hysteresis setting	Set value, Decimal point ignored

20H/50H	03H/06H	0023H: A1 action selection (*1)	0000H: No alarm action 0001H: High limit alarm 0002H: Low limit alarm 0003H: High/Low limits alarm 0004H: High/Low limit range alarm 0005H: Process high alarm 0006H: Process low alarm 0007H: High limit alarm with standby 0008H: Low limit alarm with standby 0009H: High/Low limits alarm with standby
20H/50H	03H/06H	0024H: A2 action selection (*1)	The same as A1 action selection
20H/50H	03H/06H	0025H: A1 hysteresis setting	Set value, Decimal point ignored
20H/50H	03H/06H	0026H: A2 hysteresis setting	Set value, Decimal point ignored
20H/50H	03H/06H	0027H: A3 hysteresis setting	Set value, Decimal point ignored
20H/50H	03H/06H	0028H: A4 hysteresis setting	Set value, Decimal point ignored
20H/50H	03H/06H	0029H: A1 action delayed timer setting	Set value
20H/50H	03H/06H	002AH: A2 action delayed timer setting	Set value
20H/50H	03H/06H	002BH: A3 action delayed timer setting	Set value
20H/50H	03H/06H	002CH: A4 action delayed timer setting	Set value
20H/50H	03H/06H	0037H: Control Allowed/ Prohibited selection	0000H: Control Prohibited 0001H: Control Allowed
20H/50H	03H/06H	0038H: Control Allowed/ Prohibited selection when power-on	0000H: Control Prohibited when power-on 0001H: Control Allowed when power-on
20H/50H	03H/06H	0040H: Alarm 1 action Energized /Deenergized selection	0000H: Energized 0001H: Deenergized
		0041H: Not used	
20H/50H	03H/06H	0042H: A1 Hold function	0000H: Alarm Not holding 0001H: Alarm Holding
20H/50H	03H/06H	0043H: A2 Hold function	0000H: Alarm Not holding 0001H: Alarm Holding
20H/50H	03H/06H	0044H: Input type selection	0000H: K [-200 to 1370°C] 0001H: K [-199.9 to 500.0°C] 0002H: J [-200 to 1000°C] 0003H: R [0 to 1760°C] 0004H: S [0 to 1760°C] 0005H: B [0 to 1820°C] 0006H: E [-200 to 800°C] 0007H: T [-199.9 to 400.0°C] 0008H: N [-200 to 1300°C] 0009H: PL-II [0 to 1390°C] 000AH: C (W/Re5-26) [0 to 2315°C] 000BH: Pt100[-199.9 to 850.0°C]

20H/50H	03H/06H	0044H: Input type selection	000CH: JPt100 [-199.9to 500.0°C] 000DH: Pt100 [-200 to 850°C] 000EH: JPt100 [-200 to 500°C] 000FH: K [-320 to 2500°F] 0010H: K [-199.9 to 932.0°F] 0011H: J [-320 to 1800°F] 0012H: R [0 to 3200°F] 0013H: S [0 to 3200°F] 0014H: B [0 to 3300°F] 0015H: E [-320 to 1500°F] 0016H: T [-199.9 to 750.0°F] 0017H: N [-320 to 2300°F] 0018H: PL-II [0 to 2500°F] 0019H: C (W/Re5-26) [0 to 4200°F] 001AH: Pt100 [-199.9 to 999.9°F] 001BH: JPt100 [-199.9 to 900.0°F] 001CH: Pt100 [-300 to 1500°F] 001DH: JPt100 [-300 to 900°F] 001EH: 4 to 20mA DC [-1999 to 9999] 001FH: 0 to 20mA DC [-1999 to 9999] 0020H: 0 to 1V DC [-1999 to 9999] 0021H: 0 to 5V DC [-1999 to 9999] 0022H: 1 to 5V DC [-1999 to 9999] 0023H: 0 to 10V DC [-1999 to 9999]
20H/50H	03H/06H	0045H: Direct/Reverse action selection	0000H: Reverse action (Heating) 0001H: Direct action (Cooling)
		0046H: Not used	
20H/50H	03H/06H	0047H: AT bias setting	Set value, Decimal point ignored
20H/50H	03H/06H	0048H: ARW (anti-reset windup)	Set value
20H/50H	03H/06H	0049H: A3 action selection (*1)	The same as Alarm 1 action selection (p.33)
20H/50H	03H/06H	004AH: A4 action selection (*1)	The same as Alarm 1 action selection (p.33)
20H/50H	03H/06H	004BH: A3 Hold function	0000H: Alarm Not holding 0001H: Alarm Holding
20H/50H	03H/06H	004CH: A4 Hold function	0000H: Alarm Not holding 0001H: Alarm Holding
20H/50H	03H/06H	004DH: Heater burnout alarm 2	Set value, Decimal point ignored
20H/50H	03H/06H	0050H: Output status selection when input abnormal (*2)	0000H: Output OFF 0001H: Output ON
50H	06H	0051H: Alarm hold reset	0000H: Alarm status flag and standby reset (*3) 0001H: Alarm status flag reset

## Reading command

Shinko command type	Modbus function code	Data item	Data
20H	03H	0080H: PV reading	Current PV, Decimal point ignored
20H	03H	0081H: OUT1 MV reading	OUT1 MV, Decimal point ignored
20H	03H	0082H: OUT2 MV reading	OUT2 MV, Decimal point ignored
20H	03H	0085H: Status flag	<p>2<sup>0</sup> digit: Control output (OUT1) 0: OFF 1: ON (DC current output: Not decided)</p> <p>2<sup>1</sup> digit: Cooling output (OUT2) 0: OFF 1: ON</p> <p>2<sup>2</sup> digit: A1 output 0: OFF 1: ON</p> <p>2<sup>3</sup> digit: A2 output 0: OFF 1: ON</p> <p>2<sup>4</sup> digit: A3 output 0: OFF 1: ON</p> <p>2<sup>5</sup> digit: A4 output 0: OFF 1: ON</p> <p>2<sup>6</sup> digit: Heater burnout alarm output 1 0: OFF 1: ON (When sensor is burnt out, 0: OFF)</p> <p>2<sup>7</sup> digit: Loop break alarm output 0: OFF 1: ON</p> <p>2<sup>8</sup> digit: Overscale 0: OFF 1: ON</p> <p>2<sup>9</sup> digit: Underscale 0: OFF 1: ON</p> <p>2<sup>10</sup> digit: Actuator short circuit alarm output 1 0: OFF 1: ON</p> <p>2<sup>11</sup> digit: During AT 0: OFF 1: AT</p> <p>2<sup>12</sup> digit: Heater burnout alarm output 2 0: OFF 1: ON (When sensor is burnt out, 0: OFF)</p> <p>2<sup>13</sup> digit: Actuator short circuit alarm output 2 0: OFF 1: ON</p> <p>2<sup>14</sup> digit: Not used (Always 0)</p> <p>2<sup>15</sup> digit: Memory defect (EEPROM ERROR) 0: Normal 1: Defect</p>
20H	03H	0088H: CT1 input value	CT1 input value, Decimal point ignored
20H	03H	0089H: CT2 input value	CT2 input value, Decimal point ignored

20H	03H	00A1H: Instrument information reading	$2^0$ digit: Alarm 1 0: Not applied 1: Applied $2^1$ digit: Alarm 2 0: Not applied 1: Applied $2^2$ digit: Alarm 3 0: Not applied 1: Applied $2^3$ digit: Alarm 4 0: Not applied 1: Applied $2^4$ digit: Loop break alarm 0: Not applied 1: Applied $2^5$ digit: Heater burnout alarm 1 0: Not applied 1: Applied $2^6$ digit: Heater burnout alarm 2 0: Not applied 1: Applied $2^7$ digit: Heater burnout alarm rating 0: 100A 1: 20A $2^8$ digit: Heating/Cooling function 0: Not applied 1: Applied $2^9$ to $2^{15}$ digit: Not used (Always 0)
-----	-----	---------------------------------------	---

### Setting data

- When the data (setting value) has a decimal point, the decimal point is removed. The data is represented as a whole number, and expressed in hexadecimal figures.

### Data item

- (\*1) When the alarm action type is changed during Alarm 1, 2, 3, 4 action selection, the alarm setting value returns to the default value.  
The alarm output (A1) and status flag (A1, A2, A3, A4) are also initialized.
- (\*2) Selects whether to turn the control output (OUT1) and cooling output (OUT2) ON or OFF when the PV goes outside the control range.
- (\*3) In the case High limit alarm with standby, Low limit alarm with standby or High/Low limit alarm with standby is selected during Alarm action selection, and when alarm output is on, the alarm status returns to the standby again by selecting (0001H: Alarm status flag and standby reset), and the alarm status flag is also initialized.

### Note

Setting of OUT1 (OUT2) high limit or low limit value during standby or warm-up status is not effective.

# 10. Running

## 10.1 Setup



### Notice

Before setup, check communication parameter setting, mounting and wiring, referring to chapters “4 Communication parameter setting”, “5 Mounting” and “6 Wiring”.

#### (1) Switch power to the unit ON.

The power indicator (POW) lights up and the unit will be in command waiting status.

#### (2) Set up the unit.

The input type, alarm action and control action, etc. have to be set according to the users' using conditions before using this unit.

Perform setup from the host computer through communication function.

Shaded portions  are setup items.

If the NCL-13A is incorporated into other industrial equipment after setting has been completed, or if the user's specification is the same as the default value of the NCL-13A, then it is not necessary to set up.

Proceed to Section “10.2 Start running”.

(Table 10.1-1)

Setting item	Setting range	Default value
SV	Scaling low limit value to Scaling high limit value	0°C
AT setting	0000H: Cancel 0001H: Perform	0000H: Cancel
OUT1 proportional band setting	0.0 to 110.0%	2.5%
OUT2 proportional band setting	0.0 to 10.0 times OUT1 proportional band	1.0 times
Integral time setting	0 to 1000s	200s
Derivative time setting	0 to 300s	50s
ARW setting	0 to 100%	50%
OUT1 proportional cycle setting	1 to 120s	R/M: 30s S/M: 3s C/M: 3s
OUT2 proportional cycle setting	1 to 120s	3s
Manual reset setting	±Proportional band converted value	0.0°C
Alarm 1 setting	Refer to (Table 10.1-2).	0°C
Alarm 2 setting	Refer to (Table 10.1-2).	0°C
Alarm 3 setting	Refer to (Table 10.1-2).	0°C
Alarm 4 setting	Refer to (Table 10.1-2).	0°C
Heater burnout alarm 1 setting	0.0 to 100.0A (Setting to 0.0 disables the function.)	0.0A
Heater burnout alarm 2 setting	0.0 to 100.0A (Setting to 0.0 disables the function.)	0.0A
Loop break alarm time setting	0 to 200 min.	0 minutes

Loop break alarm span setting	0 to 150°C(F) or 0.0 to 150.0°C(F) For DC input: 0 to 1500	0°C
Non-volatile memory data saving selection	0000H: ) Data save 0001H: ) 0002H: ) 0003H: Unable to save	0000H: Data save
Sensor correction setting	-100.0 to 100.0°C(F) For DC input: -1000 to 1000	0.0°C
Scaling high limit setting	Scaling low limit value to Input range high limit value	1370°C
Scaling low limit setting	Input range low limit value to Scaling high limit value	-200°C
Alarm 1 action selection	0000H: No alarm action 0001H: High limit alarm 0002H: Low limit alarm 0003H: High/Low limits alarm 0004H: High/Low limit range alarm 0005H: Process high alarm 0006H: Process low alarm 0007H: High limit alarm with standby 0008H: Low limit alarm with standby 0009H: High/Low limits alarm with standby	0000H: No alarm action
Alarm 2 action selection	The same as Alarm 1 action selection	0000H: No alarm
Alarm 3 action selection	The same as Alarm 1 action selection	0000H: No alarm
Alarm 4 action selection	The same as Alarm 1 action selection	0000H: No alarm
Alarm 1 hysteresis setting	0.1 to 100.0°C(F) For DC input: 1 to 1000	1.0°C
Alarm 2 hysteresis setting	0.1 to 100.0°C(F) For DC input: 1 to 1000	1.0°C
Alarm 3 hysteresis setting	0.1 to 100.0°C(F) For DC input: 1 to 1000	1.0°C
Alarm 4 hysteresis setting	0.1 to 100.0°C(F) For DC input: 1 to 1000	1.0°C
Alarm 1 action delayed timer setting	0 to 9999s	0s
Alarm 2 action delayed setting	0 to 9999s	0s
Alarm 3 action delayed setting	0 to 9999s	0s
Alarm 4 action delayed setting	0 to 9999s	0s
Control Allowed/Prohibited	0000H: Control Prohibited 0001H: Control Allowed	0000H: Control prohibited
Control Allowed/Prohibited when power-on	0000H: Control Prohibited when power-on 0001H: Control Allowed when power-on	0000H: Control Prohibited when power-on
Alarm 1 action Energized/Deenergized selection	0000H: Energized 0001H: Deenergized	0000H: Energized

Alarm 1 Hold function selection	0000H: Alarm Not holding 0001H: Alarm Holding	0000H: Alarm Not holding
Alarm 2 Hold function selection	0000H: Alarm Not holding 0001H: Alarm Holding	0000H: Alarm Not holding
Alarm 3 Hold function selection	0000H: Alarm Not holding 0001H: Alarm Holding	0000H: Alarm Not holding
Alarm 4 Hold function selection	0000H: Alarm Not holding 0001H: Alarm Holding	0000H: Alarm Not holding
Input type selection (*1)	0000H: K [-200 to 1370°C] 0001H: K [-199.9 to 500.0°C] 0002H: J [-200 to 1000°C] 0003H: R [0 to 1760°C] 0004H: S [0 to 1760°C] 0005H: B [0 to 1820°C] 0006H: E [-200 to 800°C] 0007H: T [-199.9 to 400.0°C] 0008H: N [-200 to 1300°C] 0009H: PL-II [0 to 1390°C] 000AH: C(W/Re5-26) [0 to 2315°C] 000BH: Pt100 [-199.9 to 850.0°C] 000CH: JPt100 [-199.9 to 500.0°C] 000DH: Pt100 [-200 to 850°C] 000EH: JPt100 [-200 to 500°C] 000FH: K [-320 to 2500°F] 0010H: K [-199.9 to 932.0°F] 0011H: J [-320 to 1800°F] 0012H: R [0 to 3200°F] 0013H: S [0 to 3200°F] 0014H: B [0 to 3300°F] 0015H: E [-320 to 1500°F] 0016H: T [-199.9 to 750.0°F] 0017H: N [-320 to 2300°F] 0018H: PL-II [0 to 2500°F] 0019H: C (W/Re5-26) [0 to 4200°F] 001AH: Pt100 [-199.9 to 999.9°F] 001BH: JPt100 [-199.9 to 900.0°F] 001CH: Pt100 [-300 to 1500°F] 001DH: JPt100 [-300 to 900°F] 001EH: 4 to 20mA DC [-1999 to 9999] 001FH: 0 to 20mA DC [-1999 to 9999] 0020H: 0 to 1V DC [-1999 to 9999] 0021H: 0 to 5V DC [-1999 to 9999] 0022H: 1 to 5V DC [-1999 to 9999] 0023H: 0 to 10V DC [-1999 to 9999]	0000H: K [-200 to 1370°C]
PV filter time constant setting	0.0 to 10.0s	0.0s (*2)
OUT1 high limit setting	OUT1 low limit value to 100% (A/M: OUT1 low limit value to 105%)	100%
OUT1 low limit setting	0% to OUT1 high limit value (A/M: -5% to OUT1 high limit value)	0%

(\*1) For DC current input, connect 50Ω shunt resistor (sold separately).

(\*2) If setting value is too large, it affects control result due to the delay of the response.

OUT1 ON/OFF action hysteresis setting	0.1 to 100.0°C (F) For DC input: 1 to 1000	1.0°C
OUT2 action mode selection	0000H: Air cooling (linear characteristic) 0001H: Oil cooling (1.5th power of the linear characteristic) 0002H: Water cooling (2nd power of the linear characteristic)	0000H: Air cooling
OUT2 high limit setting	OUT2 low limit value to 100% (A/M: OUT2 low limit value to 105%)	100%
OUT2 low limit setting	0% to OUT2 high limit value (A/M: -5% to OUT2 high limit value)	0%
OUT2 ON/OFF action hysteresis setting	-100.0 to 100.0°C (F) For DC input: -1000 to 1000	1.0°C
Overlap/Dead band setting	0.1 to 100.0°C (F) For DC input: 1 to 1000	0.0°C
Direct/Reverse action selection	0000H: Reverse (Heating) action 0001H: Direct (Cooling) action	0000H: Reverse (Heating)
AT bias setting	0 to 50°C (0 to 100°F) or 0.0 to 50.0°C (0.0 to 100.0°F) For DC input: Not available	20°C
Output status selection when input abnormal	0000H: Output OFF 0001H: Output ON	0000H: Output OFF

(Table 10.1-2)

Alarm action	Setting range
High limit alarm	- (Scaling span) to Scaling span
Low limit alarm	- (Scaling span) to Scaling span
High/Low limits alarm	0 to Scaling span
High/Low limit range alarm	0 to Scaling span
Process high alarm	Scaling low limit to Scaling high limit value
Process low alarm	Scaling low limit to Scaling high limit value
High limit alarm with standby	- (Scaling span) to Scaling span
Low limit alarm with standby	- (Scaling span) to Scaling span
High/Low limits alarm with standby	0 to Scaling span

- The negative minimum setting value: -199.9 or -1999  
The positive maximum value: 999.9 or 9999
- Setting to 0 or 0.0 disables the function.

- ① **Command example: When input type “Pt100 [-199.9 to 850.0℃]: 000BH” is selected**  
 (Shinko protocol, Address 1)

	Caution
When changing the input from DC voltage to other inputs, remove the sensor connected to this unit first, then change for the input.	

- Setting command from the master

Header (02H)	Address (21H)	Sub address (20H)	Command type (50H)	Data item (30H 30H 34H 34H)	Data (30H 30H 30H 42H)	Checksum (44H 35H)	Delimiter (03H)
1	1	1	1	4	4	2	1 ←

Number of characters

(Fig. 10.1-1)

- Response from the slave in normal status

Header (06H)	Address (21H)	Checksum (44H 46H)	Delimiter (03H)
1	1	2	1 ←

Number of characters

(Fig. 10.1-2)

- ② **Command example: When Alarm 1 action “High limit: 0001H” is selected**  
 (Shinko protocol, Address 1)

- Setting command from the master

Header (02H)	Address (21H)	Sub address (20H)	Command type (50H)	Data item (30H 30H 32H 33H)	Data (30H 30H 30H 31H)	Checksum (45H 39H)	Delimiter (03H)
1	1	1	1	4	4	2	1 ←

Number of characters

(Fig. 10.1-3)

- Response from the slave in normal status

Header (06H)	Address (21H)	Checksum (44H 46H)	Delimiter (03H)
1	1	2	1 ←

Number of characters

(Fig. 10.1-4)

## 10.2 Start running.



### Notice

Before starting running, check communication parameter setting, mounting and wiring, referring to chapters “4 Communication parameter setting”, “5 Mounting” and “6 Wiring”.

#### (1) Turn the power to the unit ON.

The power indicator (POW) lights up and the unit will be in command waiting status.

#### (2) Set the value.

Set each value, referring to “9 Communication command table”.

- ① **Command example: When SV is set to 600°C (0258H)**  
(Shinko protocol, Address 1)

- Setting command from the master

Header (02H)	Address (21H)	Sub address (20H)	Command type (50H)	Data item (30H 30H 30H 31H)	Data (30H 32H 35H 38H)	Checksum (44H 46H)	Delimiter (03H)
1	1	1	1	4	4	2	1

Number of characters

(Fig. 10.2-1)

- Response from the slave in normal status

Header (06H)	Address (21H)	Checksum (44H 46H)	Delimiter (03H)
1	1	2	1

Number of characters

(Fig. 10.2-2)

- ② **Command example: When Alarm 1 value is set to 10°C (000AH)**  
(Shinko protocol, Address 1)

- Setting command from the master

Header (02H)	Address (21H)	Sub address (20H)	Command type (50H)	Data item (30H 30H 30H 42H)	Data (30H 30H 30H 41H)	Checksum (43H 43H)	Delimiter (03H)
1	1	1	1	4	4	2	1

Number of characters

(Fig. 10.2-3)

- Response from the slave in normal status

Header (06H)	Address (21H)	Checksum (44H 46H)	Delimiter (03H)
1	1	2	1

Number of characters

(Fig. 10.2-4)

#### (3) Turn the load circuit power ON.

During running or when the power to the unit is turned on, Control Allowed/Prohibited can be selected.

If Control Allowed is selected during Control Allowed/Prohibited selection when power-on (0038H), control starts so as to maintain the control target at the SV.

If Control Prohibited is selected, the unit switches to standby status and does not perform control action after the power is turned on.

During running, when Control Allowed is selected during Control Allowed/Prohibited selection (0037H), control starts so as to maintain the control target at the SV.

When Control Prohibited is selected, the unit switches to the standby and control stops.

**Note: When the power is turned on, Control Allowed/Prohibited selection (0038H) has priority.**

### 10.3 Output MV (manipulated variable) reading

#### In the case of OUT1 MV reading (Address 1)

- Reading command from the master

Header (02H)	Address (21H)	Sub address (20H)	Command type (20H)	Data item (30H 30H 38H 31H)	Checksum (44H 36H)	Delimiter (03H)
1	1	1	1	4	2	1 ← Number of characters

(Fig. 10.3-1)

- Response of the slave in normal status (OUT1 MV: 50.0% [01F4H])

Header (06H)	Address (21H)	Sub address (20H)	Command type (20H)	Data item (30H 30H 38H 31H)	Data (30H 31H 46H 34H)	Checksum (46H 42H)	Delimiter (03H)
1	1	1	1	4	4	2	1 ← Number of characters

(Fig. 10.3-2)

The NCL-13A returns 500 as a response, ignoring the decimal point in 50.0% from the OUT1 MV.

### 10.4 Control Allowed/Prohibited selection

#### Command example: When Control Allowed is selected (Shinko protocol, Address 1)

- Setting command from the master

Header (02H)	Address (21H)	Sub address (20H)	Command type (50H)	Data item (30H 30H 33H 37H)	Data (30H 30H 30H 31H)	Checksum (45H 34H)	Delimiter (03H)
1	1	1	1	4	4	2	1 ← Number of characters

(Fig. 10.4-1)

- Response from the slave in normal status

Header (06H)	Address (21H)	Checksum (44H 46H)	Delimiter (03H)
1	1	2	1 ← Number of characters

(Fig. 10.4-2)

#### Command example: When Control Prohibited is selected (Shinko protocol, Address 1)

- Setting command from the master

Header (02H)	Address (21H)	Sub address (20H)	Command type (50H)	Data item (30H 30H 33H 37H)	Data (30H 30H 30H 30H)	Checksum (45H 35H)	Delimiter (03H)
1	1	1	1	4	4	2	1 ← Number of characters

(Fig. 10.4-3)

- Response from the slave in normal status

Header (06H)	Address (21H)	Checksum (44H 46H)	Delimiter (03H)
1	1	2	1 ← Number of characters

(Fig. 10.4-4)

## 10.5 Auto-tuning Perform/Cancel.

### Notice

- Perform the auto-tuning during the trial run.
- Auto-tuning can be performed in PID action with the status of Control Allowed.
- During PID auto-tuning, none of the setting items can be set.  
If setting command is sent, Negative acknowledgement [NAK: Error code 4 (Unsettable status)] is returned.
- If auto-tuning is canceled during process, P, I, D and ARW values return to values set before the auto-tuning was performed.  
If auto-tuning has not finished 4 hours after it has started, it is automatically finished.
- If power failure occurs during PID auto-tuning, the auto-tuning stops.

#### Command example: When Auto-tuning Perform is selected (Shinko protocol, Address 1)

- Setting command from the master

Header (02H)	Address (21H)	Sub address (20H)	Command type (50H)	Data item (30H 30H 30H 33H)	Data (30H 30H 30H 31H)	Checksum (45H 42H)	Delimiter (03H)
1	1	1	1	4	4	2	1 ←

(Fig. 10.4-1) Number of characters

- Response from the slave in normal status

Header (06H)	Address (21H)	Checksum (44H 46H)	Delimiter (03H)
1	1	2	1 ←

(Fig. 10.4-2) Number of characters

#### Command example: When Auto-tuning Cancel is selected (Shinko protocol, Address 1)

- Setting command from the master

Header (02H)	Address (21H)	Sub address (20H)	Command type (50H)	Data item (30H 30H 30H 33H)	Data (30H 30H 30H 30H)	Checksum (45H 43H)	Delimiter (03H)
1	1	1	1	4	4	2	1 ←

(Fig. 10.4-3) Number of characters

- Response from the slave in normal status

Header (06H)	Address (21H)	Checksum (44H 46H)	Delimiter (03H)
1	1	2	1 ←

(Fig. 10.4-4) Number of characters

## Auto-tuning (AT)

In order to decide each value of P, I, D and ARW automatically, the auto-tuning process should be made to fluctuate to obtain an optimal value.

### (1) In the case of a large difference between the setting value and processing temperature as the temperature is rising.

When AT bias is set to 20°C, the AT process will fluctuate at the temperature 20°C lower than the setting value.

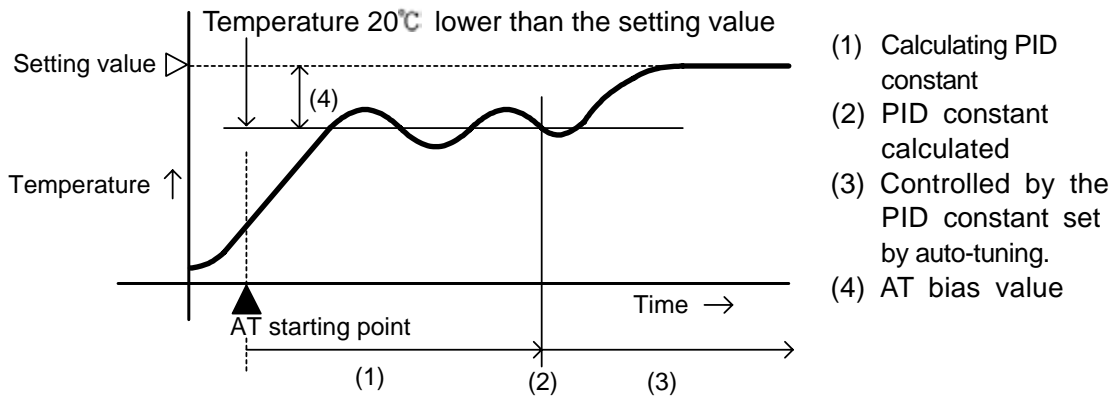

(Fig. 10.5-1)

### (2) In the case of a stable control

The AT process will fluctuate around the setting value.

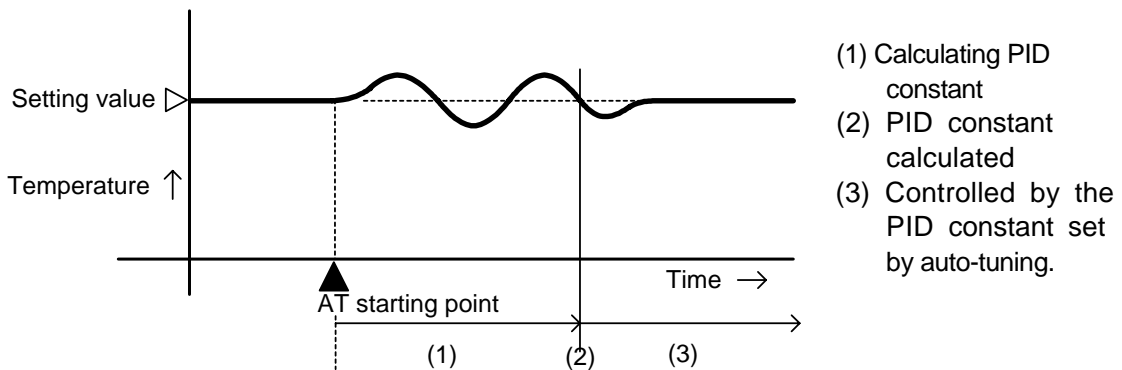

(Fig. 10.5-2)

### (3) In the case of a large difference between the setting value and processing temperature as the temperature is falling

When AT bias is set to 20°C, the AT process will fluctuate at the temperature 20°C higher than the setting value.

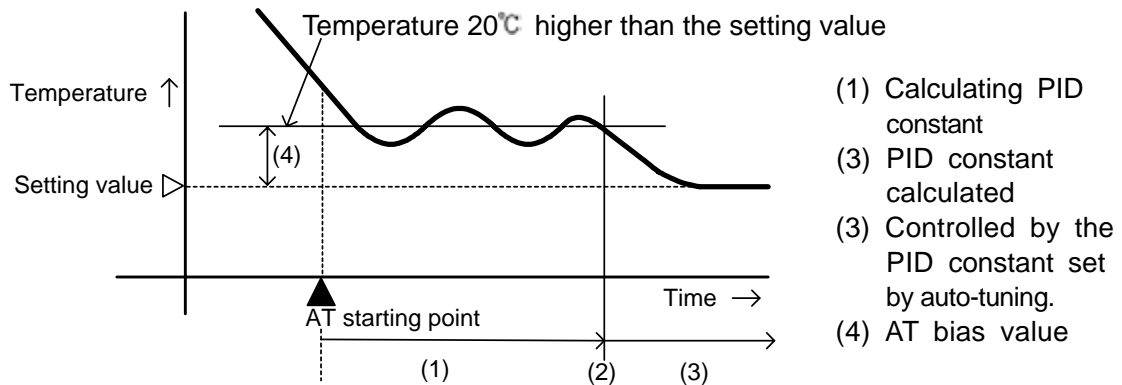

(Fig. 10.5-3)

For DC input, AT process will fluctuate around the setting value under conditions described in (1), (2) and (3).

# 11. Control action explanation

## 11.1 P, I, D and ARW

### (1) Proportional band (P)

Proportional action is the action which the control output varies in proportion to the deviation between the setting value and the processing temperature.

If the proportional band is narrowed, even if the output changes by a slight variation of the processing temperature, better control results can be obtained as the offset decreases.

However, if the proportional band is narrowed too much, even slight disturbances may cause variation in the processing temperature, control action changes to ON/OFF action and the so-called hunting phenomenon occurs.

Therefore, when the processing temperature comes to the balanced position near the setting value and a constant temperature is maintained, the most suitable value is selected by gradually narrowing the proportional band while observing the control results.

### (2) Integral time (I)

Integral action is used to eliminate offset. When the integral time is shortened, the returning speed to the setting point is accelerated. However, the cycle of oscillation is also accelerated and the control becomes unstable.

### (3) Derivative time (D)

Derivative action is used to restore the change in the processing temperature according to the rate of change. It reduces the amplitude of overshoot and undershoot width.

If the derivative time is shortened, restoring value becomes small, and if the derivative time is extended, an excessive returning phenomenon may occur and the control system may oscillate.

### (4) Anti-reset windup (ARW)

ARW (Anti-reset windup) prevents overshoot caused by the integral action. The smaller the ARW value, the less the overshoot caused by the integral action in the transition status, however it takes time until stabilization.

When setting ARW manually, set it to the closest MV (manipulated variable) when the control is stabilized.

If MV is not determined, perform trial run at default value (50%)

**P, I, D and ARW values are automatically set if auto-tuning is performed.**

## 11.2 Control output (OUT1) action

	Heating (Reverse) action			Cooling (Direct) action		
Control action						
Relay contact output R/M						
Non-contact voltage output S/M						
DC current output A/M						
Open collector output C/M						
Indicator (OUT) Green						

: Acts ON (lit) or OFF (unlit).

### 11.3 Control output (OUT1) ON/OFF action

	Heating (Reverse) action		Cooling (Direct) action	
Control action				
Relay contact output R/M				
Non-contact voltage output S/M				
DC current output A/M				
Open collector output C/M				
Indicator (OUT) Green				

: Acts ON (lit) or OFF (unlit).

### 11.4 Heating/Cooling control action (DC option)

Control action			
Relay contact output R/M			
Non-contact voltage output S/M			
DC current output A/M			
Open collector output C/M			
DC			
Indicator (OUT) Green			

: Acts ON (lit) or OFF (unlit).

: Represents heating control action.

: Represents cooling control action.

## When setting dead band

Control action				
	Relay contact output R/M			
Non-contact voltage output S/M				
DC current output A/M				
Open collector output C/M				
DC				
Indicator (OUT) Green				

- : Acts ON (lit) or OFF (unlit).
- : Represents heating control action.
- : Represents cooling control action.

## When setting overlap band

Control action	<p>The diagram shows a control action graph. The y-axis represents the control signal, with 'ON' at the top and 'OFF' at the bottom. A solid line represents the heating action, which starts at 'ON' and decreases linearly to 'OFF' at the 'SV setting' point. A dashed line represents the cooling action, which starts at 'OFF' and increases linearly to 'ON' at the 'SV setting' point. The 'Overlap band' is the region where both heating and cooling actions are active. Above the graph, 'OUT1 P-band' and 'OUT2 P-band' are indicated with arrows.</p>		
Relay contact output R/M	<p>Three diagrams show relay contact outputs between terminals 4 and 5. In the first, terminal 5 is connected to terminal 4. In the second, terminal 5 is connected to terminal 4 with a dashed line. In the third, terminal 5 is connected to terminal 4 with a solid line.</p> <p>Cycle action is performed according to deviation.</p>		
Non-contact voltage output S/M	<p>Three diagrams show non-contact voltage outputs between terminals 4 and 5. The first is labeled '12V DC', the second '12/0V DC', and the third '0V DC'. Each diagram shows terminal 5 connected to terminal 4.</p> <p>Cycle action is performed according to deviation.</p>		
DC current output A/M	<p>Three diagrams show DC current outputs between terminals 4 and 5. The first is labeled '20mA DC', the second '20 to 4mA DC', and the third '4mA DC'. Each diagram shows terminal 5 connected to terminal 4.</p> <p>Changes continuously according to deviation.</p>		
Open collector output C/M	<p>Three diagrams show open collector outputs between terminals 4 and 5. The first is labeled 'ON', the second 'ON/OFF', and the third 'OFF'. Each diagram shows terminal 5 connected to terminal 4.</p> <p>Cycle action is performed according to deviation.</p>		
DC	<p>Three diagrams show DC outputs between terminals 6 and 7. The first is labeled 'OFF', the second 'OFF/ON', and the third 'ON'. Each diagram shows terminal 7 connected to terminal 6.</p> <p>Cycle action is performed according to deviation.</p>		
Indicator (OUT) Green	<p>A horizontal bar representing the indicator state. The left portion is solid black and labeled 'Lit'. The middle portion is hatched and labeled 'Lit'. The right portion is white and labeled 'Unlit'.</p>		

: Acts ON (lit) or OFF (unlit).

: Represents heating control action.

: Represents cooling control action.

### 11.5 Alarm 1, Alarm 2, Alarm 3 and Alarm 4 actions

	High limit alarm	Low limit alarm
Alarm action		
Alarm 1 output		
	High/Low limits alarm	High/Low limit range alarm
Alarm action		
Alarm 1 output		
	Process high alarm	Process low alarm
Alarm action		
Alarm 1 output		
	High limit alarm with standby	Low limit alarm with standby
Alarm action		
Alarm 1 output		

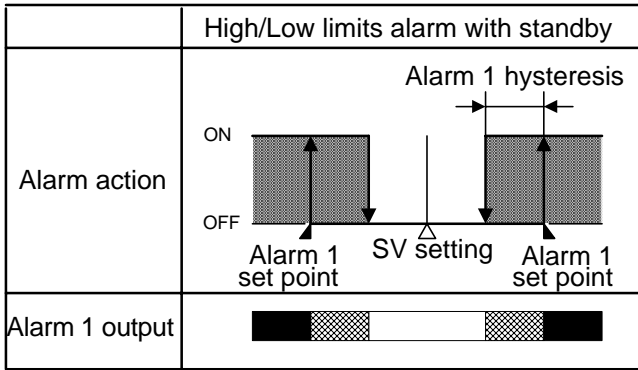

- : A1 output terminals 6 and 7 are connected (ON).
- : A1 output terminals 6 and 7 are connected (ON) or disconnected (OFF).
- : A1 output terminals 6 and 7 are disconnected (OFF).
- : Standby functions.

### 11.6 Heater burnout alarm/Actuator short circuit alarm action (W, W3 option)

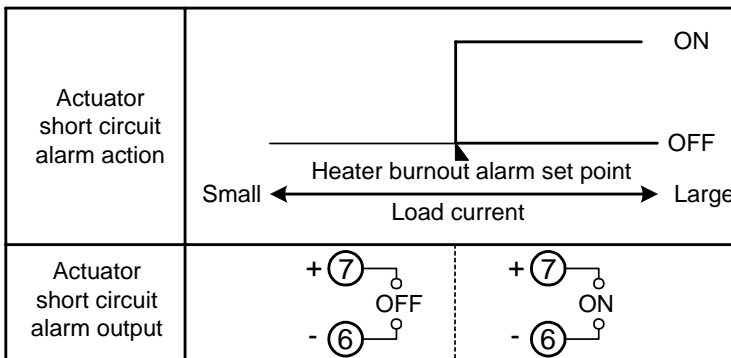
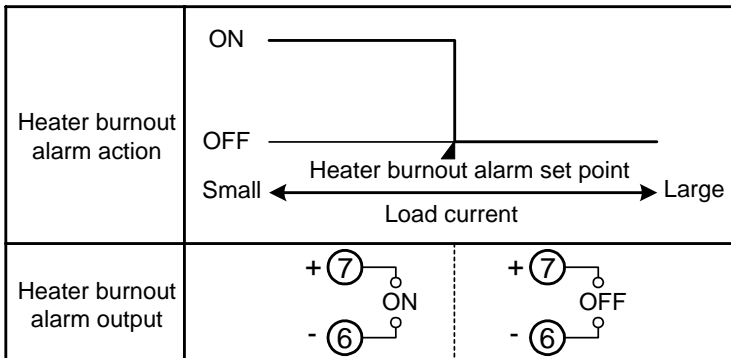

Heater burnout alarm and Actuator short circuit alarm use Event output terminals for their outputs.

Alarm 1 and Loop break alarm (LA option) use common output terminals.

If Heating/Cooling control output (DC option) is applied, Event output terminals are used as a cooling output. Therefore, Heater burnout alarm/Actuator short circuit alarm cannot be outputted.

# 12. Attached functions

## 12.1 Self-diagnosis

The CPU is monitored by a watchdog timer, and when any abnormal status is found on the CPU, the instrument is switched to warm-up status.

## 12.2 Automatic cold junction temperature compensation (Thermocouple input type)

This detects the temperature at the connecting terminal between thermocouple and the instrument, and always keeps it on the same status as when the reference junction is located at 0°C (32°F).

## 12.3 Burnout

When the thermocouple or RTD input is burnt out, control output (OUT1) and cooling output (OUT2) are turned off. For DC current output type, control output (OUT1) outputs OUT1 low limit value.

## 12.4 Output status selection when input abnormal

Selects control output (OUT1) and cooling output (OUT2) ON or OFF when the PV goes outside the control range.

## 12.5 Input abnormality

- Relay contact output (-R/M), Non-contact voltage output (-S/M) and Open collector output (-C/M) (Table 12.5-1)

		Output status			
Output status selection when input abnormal	Input value	OUT1		OUT2	
		Direct action	Reverse action	Direct action	Reverse action
ON	When exceeding Control range high limit	Outputs corresponding to MV	Outputs corresponding to MV	Outputs corresponding to MV	Outputs corresponding to MV
OFF		OFF	OFF	OFF	OFF
ON	When dropping below Control range low limit	Outputs corresponding to MV	Outputs corresponding to MV	Outputs corresponding to MV	Outputs corresponding to MV
OFF		OFF	OFF	OFF	OFF

When input is abnormal, control output (OUT1) and cooling output (OUT2) status have no relation to OUT1 (OUT2) high limit value and OUT1 (OUT2) low limit value.

- DC current output (-A/M) (Table 12.5-2)

		Output status			
Output status selection when input abnormal	Input value	OUT1		OUT2	
		Direct action	Reverse action	Direct action	Reverse action
ON	When exceeding Control range high limit	Outputs corresponding to MV	Outputs corresponding to MV	Outputs corresponding to MV	Outputs corresponding to MV
OFF		OFF or (OUT1 low limit value)	OFF or (OUT1 low limit value)	OFF	OFF
ON	When dropping below Control range low limit	Outputs corresponding to MV	Outputs corresponding to MV	Outputs corresponding to MV	Outputs corresponding to MV
OFF		OFF or (OUT1 low limit value)	OFF or (OUT1 low limit value)	OFF	OFF

When input is abnormal, control output (OUT1) status has relation to the OUT1 high limit value and OUT1 low limit value. However, the cooling output (OUT2) status has no relation to OUT2 high limit value and OUT2 low limit value.

## Thermocouple and RTD input

Control range

- Range without a decimal point except for the RTD input:  
Input range low limit value – 50°C (100°F) to Input range high limit value + 50°C (100°F)
- Range with a decimal point including the RTD input without a decimal point:  
–(Input span x 1%) °C (°F) to Input range high limit value + 50°C (100°F)

## DC input

Control range: [Scaling low limit value – Scaling span x 1%] to [Scaling high limit value + Scaling span x 10%]

## DC input disconnection

(Table 12.5-3)

DC input type	Value when DC input is disconnected
4 to 20mA DC, 1 to 5V DC	(Scaling low limit value – Scaling span x 1%) or less
0 to 1V DC	(Scaling high limit value + Scaling span x 10%) or more
0 to 20mA DC	PV corresponding to 0mA DC
0 to 5V DC, 0 to 10V DC	PV corresponding to 0V DC

## 12.6 Sensor correction

The PV is corrected when the temperatures in the controlled location differs from those of the sensor location.

This is effective within the input rated range regardless of the sensor correction value.

## 12.7 PV filter

Reduces the effect of noise by including a first order lag filter in the PV.

## 12.8 Power failure countermeasure

The setting data is backed up in the non-volatile IC memory.

## 12.9 Non-volatile memory data saving selection

If Non-volatile memory data [Unable to save] is selected during Non-volatile memory data saving selection, all setting values except for the input type selection can be changed temporarily. However, when the power to the unit is turned on again, those values revert to the values set before the Non-volatile memory data [Unable to save] was selected.

# 13. Specifications

## 13.1 Standard specifications

Rating

Rated scale

(Table 13.1-1)

Input		Scale range		Resolution
M	K	-200 to 1370 °C	-320 to 2500 °F	1°C(°F)
		-199.9 to 500.0°C	-199.9 to 932.0°F	0.1°C(°F)
	J	-200 to 1000 °C	-320 to 1800 °F	1°C(°F)
	R	0 to 1760 °C	0 to 3200 °F	1°C(°F)
	S	0 to 1760 °C	0 to 3200 °F	1°C(°F)
	B	0 to 1820 °C	0 to 3300 °F	1°C(°F)
	E	-200 to 800 °C	-320 to 1500 °F	1°C(°F)
	T	-199.9 to 400.0°C	-199.9 to 750.0°F	0.1°C(°F)
	N	-200 to 1300 °C	-320 to 2300 °F	1°C(°F)
	PL-II	0 to 1390 °C	0 to 2500 °F	1°C(°F)
	C(W/Re5-26)	0 to 2315 °C	0 to 4200 °F	1°C(°F)
	Pt100	-199.9 to 850.0°C	-199.9 to 999.9°F	0.1°C(°F)
		-200 to 850 °C	-300 to 1500 °F	1°C(°F)
	JPt100	-199.9 to 500.0°C	-199.9 to 900.0°F	0.1°C(°F)
		-200 to 500 °C	-300 to 900 °F	1°C(°F)

4 to 20mA	-1999 to 9999 (*)	1
0 to 20mA	-1999 to 9999 (*)	1
0 to 1V	-1999 to 9999	1
0 to 5V	-1999 to 9999	1
1 to 5V	-1999 to 9999	1
0 to 10V	-1999 to 9999	1

(\*) For DC current input, externally connect 50Ω shunt resistor (RES-S03-050, sold separately).

- Input** Thermocouple : K, J, R, S, B, E, T, N, PL-II, C (W/Re5-26)  
 External resistance, 100Ω or less  
 (However, for B input: 40Ω or less)
- RTD : Pt100, JPt100, 3-wire system  
 Allowable input lead wire resistance (10Ω or less per wire)
- DC current (mA): 0 to 20mA DC, 4 to 20mA DC  
 Input impedance: 50Ω  
 Connect 50Ω shunt resistor (RES-S03-050, sold separately) between input terminals.  
 Allowable input current: 50mA DC or less [when using the shunt resistor (sold separately)]
- DC voltage (V) : 0 to 1V DC  
 Input impedance (1MΩ or more)  
 Allowable input voltage (5V DC or less)  
 Allowable signal source resistance (2kΩ or less)
- : 0 to 5V DC, 1 to 5V DC, 0 to 10V DC  
 Input impedance (100kΩ or more)  
 Allowable input voltage (15V DC or less)  
 Allowable signal source resistance (100Ω or less)
- Supply voltage** : 24V DC  
 Allowable voltage fluctuation: 20 to 28V DC  
 Ripple voltage, 5%p-p or less

**General structure**

**External dimensions** : 17.5 x 75 x 85mm (W x H x D)

**Mounting method** : DIN rail mounting

**Applicable DIN rail specifications:** Top hat type rail TH35 JIS C 2812-1998

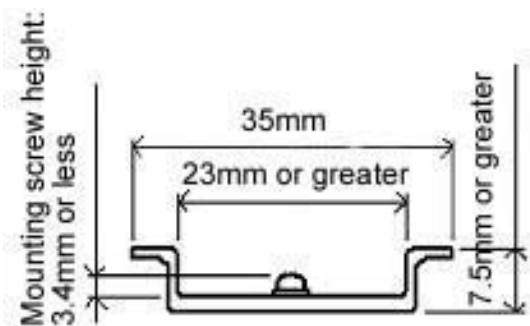

- Width : 35mm
- Height : 7.5mm or more
- Groove width : 23mm or more
- DIN rail mounting screw height: 3.4mm or less (at a DIN rail height of 7.5mm)

(Fig. 13.1-1)

- Case** : Flame resistant resin, Color: Light gray
- Base** : Flame resistant resin, Color: Light gray
- Bus plug, Spring type plug:** Polyamide resin, Color: Green

## Input performance

### Input accuracy

- Thermocouple : Within  $\pm 0.2\%$  of each input span  $\pm 1$  digit or within  $\pm 2^{\circ}\text{C}$  ( $4^{\circ}\text{F}$ ), whichever is greater  
However, for R, S input, 0 to  $200^{\circ}\text{C}$  (0 to  $400^{\circ}\text{F}$ ): Within  $\pm 6^{\circ}\text{C}$  ( $12^{\circ}\text{F}$ )  
B input, 0 to  $300^{\circ}\text{C}$  (0 to  $600^{\circ}\text{F}$ ): Accuracy is not guaranteed.  
K, J, E, T, N inputs, less than  $0^{\circ}\text{C}$  ( $32^{\circ}\text{F}$ ): Within  $\pm 0.4\%$  of input span  $\pm 1$  digit
- RTD : Within  $\pm 0.1\%$  of each input span  $\pm 1$  digit, or within  $\pm 1^{\circ}\text{C}$  ( $2^{\circ}\text{F}$ ), whichever is greater
- DC current and voltage: Within  $\pm 0.2\%$  of each input span  $\pm 1$  digit
- Input sampling period** : 0.25 seconds

## Control performance

### Control action

- PID action (with auto-tuning function)  
PI action: When derivative time is set to 0  
PD action (with manual reset function): When integral time is set to 0  
P action (with manual reset function): When integral and derivative times are set to 0  
ON/OFF action: When proportional band is set to 0  
OUT1 proportional band (P) : 0.0 to 110.0% (Default value: 2.5%)  
Integral time (I) : 0 to 1000s (Off when set to 0) (Default value: 200s)  
Derivative time (D) : 0 to 300s (Off when set to 0) (Default value: 50s)  
OUT1 proportional cycle : 1 to 120s [Default value: -R/M (30s), -S/M (3s) -C/M (3s), -A/M (Not available)]
- ARW : 0 to 100% (Default value: 50%)  
Manual reset :  $\pm$ Proportional band converted value (Default: 0.0)  
OUT1 ON/OFF hysteresis :  $0.1$  to  $100.0^{\circ}\text{C}$  ( $^{\circ}\text{F}$ ) (Default value:  $1.0^{\circ}\text{C}$ )  
DC input: 1 to 1000
- OUT1 high limit, OUT1 low limit: 0 to 100% (DC current output: -5 to 105%)  
(Not available for ON/OFF action)  
(Default: OUT1 low limit: 0%, OUT1 high limit: 100%)

### Control output (OUT1)

- Relay contact (-R/M) : 1a  
Control capacity, 3A 250V AC (resistive load)  
1A 250V AC (inductive load  $\cos\phi=0.4$ )  
Electrical life: 100,000 times
- Non-contact voltage (-S/M):  $12^{\pm 2}_0\text{V}$  DC (for SSR drive)  
Maximum 40mA DC (short circuit protected)
- DC current (-A/M) : 4 to 20mA DC  
Load resistance: Maximum  $550\Omega$   
Output accuracy: Within  $\pm 0.3\%$  of output span  
Resolution: 12000
- Open collector (-C/M) : 0.1A 24V DC (maximum), Isolation type

## Alarm

### Alarm 1 output

When Alarm 1 action is set as Energized, the alarm action point is set by  $\pm$  deviation from the SV (except Process value alarm).

When the input goes out of the range, the Event output turns ON or OFF (High/Low limit range alarm).

When the alarm action is set as Deenergized, the output acts conversely.

### Alarm type

One alarm can be selected from a choice of: High limit alarm, Low limit alarm, High/Low limits alarm, High/Low limit range alarm, Process high alarm, Process low alarm, High limit alarm with standby, Low limit alarm with standby, High/Low limits alarm with standby and No alarm action (10 types). (Default value: No alarm action) Alarm 1 output Energized or Deenergized can be selected as well.

Alarm 1 uses common output terminals with Loop break alarm, Heater burnout alarm/Actuator short circuit alarm (W, W3 option).

When Heating/Cooling control output (DC option) is applied, Event output becomes cooling output (OUT2). Therefore, Alarm 1, Loop break alarm and Heater burnout alarm/Actuator short circuit alarm cannot be outputted.

#### Setting range

High limit alarm	–(Scaling span) to Scaling span
Low limit alarm	–(Scaling span) to Scaling span
High/Low limits alarm	0 to Scaling span
High/Low limit range alarm	0 to Scaling span
Process high alarm	Scaling low limit to Scaling high limit value
Process low alarm	Scaling low limit to Scaling high limit value
High limit alarm with standby	–(Scaling span) to Scaling span
Low limit alarm with standby	–(Scaling span) to Scaling span
H/L limits alarm with standby	0 to Scaling span

Setting to 0 or 0.0 disables the alarm action (excluding Process high alarm, Process low alarm).

The negative minimum value is –199.9 or –1999, and the positive maximum value is 999.9 or 9999.

For High limit alarm, High/Low limits alarm and Process high alarm, Alarm 1 is activated in overscale, and the standby function of the alarms with standby is released.

For Low limit alarm, High/Low limits alarm and Process low alarm, Alarm 1 is activated in underscale, and the standby function of the alarms with standby is released.

**Setting value** : Initial value is zero (0).

**Setting accuracy**: The same as the input accuracy

**Action** : ON/OFF action

**Alarm hysteresis setting range**: 0.1 to 100.0°C (°F) (Default value: 1.0°C)  
DC input: 1 to 1000

**Output** : Open collector  
Control capacity, 0.1A 24V DC

## Alarm2, Alarm 3, Alarm 4

The alarm type and action are the same as those of Alarm 1.

However, There are no outputs to these alarms, and Alarm Energized/Deenergized action selection are not available.

Alarm status can be accessed by reading the status flag in serial communication.

## Loop break alarm

Detects actuator trouble (heater burnout, sensor burnout).

This alarm uses common output terminals with Alarm 1, Heater burnout alarm/ Actuator short circuit alarm (W, W3 option).

When Heating/Cooling control output (DC option) is added, the Event output becomes cooling output (OUT2). Therefore, Alarm 1, Loop break alarm and Heater burnout alarm/Actuator short circuit alarm cannot be outputted.

**Setting range** Loop break alarm time: 0 to 200 minutes (Default: 0 minutes)

Loop break alarm span: 0 to 150°C (°F) or 0.0 to 150.0°C (°F)

(Default: 0°C)

DC input: 0 to 1500

**Output** Open collector: Control capacity, 0.1A 24V DC

## Serial communication

Cable length : 1.2km (Maximum)  
Cable resistance: Within 50Ω (The terminator is not necessary or 120Ω or more on one side of the cable.)

Communication line : Based on EIA RS-485

Communication method : Half-duplex communication

Communication speed : 9600bps (4800, 9600, 19200bps)

Selectable by DIP switch

Synchronous system : Start-stop synchronous

Instrument number : Address 0 (0 to 95), Selectable by two Rotary switches

Communication protocol: Shinko protocol, Modbus ASCII, Modbus RTU

Selectable by DIP switch

The contents set by the DIP and Rotary switch will take effect when the power to the unit is turned on.

Therefore, settings changed after the power-on will not take effect.

Code form : ASCII, binary (\*)

Error detection : Parity check, Checksum (LRC), CRC (\*)

Error correction : Command request repeat system

Data format Start bit : 1

Data bit : 7, 8 (\*)

Parity : Even, Odd, No parity (\*)

Stop bit : 1

(\*): Automatically selected upon selecting the communication protocol.

**Insulation, Dielectric strength**  
**Circuit insulation configuration**

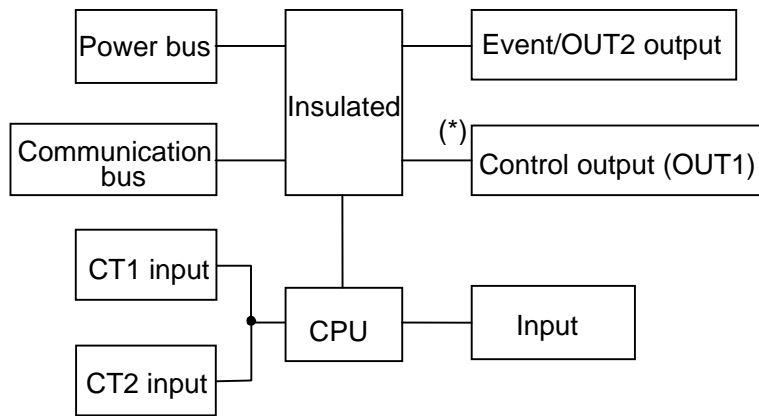

(\*) When the control output (OUT1) is non-contact voltage or DC current output, Control output (OUT1) is not insulated from Communication bus.

**Insulation resistance**

10M $\Omega$  or more, at 500V DC

**Dielectric strength**

For Non-contact voltage (-S/M), DC current (-A/M), Open collector output (-C/M)  
 Between input terminal and power terminal, 0.5kV AC for 1 minute  
 Between control output (OUT1) terminal and power terminal, 0.5kV AC for 1 minute  
 For Relay contact output (-R/M)  
 Between input terminal and power terminal, 0.5kV AC for 1 minute  
 Between control output (OUT1) terminal and power terminal, 1.5kV AC for 1 minute

**Others**

**Power consumption** : Approx. 2W

**Ambient temperature** : 0 to 50°C (32 to 122°F)

**Ambient humidity** : 35 to 85%RH (no condensation)

**Weight** : Approx. 85g

**Accessories** : Instruction manual 1 copy  
 For W (20A) option : Wire harness 3m 1 length  
 CT (CTL-6S) 1 piece  
 For W (100A) option : Wire harness 3m 1 length  
 CT (CTL-12-S36-10L1) 1 piece  
 For W3 (20A) option : Wire harness 3m 2 lengths  
 CT (CTL-6S) 2 pieces  
 For W3 (100A) option: Wire harness 3m 2 lengths  
 CT (CTL-12-S36-10L1) 2 pieces

**13.2 Optional specifications**

**Heater burnout alarm/Actuator short circuit alarm [Option code: W (single phase), W3 (3-phase)]**

This alarm cannot be applied to DC current output.

This alarm is also activated in overscale and underscale.

This alarm uses common output terminals with Alarm 1 and Loop break alarm.

When Heating/Cooling control output (DC option) is applied, Event output is used for a cooling output. Therefore, Alarm 1, Loop break alarm and Heater burnout alarm/Actuator short circuit alarm are not outputted.

Rating : 20A [W(20A), W3(20A),], 100A [W(100A), W3(100A)]  
 (Must be specified)

Setting range : 20A ; 0.0 to 20.0A (Off when set to 0.0)  
 100A ; 0.0 to 100.0A (Off when set to 0.0)

Setting accuracy: Within  $\pm 5\%$  of the rated value

Action point : Setting value  
 Action : ON/OFF action  
 Output : Open collector, Control capacity 0.1A 24V DC

Heater burnout alarm 1 (W, W3 option)  
 When control output is ON, and if CT1 input value (detected current) is lower than Heater burnout alarm 1 set value, this alarm is activated

If CT1 input value (detected current) is higher than Heater burnout alarm 1 set value, this alarm will not be activated.

Heater burnout alarm 2 (W3 option)

When control output is ON, and if CT2 input value (detected current) is lower than Heater burnout alarm 2 set value, this alarm is activated.

If CT2 input value (detected current) is higher than Heater burnout alarm 2 set value, this alarm will not be activated.

Actuator short circuit alarm 1 (W, W3 option)

When control output is OFF, and if CT1 input value (detected current) is higher than Heater burnout alarm 1 set value, this alarm is activated.

If CT1 input value (detected current) is lower than Heater burnout alarm 1 set value, this alarm will not be activated.

Actuator short circuit alarm 2 (W3 option)

When control output is OFF, and if CT2 input value (detected current) is higher than Heater burnout alarm 2 set value, this alarm is activated.

If CT2 input value (detected current) is lower than Heater burnout alarm 2 set value, this alarm will not be activated.

- Heater burnout alarm 1 (2)
- Actuator short circuit alarm 1 (2)

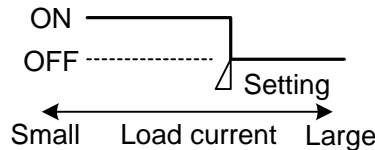

(Fig. 13.2-1)

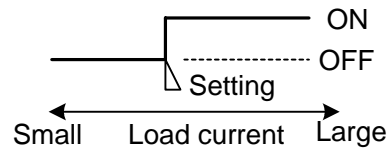

(Fig. 13.2-2)

- CT connection for the W3 option

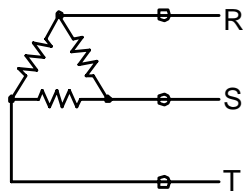

(Fig. 13.2-3)

Pass two wires out of R, S, T through the CT hole.

### Heating/Cooling control output (Option code: DC)

If this option is applied, Event output becomes cooling output (OUT2). Therefore, Alarm 1, Loop break alarm and Heater burnout alarm/Actuator short circuit alarm are not outputted.

OUT2 proportional band (P): 0.0 to 10.0 times OUT1 proportional band  
 (ON/OFF action when set to 0.0)

OUT2 integral time (I) : The same as that of OUT1.

OUT2 derivative time (D) : The same as that of OUT1.

OUT2 proportional cycle : 1 to 120 seconds (Default value: 3 seconds)

Overlap band/Dead band :  $-100.0$  to  $100.0^{\circ}\text{C}$  ( $^{\circ}\text{F}$ ) (Default value:  $0.0^{\circ}\text{C}$ )  
 DC input:  $-1000$  to  $1000$  (The placement of the decimal point follows the selection)

OUT2 ON/OFF action hysteresis setting: 0.1 to 100.0°C (°F) (Default value: 1.0°C)  
 DC input: 1 to 1000  
 OUT2 high limit, OUT2 low limit: 0 to 100% (Not available for ON/OFF action)  
 (Default value: OUT2 low limit: 0%, OUT2 high limit: 100%)  
 OUT2 action mode selection:  
 Air cooling (Linear characteristic) (Default value)  
 Oil cooling (1.5th power of the linear characteristic)  
 Water cooling (2nd power of the linear characteristic)

## 14. Troubleshooting

If any malfunction occurs, refer to the following items after checking the power supply to the master and the slave (NCL-13A).

### 14.1 Communication

Problem	Presumed cause and solution
Communication failure	<ul style="list-style-type: none"> <li>• The connection or wiring of communication is not secure.</li> <li>• Burnout on the communication cable or imperfect contact with the connector.</li> <li>• Communication speed of the slave does not coincide with that of the master.</li> <li>• The data bit, parity and stop bit of the master do not accord with those of the slave.</li> <li>• The instrument number (address) of the slave does not coincide with that of the command</li> <li>• The instrument number (address) of the slave is duplicated in multiple slaves</li> </ul>
Though it is able to communicate, the response is "NAK".	<ul style="list-style-type: none"> <li>• Check whether a non-existent command code has been sent.</li> <li>• The setting command data goes outside the setting range of the slave.</li> <li>• The unit cannot be set when functions such as AT is performing.</li> </ul>

### 14.2 Control

Problem	Presumed cause and solution
PV (Process variable) does not rise.	<ul style="list-style-type: none"> <li>• The sensor is out of order. Replace the sensors.</li> <li>• Sensor is not securely connected to the instrument input terminals, or actuator is not securely connected to the instrument output terminal.</li> <li>• Ensure that the wiring of sensor terminals or actuator terminals are correct.</li> </ul>
The control output remains in an ON status.	<ul style="list-style-type: none"> <li>• OUT1 (OUT2) low limit value is set to 100% or higher. Set it to a suitable value.</li> </ul>
The control output remains in an OFF status.	<ul style="list-style-type: none"> <li>• OUT1 (OUT2) high limit value is set to 0% or less. Set it to a suitable value.</li> </ul>

### 14.3 PV

Problem	Presumed cause and solution
PV is high.	<ul style="list-style-type: none"> <li>• Thermocouple, RTD or DC voltage (0 to 1V DC) is burnt out. Change each sensor.</li> </ul> <p><b>How to check whether the sensor is burnt out</b></p> <p>[Thermocouple] If the input terminal of the instrument is shorted and if a value around room temperature is indicated, the instrument is likely to be operating normally, however, the sensor may be burnt out.</p> <p>[RTD] If approximate 100Ω of resistance is connected to the input terminals between A-B of the instrument and between B-B is shorted, and if approximate 0°C (32°F) is indicated, the instrument is likely to be operating normally, however, the sensor may be burnt out.</p> <p>[DC voltage (0 to 1V DC)] If the input terminal of the instrument is shorted and if a scaling low limit value is indicated, the instrument is likely to be operating normally, however, the signal wire may be disconnected.</p> <ul style="list-style-type: none"> <li>• Check whether the input signal wires of thermocouple, RTD or DC voltage (0 to 1V DC) are securely connected to the instrument input terminals. Ensure that the sensor terminals are connected to the instrument input terminals securely.</li> </ul>
PV is low.	<ul style="list-style-type: none"> <li>• Check whether the input signal source for DC voltage (1 to 5V DC) or DC current (4 to 20mA DC) is disconnected.</li> </ul> <p><b>How to check whether the input signal wire is disconnected</b></p> <p>[DC voltage (1 to 5V DC)] If the input to the input terminals of the instrument is 1V DC and if a scaling low limit value is indicated, the instrument is likely to be operating normally, however, the signal wire may be disconnected.</p> <p>[DC current (4 to 20mA DC)] If the input to the input terminals of the instrument is 4mA DC and if a scaling low limit value is indicated, the instrument is likely to be operating normally, however, the signal wire may be disconnected.</p> <ul style="list-style-type: none"> <li>• Check whether the input signal wire for DC voltage (1 to 5V DC) or DC current (4 to 20mA DC) is securely connected to the instrument input terminals.</li> <li>• Check whether the polarity of thermocouple or compensating lead wire is correct. Check whether codes (A, B, B) of the RTD agree with the instrument terminals. Ensure that they are wired properly.</li> </ul>
The indication of PV display is abnormal or unstable.	<ul style="list-style-type: none"> <li>• The sensor input or temperature unit (°C or °F) setting is improper. Set the sensor input and the temperature unit properly.</li> <li>• Sensor correcting value is unsuitable. Set it to a suitable value.</li> </ul>

The indication of PV display is abnormal or unstable.	<ul style="list-style-type: none"><li>• AC may be leaking into the sensor circuit. Change the sensor for the ungrounded type.</li><li>• There may be equipment that interferes with or makes noise near the control unit. Keep equipment that interferes with or makes noise away from the control unit.</li></ul>
---	--

For further inquiries, please consult our agency or the shop where you purchased the unit.

**SHINKO TECHNOS CO.,LTD.  
OVERSEAS DIVISION**

Reg. Office : 1-2-48, Ina, Minoo, Osaka, Japan

Mail Address : P.O.Box 17, Minoo, Osaka, Japan

URL : <http://www.shinko-technos.co.jp>

E-mail : [overseas@shinko-technos.co.jp](mailto:overseas@shinko-technos.co.jp)

Tel : 81-72-721-2781

Fax: 81-72-724-1760

No.NCL11E2 2005.03